



Designation: ~~D6773-02~~ Designation: D 6773 – 08

Standard Test Method for Bulk Solids Using the Schulze Ring Shear Tester¹

This standard is issued under the fixed designation D 6773; the number immediately following the designation indicates the year of original adoption or, in the case of revision, the year of last revision. A number in parentheses indicates the year of last reapproval. A superscript epsilon (ϵ) indicates an editorial change since the last revision or reapproval.

1. Scope*

1.1 This test method covers the apparatus and procedures for measuring the unconfined yield strength of bulk solids during both continuous flow and after storage at rest. In addition, measurements of internal friction, bulk density, and wall friction on various wall surfaces are included. ~~The SI system of units has been used throughout.~~

1.2 The most common use of this information is in the design of storage bins and hoppers to prevent flow stoppages due to arching and ratholing, including the slope and smoothness of hopper walls to provide mass flow. Parameters for structural design of such equipment may also be derived from this data. Another application is the measurement of the flowability of bulk solids, for example, for comparison of different products or optimization.

~~1.3~~

1.3 All observed and calculated values shall conform to the guidelines for significant digits and rounding established in Practice D 6026.

1.3.1 The procedures used to specify how data are collected/recorded or calculated in this standard are regarded as the industry standard. In addition, they are representative of the significant digits that generally should be retained. The procedures used do not consider material variation, purpose for obtaining the data, special purpose studies, or any considerations for the user's objectives; and it is common practice to increase or reduce significant digits of reported data to be commensurate with these considerations. It is beyond the scope of this standard to consider significant digits used in analysis methods for engineering design.

1.4 The values stated in SI units are to be regarded as standard. No other units of measurement are included in this standard.

1.5 This standard does not purport to address all of the safety concerns, if any, associated with its use. It is the responsibility of the user of this standard to establish appropriate safety and health practices and determine the applicability of regulatory limitations prior to use.

2. Referenced Documents

2.1 *ASTM Standards:*²

D 653 Terminology Relating to Soil, Rock, and Contained Fluids

D 3740 Practice for Minimum Requirements for Agencies Engaged in Testing and/or Inspection of Soil and Rock as Used in Engineering Design and Construction

D 6026 Practice for Using Significant Digits in Geotechnical Data

~~D 6128 Standard Test Method for Shear Testing Method for~~ Bulk Solids Using the Jenike Shear Cell

3. Terminology

~~3.1 Definitions of terms used in this test method are in accordance with Terminology D 653~~

3.1 For common definitions of terms in this standard, refer to Terminology D 653.

3.2 Definitions of Terms Specific to This Standard:

3.2.1 *adhesion test, n*—a static wall friction test with time consolidation.

~~3.3 *angle of internal friction, ϕ*~~

3.2.2 *angle of internal friction, φ , n*—the angle between the axis of normal stress (abscissa) and the tangent to the yield locus.

~~3.4~~

3.2.3 *angle of wall friction, ϕ' , n*—the arctan of the ratio of the wall shear stress to the wall normal stress.

~~3.5~~

3.2.4 *bin, n*—a container or vessel for holding a bulk solid, frequently consisting of a vertical cylinder with a converging hopper.

¹ This test method is under the jurisdiction of ASTM Committee D18 on Soil and Rock and is the direct responsibility of Subcommittee D18.24 on Characterization and Handling of Powders and Bulk Solids.

Current edition approved March 10, 2002. Published April 2002.

Current edition approved Oct. 1, 2008. Published November 2008. Originally approved in 2002. Last previous edition approved in 2002 as D 6773 – 02.

² For referenced ASTM standards, visit the ASTM website, www.astm.org, or contact ASTM Customer Service at service@astm.org. For *Annual Book of ASTM Standards* Vol 04.08, volume information, refer to the standard's Document Summary page on the ASTM website.

*A Summary of Changes section appears at the end of this standard.

Sometimes referred to as silo, bunker or elevator.

3.6

3.2.5 bulk density, ρ_b , n —the mass of a quantity of a bulk solid divided by its total volume.

3.7

3.2.6 bulk solid, n —an assembly of solid particles handled in sufficient quantities that its characteristics can be described by the properties of the mass of particles rather than the characteristics of each individual particle. It may also be referred to as a granular material, particulate solid, or powder. Examples are sugar, flour, and ore.

3.8

3.2.7 bunker, n —synonym for *bin*, but sometimes understood as being a bin without any or only a small vertical part at the top of the hopper.

3.9

3.2.8 consolidation, n —the process of increasing the unconfined yield strength of a bulk solid.

3.10—the process of decreasing the porosity of a bulk solid, which usually results in increasing its unconfined yield strength.

3.2.9 critical state, n —a state of stress in which the bulk density of a bulk solid and the shear stress in the shear zone remain constant during shear under constant normal stress.

3.11

3.2.10 effective angle of friction, δ , n —the inclination of the effective yield locus (EYL).

3.12

3.2.11 effective yield locus (EYL), n —straight line passing through the origin of the σ , τ -plane and tangential to the steady state Mohr circle, corresponding to steady state flow conditions of a bulk solid of given bulk density.

3.13

3.2.12 elevator, n —synonym for *bin*. Commonly used in the grain industry.

3.14

3.2.13 failure (of a bulk solid), n —plastic deformation of an overconsolidated bulk solid subject to shear, causing dilation and a decrease in strength.

3.15

3.2.14 flow, steady state, n —continuous plastic deformation of a bulk solid at critical state.

3.16

3.2.15 flow function, FF , n —the plot of unconfined yield strength versus major consolidation stress for one specific bulk solid.

3.17

3.2.16 granular material, n —synonym for *bulk solid*.

3.18

3.2.17 hopper, n —the converging portion of a bin.

3.19

3.2.18 major consolidation stress, σ_1 , n —the major principal stress given by the Mohr stress circle of steady state flow. This Mohr stress circle is tangential to the effective yield locus.

3.20

3.2.19 Mohr stress circle, n —the graphical representation of a state of stress in coordinates of normal and shear stress, that is, in the σ , τ -plane.

3.21

3.2.20 normal stress, σ , n —the stress acting normally to the considered plane.

3.22

3.2.21 particulate solid, n —synonym for *bulk solid*.

3.23

3.2.22 powder, n —synonym for *bulk solid*, particularly when the particles of the bulk solid are fine.

3.24

3.2.23 silo, n —synonym for *bin*.

3.25

3.2.24 shear test, n —an experiment to determine the flow properties of a bulk solid by applying different states of stress and strain to it.

3.26

3.2.25 shear tester, n —an apparatus for performing shear tests.

3.273.2.26 time angle of internal friction, ϕ_{ϕ} , n —inclination of the time yield locus of the tangency point with the Mohr stress circle passing through the origin.

3.28

3.2.27 time yield locus, n —the yield locus of a bulk solid which has remained at rest for a certain time under a given normal stress for a certain time.

3.29

3.2.28 *unconfined yield strength, f_c , n* —the major principal stress of the Mohr stress circle being tangential to the yield locus with the minor principal stress being zero.

3-30

3.2.29 *wall normal stress, σ_w , n* —the normal stress present at a confining wall.

3-31

3.2.30 *wall shear stress, τ_w , n* —the shear stress present at a confining wall.

3-32

3.2.31 *wall yield locus, n* —a plot of the wall shear stress versus wall normal stress. The angle of wall friction is obtained from the wall yield locus as the arctan of the ratio of the wall shear stress to wall normal stress.

3-33

3.2.32 *yield locus, n* —plot of shear stress versus normal stress at failure. The yield locus (YL) is sometimes called the instantaneous yield locus to differentiate it from the time yield locus.

4. Summary of Test Method

4.1 A representative sample/specimen of bulk solid is placed in a shear cell of specific dimensions.

4.2 When running an instantaneous or time shear test, a normal load is applied to the cover, and the specimen is presheared until a steady state shear value has been reached. The shear stress is then immediately reduced to zero.

4.3 An instantaneous test is run by shearing the specimen under a reduced normal load until the shear force goes through a maximum value and then begins to decrease.

4.4 A time shear test is run similarly to an instantaneous shear test, except that the specimen is placed in a consolidation bench for the specified time between the preshear and shear steps.

4.5 A wall friction test is run by sliding the specimen over a coupon of wall material and measuring the frictional resistance as a function of normal, compressive load.

4.6 A wall friction time test involves sliding the specimen over the coupon of wall material, stopping and leaving the load on the specimen for a predetermined period, and then sliding it again to see if the shearing force has changed.

5. Significance and Use

5.1 Reliable, controlled flow of bulk solids from bins and hoppers is essential in almost every industrial facility. Unfortunately, flow stoppages due to arching and ratholing are common. Additional problems include uncontrolled flow (flooding) of powders, segregation of particle mixtures, useable capacity which is significantly less than design capacity, caking and spoilage of bulk solids in stagnant zones, and structural failures.

5.2 By measuring the flow properties of bulk solids, and designing bins and hoppers based on these flow properties, most flow problems can be prevented or eliminated (1).³

5.3 For bulk solids with a significant percentage of particles (typically, one third or more) finer than about 6 mm (¼ in.), the unconfined yield strength is governed by the fines (–6 mm fraction). For such bulk solids, strength and wall friction tests may be performed on the fine fraction only.

5.4 This test method covers operation of the manually-controlled Schulze Ring Shear Tester. An automated version of this tester is also available. Its method of testing bulk solids is similar in principle to that described in this test method.

NOTE 1—The quality of the result produced by this standard is dependent on the competence of personnel performing it, and the suitability of the equipment and facilities used. Agencies that meet the criteria of Practice D 3740 are generally considered capable of competent and objective testing/sampling/inspection/etc. Users of this standard are cautioned that compliance with Practice D 3740 does not in itself assure reliable results. Reliable results depend on many factors; Practice D 3740 provides a means of evaluating some of those factors. Practice D 3740 was developed for agencies engaged in the testing or inspection (or both) of soil and rock. As such it is not totally applicable to agencies performing this standard. However, users of this standard should recognize that the framework of Practice D 3740 is appropriate for evaluating the quality of an agency performing this standard. Currently there is no known qualifying national authority that inspects agencies that perform this standard.

6. Apparatus

6.1 The Schulze Ring Shear Tester (Figs. 1-6) is composed of a base 1 and a casing 2. The casing 2 contains the driving and measuring units and carries the working table 38.

6.2 The driving axle 5 (with detachable plastic cap 6) causes the shear cell 4 to rotate. The driver pins at the underside of the shear cell must set in the toothed wheel at the driving axle 5 to ensure a close connection between shear cell and driving axle. The driving axle is driven by an electric motor and can rotate to the right or to the left. In order to shear the bulk solid sample/specimen, the driving axle 5 along with the shear cell 4 rotate clockwise (as seen from the top). The electric motor is controlled from the front panel 35 at the front side of casing 2 (Fig. 3). The motor and drive system cause the shear cell to rotate at a speed adjustable between 0.007 and 0.13 rad/min.

³ Annual Book of ASTM Standards, Vol 04.09.

³ The boldface numbers in parentheses refer to the list of references at the end of this standard.

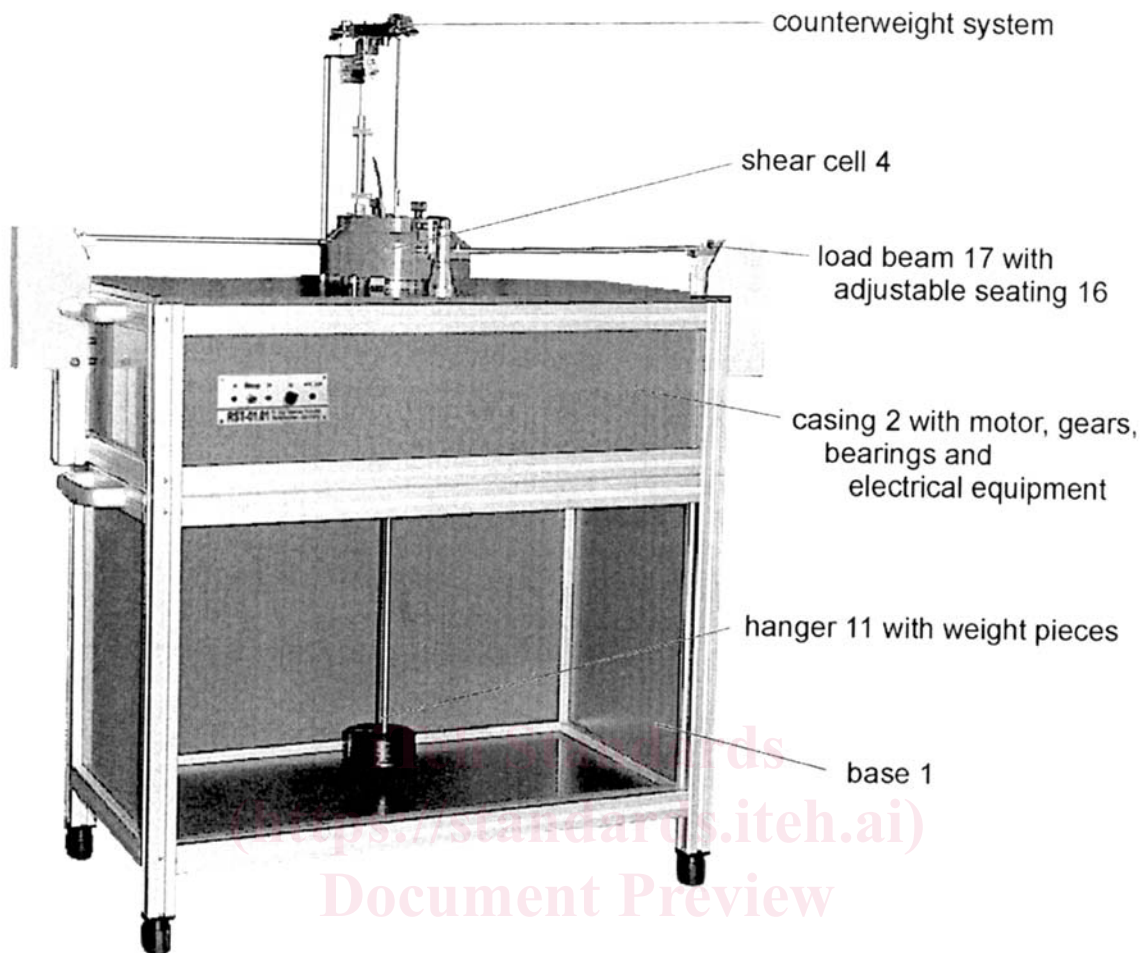

FIG. 1 Ring Shear Tester (Overall View)

6.3 The shear cell lid 7 as well as the bottom of the shear cell 4 has bent bars made of stainless steel (Fig. 4) to prevent slipping of the bulk solid at the lid or the bottom of the shear cell.

NOTE 1—The 2—The standard cell has 20 bars, each of which is 4 mm tall ($h_{Mi} = 4$ mm, Fig. 8).

6.4 The crossbeam 8 sits on the lid 7 and is fixed with two knurled screws 9. The crossbeam 8 has several functions: In the center of the crossbeam 8 is a fixed axis 10 with a hook to append the hanger 11 (in Figs. 3 and 4 only the handle of the hanger standing out from the driving axle can be seen). Rollers at the ends of the crossbeam and the removable guide rollers 12 prevent movement of lid 7 from the centered position.

6.5 A hook 14 at the upper end of the axis 10 of the crossbeam 8 is fastened to the balance arm 15. This arm along with counterweight counterbalance 29 (Fig. 6) serves to compensate for the weights masses of lid 7, crossbeam 8, hanger 11, and tie rods 13. The counterweight counterbalance 29 is found at the rear side of the balance arm 15. The movable counterweight counterbalance 29 is shifted along the balance arm to adjust the counterweight force. force caused by the counterbalance mass. The fixation screw 18 (knurled screw) fixes the counterweight counterbalance 29 on the balance arm. For more precise adjustment of the counterweight force, force caused by the counterbalance mass, the balance arm 15 is provided additionally with a smaller movable weight mass 30. After unscrewing the knurled screw, which is the major part of the movable weight mass 30, the movable weight mass 30 can be shifted along the balance arm. When the counterbalance weight mass is well adjusted, the lid, crossbeam, tie rods, and hanger do not press on the bulk solid sample; solid; that is, the vertical stress at the surface of the bulk solid sample is equal to zero.

6.6 A digital displacement indicator 31 (Fig. 7) is used for the measurement of the height of the bulk solid sample specimen.

6.7 Bolts at the ends of the crossbeam 8 are used to append the tie rods 13. Therefore, a circular hole is at one end of each tie rod 13. The opposite end is provided with an elongated hole for suspending in the adjustable seating 16 attached to the load beam 17. The seatings 16 are adjustable to enable the adjustment alignment of the horizontal position of the lid 7.

6.8 The rotation of the lid 7 is prevented by the tie rods 13 which transfer the tensile force to the load beams 17.

6.9 The bottom part of the hanger 11, which hangs on the crossbeam 8 and serves for exerting a normal load N on the bulk solid sample, solid, is located within the base 1 (Fig. 1). The hanger has a circular plate 19 at its lower end for holding the weight applied mass pieces.

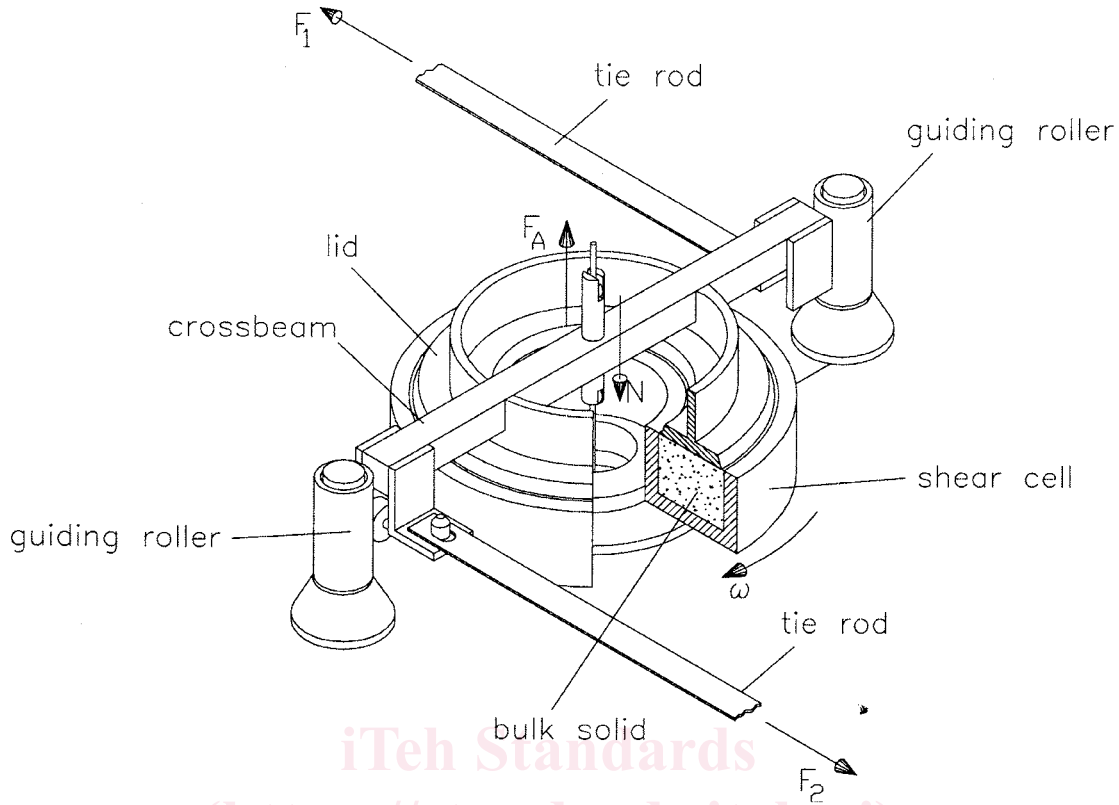

FIG. 2 Shear Cell (in Principle)

6.10 The base 1 has four adjustable stands 3 (Fig. 5), with which the Ring Shear Tester is to be adjusted accurately in a horizontal position to level the Ring Shear Tester.

6.11 For control of the motor drive a front panel 35 (Fig. 3) is at the front side of the casing 2.

6.12 The load beams 17 are connected parallel. Each load beam should be capable of measuring a force up to 200 N with a precision of 0.02 % of full scale. Thus, the total measuring range, which is twice the measuring range of one load beam, is 400 N. The signal from the force transducer is conditioned by an amplifier and shown on a recorder. **Note 2—Danger! Warning:** To avoid overloading of the load beams, the indicated maximum normal load must not be exceeded!

6.13 For the Schulze Ring Shear Tester RST-01.01 different shear cells are available. The dimensions of the Standard cell and a smaller cell can be taken from Table 2 and Fig. 8. For special purposes (for example, reduced internal volume) other dimensions are also available.

6.14 The time consolidation bench serves for the storage of shear cells with bulk solid samples under load. For special purposes (for example, reduced internal volume) other dimensions are also available. The following table provides a rough indication of the applicability of various cell sizes based on maximum particle size of the bulk solid (monodisperse = narrow particle size distribution, for example, plastics pellets, grain). Values in parentheses are valid if particles are not brittle.

Shear cell type	maximum particle size, x_{max}	
	monodisperse	broad distribution, 0 ... x_{max}
M	5 mm	10 mm
S	2.5 mm	5 mm
MV10	1 (1.5) mm	2 (3) mm
SV10	0.75 (1) mm	1.5 (2) mm

6.14 The time consolidation bench serves for the storage of shear cells with bulk solid specimens under load.

6.14.1 The time consolidation bench (Fig. 9) is composed of a frame Z1, on which are fastened three supporting plates Z2. One small shear cell (type S, volume approx. 200 cm³) can be placed on each plate. The shape of the plate Z2 centers the shear cell.

6.14.2 Through the central depression of the time consolidation crossbeam 26 the normal load is exerted during time consolidation as shown in the left part of Fig. 9. The lower end of the loading rod Z4 is equipped with a central tip.

6.14.3 The transparent cylindrical plastic cap Z3, when pressed on plate Z2, protects the samples/specimens from the surrounding atmosphere (for example, to reduce changes of the moisture (water) of the bulk solid samples/specimens). This cap Z3 is joined to the loading rod Z4 through a rubber bellows Z8.

6.14.4 At the upper end of the loading rod Z4 a disk Z5 is fastened for supporting weight/applied mass pieces by which the vertical load for time consolidation is applied.

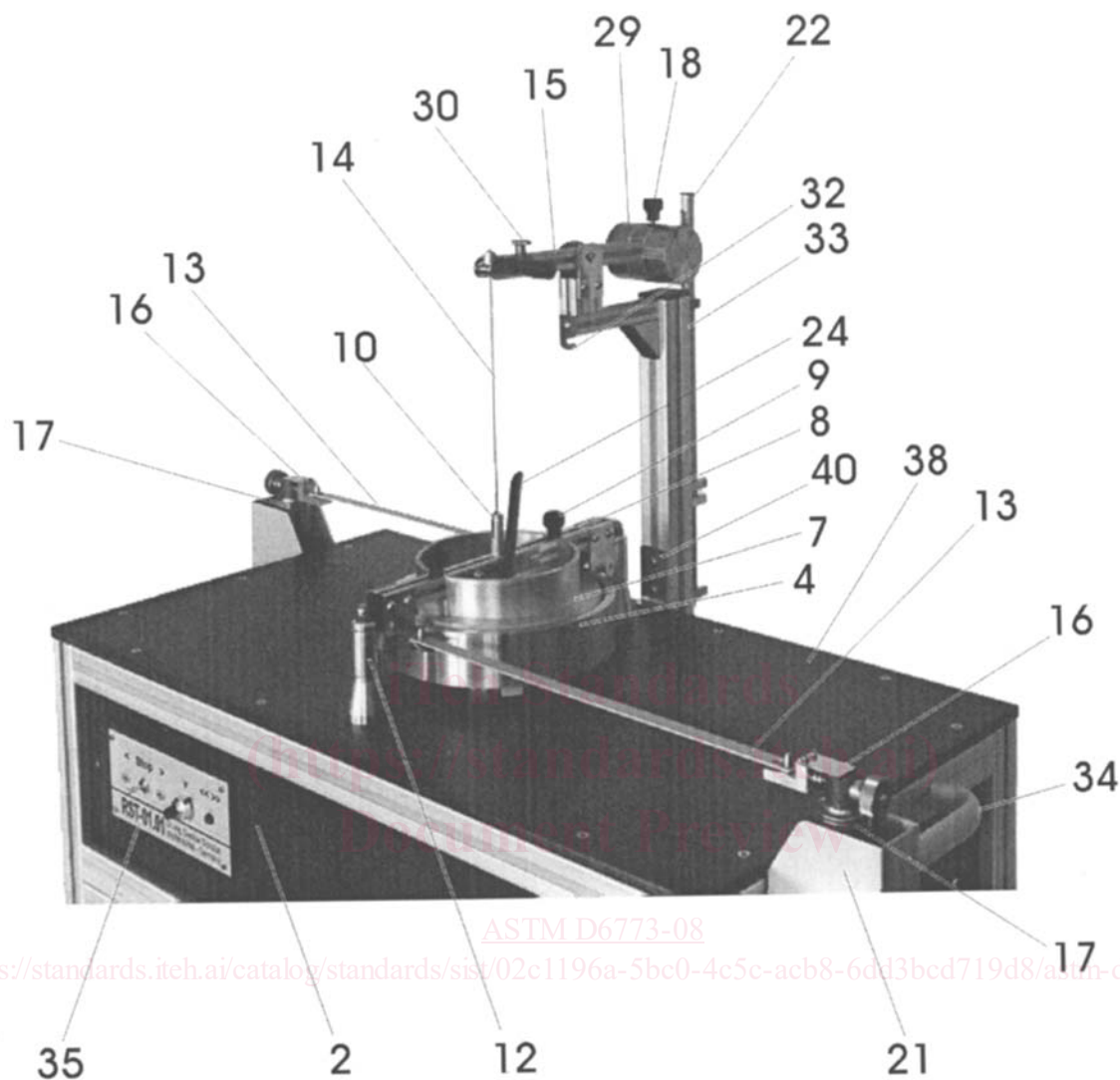

FIG. 3 Ring Shear Tester (Upper Part)

6.14.5 The fixing screw Z6 serves for the fixation of the loading rod Z4 in the upper position (Fig. 9, on the right). For moving the loading rod upwards or downwards, the fixing screw must be unscrewed somewhat. In the loading position (Fig. 9, on the left) the fixing screw must remain unscrewed.

6.14.6 For horizontal alignment, the time consolidation bench is provided with four adjustable feet Z7.

6.15 The wall friction cells allow the measurement of wall yield loci from which wall friction angles can be calculated.

6.15.1 The bottom ring 48 of the wall friction cell (see Fig. 10) contains the wall material sample to be tested. The wall material coupon is placed on an appropriate number of spacer rings 51. The thickness of each spacer ring is 2 mm. The wall material coupon is placed on an appropriate number of spacer rings 51 to form an initial powder bed height of 8 to 10 mm. The thickness of each spacer ring is 2 mm.

6.15.2 To prevent any relative circumferential displacement between the bottom ring 48 and the wall material coupon, four driving pins 50 are installed at the outer wall of the bottom ring 48. The annular wall material coupon has to be provided with notches for these driving pins so that bottom ring and wall material coupon are interlocked. The required dimensions of the wall material coupon are shown in Fig. 11.

6.15.3 The lid 49 (Fig. 12) has bent bars from stainless steel to prevent slipping of the bulk solid at the lid of the shear cell. Additionally, the lid of a wall friction cell is provided with downwards protruding edges at the inner and outer radius.

6.15.4 The dimensions of the wall shear cell are shown in Table 1 and Fig. 13.

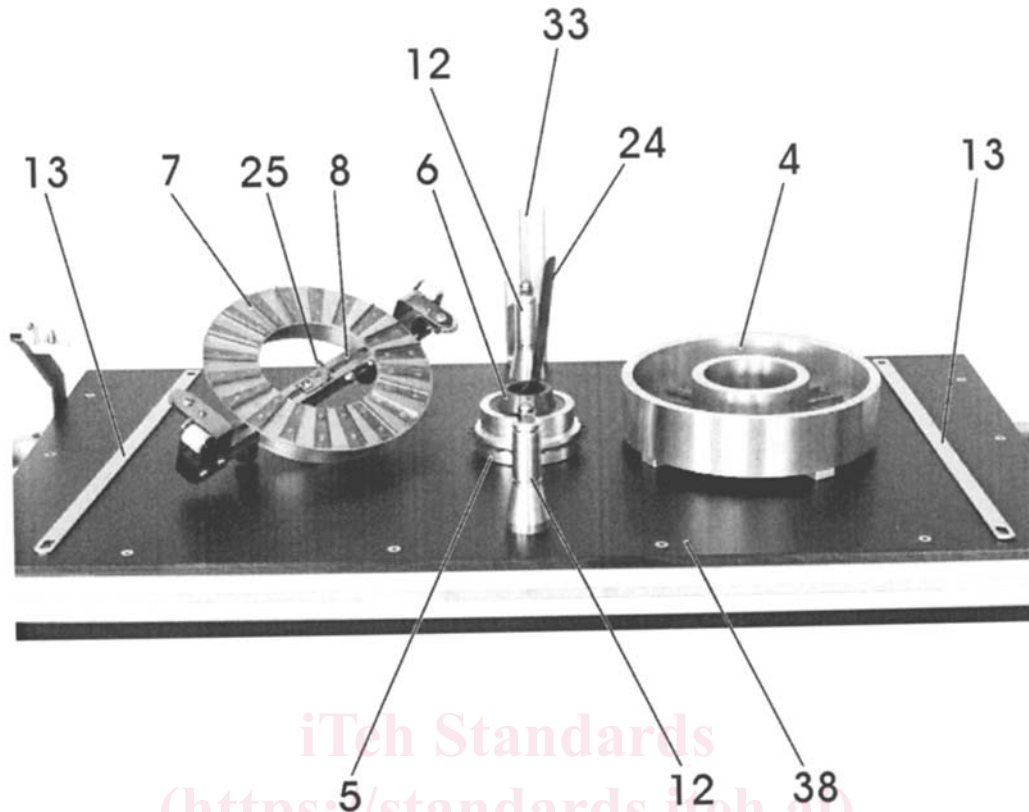

FIG. 4 Upper Part of the Ring Shear Tester, Shear Cell Removed

6.16 A spatula having a rigid, sharp, straight blade at least 50 % longer than the width of the annulus of the shear cell, and at least 20 mm wide, is needed.

6.17 A laboratory balance having a maximum capacity of at least 50 N with a precision of 0.01 % or better is required.

6.18 The laboratory balance used for powder testing should be free of vibrations caused by traffic or heavy machinery. Ideally, the room should be temperature and humidity controlled, or, if this is not possible, it should be maintained at nearly constant ambient conditions. Direct sunlight, especially on the time consolidation bench, is to be avoided.

NOTE 3—Temperature- and humidity-sensitive materials may need to be tested at different temperatures and moisture (water) contents, because this often happens in industrial environments. The laboratory environment must approximate production for meaningful testing.

7. Specimen Preparation

7.1 Filling the Cell (Fig. 14):

7.1.1 Fill the shear cell 4 uniformly in small horizontal layers by a spoon or spatula without applying force to the surface of the material until the material cell is somewhat over the top of the cell wall, slightly overfilled with material. The filling should be conducted in such a way as to ensure make sure that there are no voids within the cell.

7.1.2 Remove excess material in small quantities by scraping off with a blade 1 until flush with the top of the annulus. At first the blade should be scraped counterclockwise across the ring one or two times in a zigzag motion. Then the blade should be scraped around the annulus counterclockwise, as shown in Fig. 14a, whereby the blade should be inclined by an angle $\alpha = 15$ to 30° to the radial direction. The blade should always be held vertically or tilted by a few degrees to the vertical (angle $\beta = 0^\circ$ to 10°) as shown in Fig. 14b. Do not exert a downward force on the material with the blade.

NOTE 4—If coarse particles are present, scraping may tear them from the surface and alter the structure. In such cases it is better to attempt to fill the cell so that the material surface is flush with the annulus after filling.

8. Procedure

8.1 Shear Testing Procedure

8.1.1 Synopsis:

8.1.1.1 A point of a yield locus is measured in two steps: At first, a bulk solid sample specimen is consolidated (preshear) with a selected weight mass m_{wp} to develop a shear zone in which steady state flow occurs. Then the strength of the consolidated sample specimen is measured (shear).

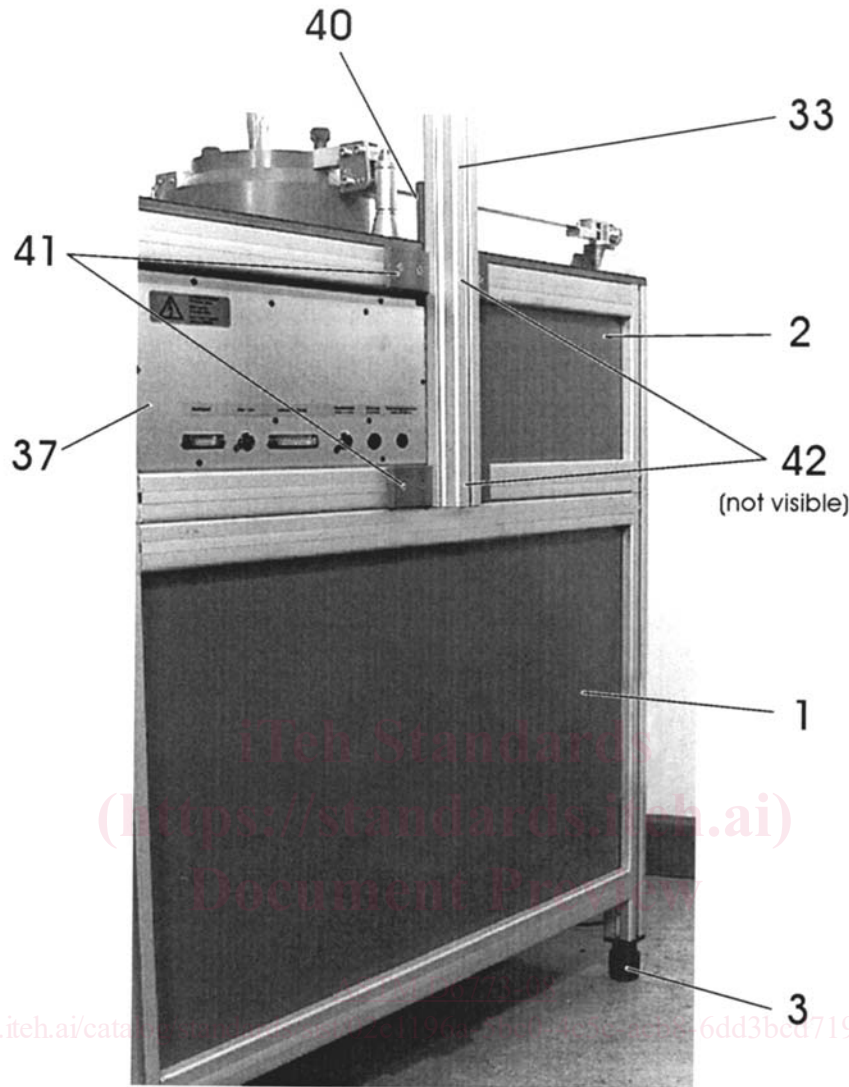

FIG. 5 View on the Reverse Side of the Ring Shear Tester

8.1.1.2 The time consolidation is measured using a similar procedure as for the Jenike Shear Tester (see Standard D 6128).

8.1.2 Preshear:

8.1.2.1 If necessary, clean the outside of the shear cell. Then weigh determine the mass of the shear cell with contents. Note the total mass $m_{s,tot}$.

~~8.1.2.2 Ascertain that the power supply is turned on.~~

8.1.2.2 Ascertain that the power supply has been turned on at least 15 min to ensure that the unit is properly warmed up.

8.1.2.3 Put the filled shear cell 4 on the driving axle 5 (Fig. 15). ~~Ensure~~ Make sure that the driver pins on the underside of the shear cell engage the toothed wheel of the driving axle 5.

8.1.2.4 Select the first preshear normal stress $\sigma_{p,1}$ on the basis of the bulk density of the test material, in accordance with the following table:

ρ_b (kg/m ³)	$\sigma_{p,1}$ (kPa)
< 300	approximately 1.5
300 to 800	approximately 2.0
800 to 1600	approximately 2.5
1600 to 2400	approximately 3.0
> 2400	approximately 4.0

NOTE 5—Follow 8.1.2.5-8.1.2.9 only if the normal load at preshear is greater than 15 N. Otherwise go to 8.1.2.10—. The latter procedure is necessary so as to not over-consolidate a bulk solid specimen at small normal loads.

8.1.2.5 Connect crossbeam 8 and lid 7 using the knurled screws 9. Fasten screws only very slightly. Position the lid concentrically on the shear cell and turned a few degrees counterclockwise to its shear position (shear position: longitudinal axis

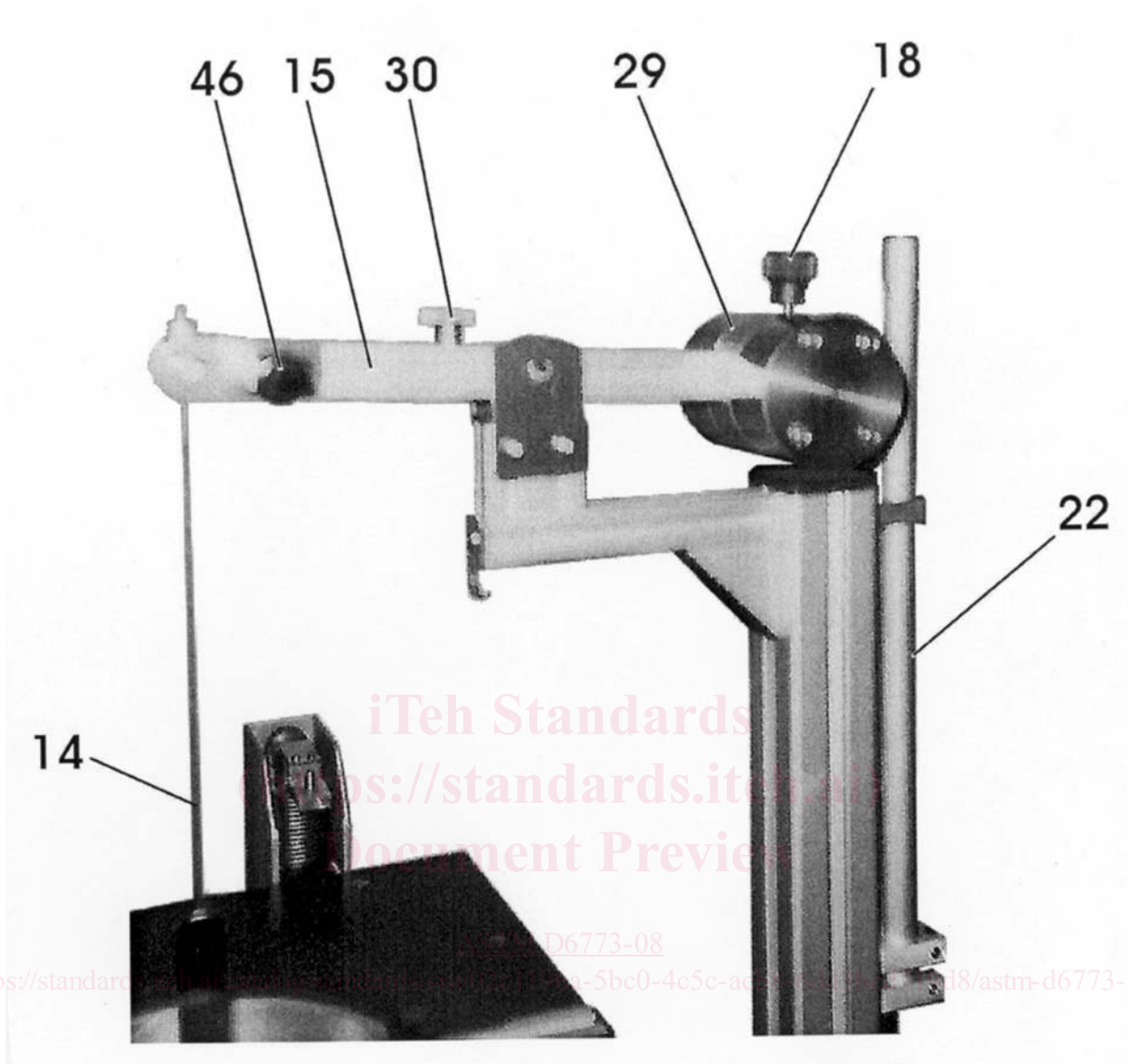

FIG. 6 Counterweight System

TABLE 1 Wall Shear Cell Dimensions

	Standard Wall Friction Cell, Type WM
Cross-section (lid) A_D	226 cm ²
r_{ID}	51 mm
r_{aD}	99 mm
r_{iSZ}	42.5 mm
r_{aSZ}	107.5 mm
h_{SZ}	24 mm
h_{Mit}	4 mm
Material	Aluminum

of the crossbeam is perpendicular to the front edge of the casing 2). The open side of hook 25 in the center of crossbeam 8 should be directed to the right. Locate handle 24 of hanger 11 on the right side of crossbeam 8 (Fig. 16).

8.1.2.6 Put tie rods 13 on both the bolts at the ends of crossbeam 8 (circular holes of tie rods 13) and seatings 16 at load beams 17 (long hole of the tie rod 13).

NOTE 6—The tie rods 13 should have some clearance in the seatings 16; that is, the tie rods must not be stressed at this stage. Important: If it is not possible to connect the tie rods as described above, do not move the lid manually since this would influence the test result. Only use the motor drive to turn the shear cell with the lid in a position where it is possible to connect the tie rods to the load beams.

8.1.2.7 Append hanger 11 at hook 25 at the lower side of crossbeam 8.

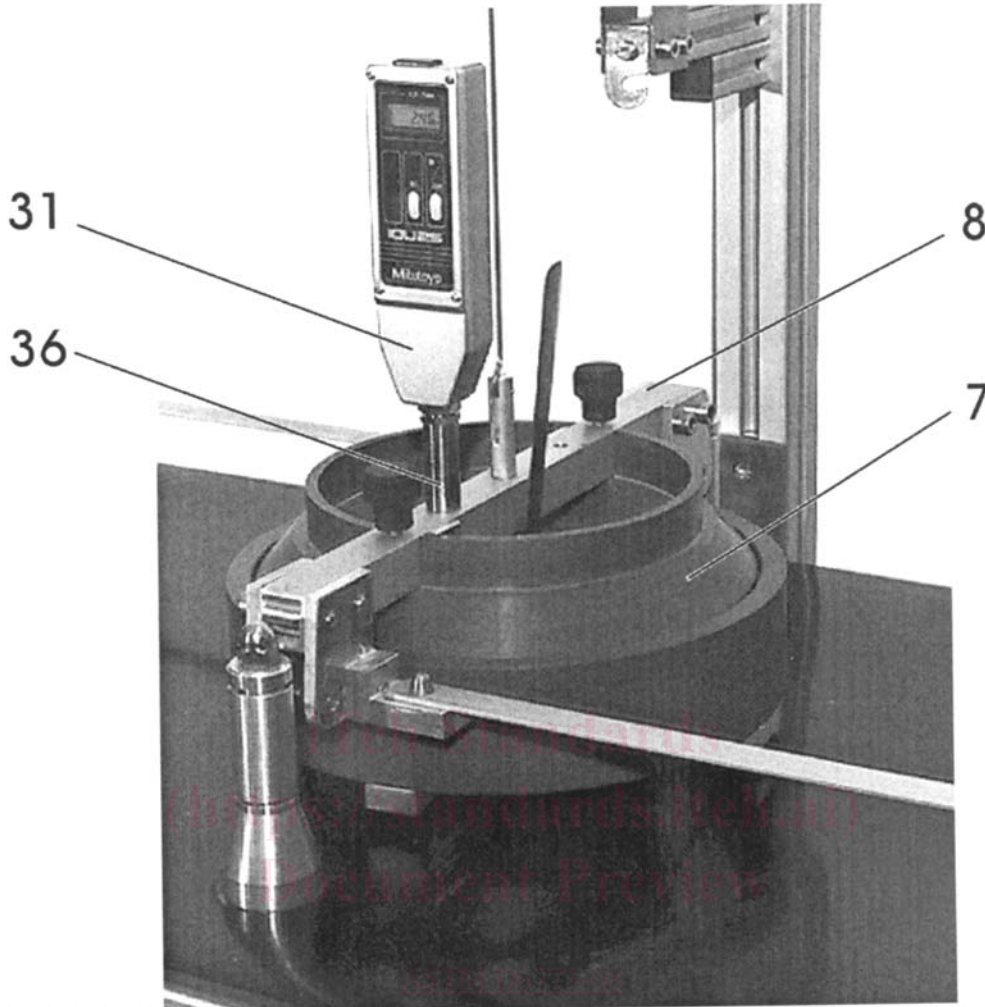

FIG. 7 Determination of the Height of The Specimen

8.1.2.8 Carefully put a ~~weight~~ an applied mass piece on the circular plate 19 of hanger 11 (~~weight~~ mass needed for preshear or smaller ~~weight~~ mass).

8.1.2.9 Remove hook 14, which is connected to the balance arm, from its off-position mounting 32 and append it to the central axis 10 (this already has been done in Fig. 16).

NOTE 7—To do this, the front end of the balance arm must be pulled down at the black handle 46 provided for this (the handle is not shown in all figures; see Fig. 6).

NOTE 8—Follow 8.1.2.10-8.1.2.14 if the normal load at preshear is less than 15 N. (These steps can also be used alternatively to 8.1.2.5-8.1.2.9.)

8.1.2.10 Connect crossbeam 8 and lid 7 using the knurled screws 9. Fasten screws only very slightly. Remove hook 14, which is connected to the balance arm, from its off-position at mounting 32 and append it to the central axis 10. The lid is then in a “lifted position.”

8.1.2.11 Put at least one ~~weight~~ applied mass piece on the circular plate 19 of the hanger 11.

NOTE 9—The mass on the hanger can be less than or equal to that needed for preshear, but should not exceed 1 kg.

8.1.2.12 Hold the lid in its lifted position with one hand and append hanger 11 at hook 25 at the lower side of crossbeam 8.

8.1.2.13 Carefully place the lid concentrically on the shear cell on the bulk solid ~~sample~~ specimen. The lid must be in a position turned a few degrees counterclockwise to its shear position (shear position: longitudinal axis of the crossbeam is perpendicular to the front edge of the casing 2). The open side of hook 25 in the center of crossbeam 8 should be directed to the right. Locate handle 24 of hanger 11 on the right side of crossbeam 8 (Fig. 16).

8.1.2.14 Put tie rods 13 on both the bolts at the ends of crossbeam 8 (circular holes of tie rods 13) and the seatings 16 at load beams 17 (long hole of the tie rod 13).

NOTE 10—The tie rods 13 should have some clearance in the seatings 16; that is, the tie rods must not be stressed at this stage. If it is not possible

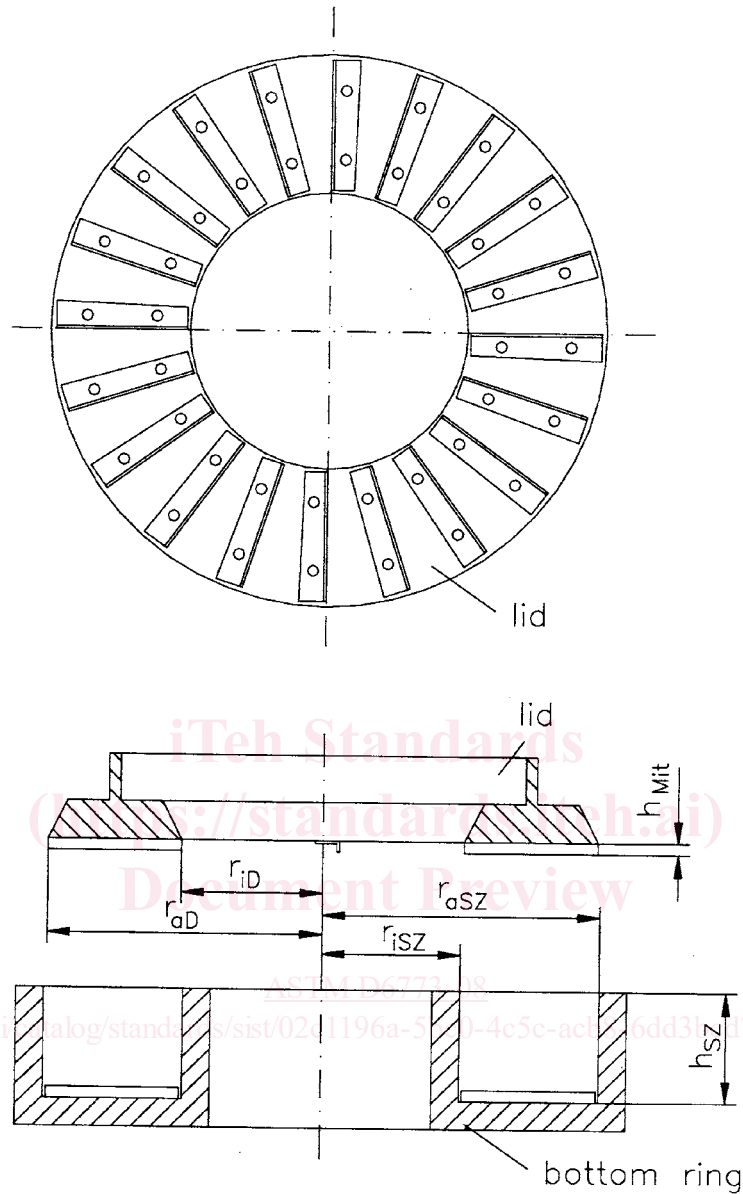

FIG. 8 Main Dimensions of Shear Cell

TABLE 2 Shear Cell Dimensions

	Standard Cell, Type M	Small Cell, Type S
Internal volume V_{SZ}	ca. 900 cm ³ ^A	ca. 200 cm ³ ^A
Cross-section (lid) A_D	226 cm ²	79 cm ²
r_{iD}	51 mm	31 mm
r_{aD}	99 mm	59 mm
r_{iSZ}	50 mm	30 mm
r_{aSZ}	100 mm	60 mm
h_{SZ}	40 mm	24 mm
h_{Mit}	4 mm	4 mm
Material	Aluminum or Stainless Steel	Aluminum or Stainless Steel

^A Exact volume to be determined for each cell.

to connect the tie rods as described above, use the motor drive to turn the shear cell with the lid to an appropriate position.

8.1.2.15 If not already done (at 8.1.2.8 or 8.1.2.11, respectively), put additional weight applied mass pieces on the hanger 11 for adjusting the normal force required for preshear. If the lid sinks down more than around 10 mm, refill the shear cell (remove the shear cell from the tester and go back to 7.1).