



Designation: E953/E953M – 08

## Standard Test Method for Fusibility of Refuse-Derived Fuel (RDF) Ash<sup>1</sup>

This standard is issued under the fixed designation E953/E953M; the number immediately following the designation indicates the year of original adoption or, in the case of revision, the year of last revision. A number in parentheses indicates the year of last reapproval. A superscript epsilon ( $\epsilon$ ) indicates an editorial change since the last revision or reapproval.

### 1. Scope

1.1 This test method covers the observation of the temperatures at which triangular pyramids (cones) prepared from RDF ash attain and pass through certain stages of fusing and flow when heated at a specific rate in controlled, mildly-reducing, and oxidizing atmospheres.

1.2 The test method is empirical, and strict observance of the requirements and conditions is necessary to obtain reproducible temperatures and enable different laboratories to obtain concordant results.

1.3 The values stated in either SI units or inch-pound units are to be regarded separately as standard. The values stated in each system may not be exact equivalents; therefore, each system shall be used independently of the other. Combining values from the two systems may result in non-conformance with the standard.

1.4 *This standard does not purport to address all of the safety problems, if any, associated with its use. It is the responsibility of the user of this standard to establish appropriate safety and health practices and determine the applicability of regulatory limitations prior to use.* See Section 6 for additional hazard information.

### 2. Referenced Documents

2.1 *ASTM Standards:*<sup>2</sup>

D5681 Terminology for Waste and Waste Management

E180 Practice for Determining the Precision of ASTM Methods for Analysis and Testing of Industrial and Specialty Chemicals (Withdrawn 2009)<sup>3</sup>

E829 Practice for Preparing Refuse-Derived Fuel (RDF) Laboratory Samples for Analysis (Withdrawn 2002)<sup>3</sup>

<sup>1</sup> This test method is under the jurisdiction of ASTM Committee D34 on Waste Management and is the direct responsibility of Subcommittee D34.03.02 on Municipal Recovery and Reuse (Disbanded 06/09).

Current edition approved Sept. 1, 2008. Published November 2008. Originally approved in 1983. Last previous edition approved in 2004 as E953 – 88 (2004). DOI: 10.1520/E0953\_E0953M-08.

<sup>2</sup> For referenced ASTM standards, visit the ASTM website, www.astm.org, or contact ASTM Customer Service at service@astm.org. For *Annual Book of ASTM Standards* volume information, refer to the standard's Document Summary page on the ASTM website.

<sup>3</sup> The last approved version of this historical standard is referenced on www.astm.org.

### 3. Terminology

3.1 *Definitions and Symbols*—The critical temperature points to be observed are as follows, denoting the atmosphere used:

3.2 *initial deformation temperature, IT*—the temperature at which the first rounding of the apex of the cone occurs. Shrinking or warping of the cone is ignored if the tip remains sharp. In Fig. 1, the first cone shown is an unheated one; the second cone, IT, is a typical cone at the initial deformation stage.

3.3 *softening temperature, ST*—the temperature at which the cone has fused down to a spherical lump in which the height is equal to the width at the base as shown by the third cone, ST, in Fig. 1.

3.4 *hemispherical temperature, HT*—the temperature at which the cone has fused down to a hemispherical lump at which point the height is one half the width of the base as shown by the fourth cone, HT, in Fig. 1.

3.5 *fluid temperature, FT*—the temperature at which the fused mass has spread out in a nearly flat layer with a maximum height of 1.6 mm [ $1/16$  in.] as shown in the fifth cone, FT, in Fig. 1.

3.6 For definitions of additional terms used in this test method, refer to Terminology D5681.

### 4. Significance and Use

4.1 The standard is available to producers and users of RDF to use in determining the fusibility of ash produced from RDF.

4.2 *Limitations of Ash Fusibility Data*—Ash fusibility data are too often over-interpreted. In practice, types of burning equipment, rate of burning, temperature and thickness of fire bed or ball, distribution of ash forming mineral matter in the RDF, and viscosity of the molten ash may influence ash behavior more than the ash fusibility characteristics determined by the laboratory test. Furthermore, conditions existing during applied combustion of RDF are so complex that they are impossible to duplicate completely in a small-scale laboratory test. Therefore, the test should be considered an empirical one and the data, at best, only qualitative.

### 5. Apparatus

5.1 *Furnace*—Any gas-fired or electric furnace conforming to the following requirements may be used.



FIG. 1 Critical Temperature Points

5.1.1 The furnace shall be capable of maintaining a uniform temperature zone in which to heat the ash cones. This zone shall be such that the difference in the melting point of 12.7 mm [½ in.] pieces of pure gold wire when mounted in place of the ash cones on the cone support shall be not greater than 11°C [20°F] in a reducing atmosphere test run.

5.1.2 The furnace shall be capable of maintaining the desired atmosphere surrounding the cones during heating. The composition of the atmosphere, reducing or oxidizing, shall be maintained within the limits specified in Section 7. The desired atmosphere in the gas-fired furnace surrounding the cones shall be obtained by regulation of the ratio of gas to air in the combustion mixture. The desired atmosphere in the electric furnace shall be obtained by means of gases introduced into the heating chamber. The muffle shall be gas-impervious, free from cracks, and the closure-plug tight fitting. Since state-of-the-art furnaces vary somewhat in design, the gas supply inlet tube shall be installed per instructions of furnace manufacturer.

5.1.3 The furnace shall be capable of regulation so that the rate of temperature rise shall be  $8 \pm 3^\circ\text{C}$  [ $15 \pm 5^\circ\text{F}$ ] per minute.

5.1.4 The furnace shall provide a means of observing the ash cones during the heating. Observation shall be on the same horizontal plane as the cone-support surface.

5.2 Cone Mold—A commercially available cone mold as shown in Fig. 2 shall be used. The cone shall be 19 mm [¾ in.]

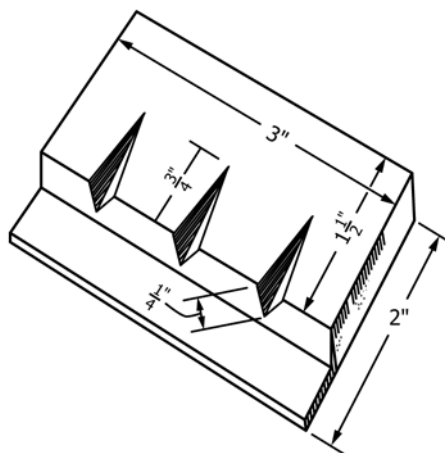

Inch-pound Units, in.	SI Units, mm
¼	6.4
¾	19.1
1½	38.1
2	50.2
3	76.2

FIG. 2 Brass Cone Mold

in height and 6.4 mm [¼ in.] in width at each side of the base which is an equilateral triangle.

5.2.1 A steel spatula with a pointed tip, ground off to fit the cone depression in the mold, is suitable for removal of the ash cone.

5.3 Optical Pyrometer or Thermocouple, for temperature measurements, conforming to the following requirements:

5.3.1 Optical Pyrometer—An optical pyrometer of the disappearing filament type shall be used. The instrument shall have been calibrated to be accurate within 11°C [20°F] up to 1400°C [2550°F] and within 16°C [30°F] from 1400 to 1600°C [2550°F to 2900°F] (Note 1). The pyrometer filament shall be sighted on the cones until the softening point temperature (Fig. 1) has been passed, and then sighted on the cone support. The pyrometer shall have readable graduations not larger than 5.5°C [10°F].

NOTE 1—The pyrometer equipment shall be standardized periodically by a suitably equipped standardizing laboratory such as that of the National Bureau of Standards, or checked periodically against equipment certified by the National Bureau of Standards.

5.3.2 Thermocouple—A thermocouple of platinum and platinum-rhodium, protected from the furnace gases by a glazed porcelain sheath, shall be used with a high-resistance millivoltmeter or potentiometer accurate and readable to within 5.5°C [10°F]. The sheath shall be sealed to the furnace wall by alundum cement. The hot junction of the thermocouple shall touch the end of the sheath and shall be located in the center of the muffle and immediately to the rear of the cones. The thermocouple protective sheath shall be checked periodically for cracks. The thermocouple and its meter shall meet the requirements of Section 10. The potentiometer or millivoltmeter shall be located or shielded adequately as to prevent radiant or convection heating of the cold junction. The room temperature compensator shall be adjusted to the existing temperature.

5.4 Ash-Cone Refractory Support—The ash cone shall be mounted on a refractory base composed of a mixture of equal parts by weight of kaolin and alumina conforming to the following requirements:

5.4.1 Kaolin—NF-Grade powder passing a 75-µm [No. 200] sieve.

5.4.2 Aluminum Oxide—Reagent grade powder passing a 150-µm [No. 100] sieve.

5.5 Refractory Support Mold—A mold with flat top and bottom surfaces to provide a refractory support of suitable thickness to minimize warping shall be used. A side mold not over 6.4 mm [¼ in.] high of any convenient shape, placed on an iron plate so that the top surface of the refractory mix can be struck off flat and parallel to the base by means of a straightedge, is satisfactory. For electric furnace use, legs not over 3 mm [⅛ in.] long may be provided on the corners of the cone support by suitable holes bored in the iron base plate of the mold.

5.6 Gold Wire, <sup>4</sup> Twenty-four gage or larger round wire of 99.98 % purity, but drawn from metal of 99.99 % purity, and having a melting point of 1063°C [1945°F].

<sup>4</sup> Gold wire of this purity can be purchased from the Baker Dental Division of Engelhard Industries, Inc., 850 Passaic Ave., East Newark, NJ 07029.