



SLOVENSKI STANDARD

SIST EN 914:2020

01-julij-2020

Nadomešča:
SIST EN 914:2009

Gimnastična oprema - Bradlja in dvovišinska bradlja - Zahteve in preskusne metode, vključno z varnostjo

Gymnastic equipment - Parallel bars and combination asymmetric/parallel bars - Requirements and test methods including safety

Turngeräte - Barren und kombinierte Stufenbarren/Barren - Anforderungen und Prüfverfahren einschließlich Sicherheit

Matériel de gymnastique - Barres parallèles et barres parallèles/asymétriques combinées - Exigences et méthodes d'essai y compris la sécurité

Ta slovenski standard je istoveten z: EN 914:2020

ICS:

97.220.30 Oprema za dvoranske športe Indoor sports equipment

SIST EN 914:2020

en,fr,de

iTeh STANDARD PREVIEW
(standards.iteh.ai)

SIST EN 914:2020

<https://standards.iteh.ai/catalog/standards/sist/30abb142-a894-4bf5-9b8b-20e547747363/sist-en-914-2020>

EUROPEAN STANDARD
NORME EUROPÉENNE
EUROPÄISCHE NORM

EN 914

May 2020

ICS 97.220.30

Supersedes EN 914:2008

English Version

**Gymnastic equipment - Parallel bars and combination
asymmetric/parallel bars - Requirements and test
methods including safety**

Matériel de gymnastique - Barres parallèles et barres
parallèles/asymétriques combinées - Exigences et
méthodes d'essai y compris de sécurité

Turngeräte - Barren und kombinierte
Stufenbarren/Barren - Anforderungen und
Prüfverfahren einschließlich Sicherheit

This European Standard was approved by CEN on 20 April 2020.

CEN members are bound to comply with the CEN/CENELEC Internal Regulations which stipulate the conditions for giving this European Standard the status of a national standard without any alteration. Up-to-date lists and bibliographical references concerning such national standards may be obtained on application to the CEN-CENELEC Management Centre or to any CEN member.

iTeh STANDARD PREVIEW

This European Standard exists in three official versions (English, French, German). A version in any other language made by translation under the responsibility of a CEN member into its own language and notified to the CEN-CENELEC Management Centre has the same status as the official versions.

CEN members are the national standards bodies of Austria, Belgium, Bulgaria, Croatia, Cyprus, Czech Republic, Denmark, Estonia, Finland, France, Germany, Greece, Hungary, Iceland, Ireland, Italy, Latvia, Lithuania, Luxembourg, Malta, Netherlands, Norway, Poland, Portugal, Republic of North Macedonia, Romania, Serbia, Slovakia, Slovenia, Spain, Sweden, Switzerland, Turkey and United Kingdom.



EUROPEAN COMMITTEE FOR STANDARDIZATION
COMITÉ EUROPÉEN DE NORMALISATION
EUROPÄISCHES KOMITEE FÜR NORMUNG

CEN-CENELEC Management Centre: Rue de la Science 23, B-1040 Brussels

Contents	Page
European foreword.....	4
1 Scope	5
2 Normative references	5
3 Terms and definitions	5
4 Requirements	5
4.1 Classification.....	5
4.2 Dimensions.....	6
4.3 Protection against damaging the floor.....	7
4.4 Gap between the longitudinal/cross member.....	7
4.5 Transport equipment.....	8
5 Safety requirements	8
5.1 General requirements.....	8
5.2 Clear path between uprights.....	8
5.3 Entrapment.....	8
5.4 Stability.....	8
5.5 Vertical stiffness and residual deflection.....	8
5.6 Strength.....	8
5.7 Rigidity of framework.....	9
6 Test methods	9
6.1 General.....	9
6.2 Determination of the clear path between uprights.....	9
6.2.1 Principle.....	9
6.2.2 Apparatus.....	9
6.2.3 Procedure.....	9
6.2.4 Expression of results.....	9
6.3 Determination of stability and rigidity.....	10
6.3.1 Principle.....	10
6.3.2 Apparatus.....	10
6.3.3 Test temperature.....	10
6.3.4 Procedure.....	10
6.3.5 Expression of results.....	11
6.4 Determination of stiffness and residual deflection.....	11
6.4.1 Principle.....	11
6.4.2 Apparatus.....	11
6.4.3 Test temperature.....	11
6.4.4 Procedure.....	11
6.4.5 Expression of results.....	11
6.5 Determination of strength.....	11
6.5.1 Principle.....	11
6.5.2 Apparatus.....	11
6.5.3 Test temperature.....	11
6.5.4 Procedure.....	11
6.5.5 Expression of results.....	12
7 Instructions for use	12

8	Marking	12
	Annex A (informative) Example of a cross section of equipment	13
	Bibliography	14

iTeh STANDARD PREVIEW
(standards.iteh.ai)

[SIST EN 914:2020](https://standards.iteh.ai/catalog/standards/sist/30abb142-a894-4bf5-9b8b-20e547747363/sist-en-914-2020)

<https://standards.iteh.ai/catalog/standards/sist/30abb142-a894-4bf5-9b8b-20e547747363/sist-en-914-2020>

EN 914:2020 (E)**European foreword**

This document (EN 914:2020) has been prepared by Technical Committee CEN/TC 136 “Sports, playground and other recreational facilities and equipment”, the secretariat of which is held by DIN.

This European Standard shall be given the status of a national standard, either by publication of an identical text or by endorsement, at the latest by November 2020, and conflicting national standards shall be withdrawn at the latest by November 2020.

Attention is drawn to the possibility that some of the elements of this document may be the subject of patent rights. CEN shall not be held responsible for identifying any or all such patent rights.

This document supersedes EN 914:2008.

This document has been prepared under a mandate given to CEN by the European Commission and the European Free Trade Association.

This European Standard is one of several standards, each of which deals with a particular type or a particular group of gymnastic equipment.

The principal changes from the previous edition of EN 914 are as follows:

- ITeh STANDARD PREVIEW**
(standards.iteh.ai)
- a) adopting a new type (type 3) in Table 1 and Table 2 in conjunction with corresponding numeric values;
 - b) dimension in Figure 1 adapted.

<https://standards.iteh.ai/catalog/standards/sist/30abb142-a894-4b15-9b8b-20e547747363/sist-en-914-2020>
According to the CEN-CENELEC Internal Regulations, the national standards organisations of the following countries are bound to implement this European Standard: Austria, Belgium, Bulgaria, Croatia, Cyprus, Czech Republic, Denmark, Estonia, Finland, France, Germany, Greece, Hungary, Iceland, Ireland, Italy, Latvia, Lithuania, Luxembourg, Malta, Netherlands, Norway, Poland, Portugal, Republic of North Macedonia, Romania, Serbia, Slovakia, Slovenia, Spain, Sweden, Switzerland, Turkey and the United Kingdom.

1 Scope

This document specifies functional requirements (see Clause 4) and specific safety requirements in addition to the general safety requirements in EN 913 (see Clause 5), which is read in conjunction with this standard.

This document is applicable to three types of parallel bars (see Table 1) intended for use under supervision of a competent person.

2 Normative references

The following documents are referred to in the text in such a way that some or all of their content constitutes requirements of this document. For dated references, only the edition cited applies. For undated references, the latest edition of the referenced document (including any amendments) applies.

EN 913, *Gymnastic equipment - General safety requirements and test methods*

EN 12503-1, *Sports mats - Part 1: Gymnastic mats, safety requirements*

EN 12503-4:2016, *Sports mats - Part 4: Determination of shock absorption*

3 Terms and definitions

No terms and definitions are listed in this document.

ISO and IEC maintain terminological databases for use in standardization at the following addresses:

- IEC Electropedia: available at <http://www.electropedia.org/>
- ISO Online browsing platform: available at <https://www.iso.org/obp>

4 Requirements

4.1 Classification

Parallel bars and combination asymmetric parallel bars shall be classified by the design (types and sizes) as shown in Table 1.

Table 1 — Types

Type	Size	Description
1	1 and 2	parallel bars
2	—	combination asymmetric/parallel bars
3a	—	competition parallel bars
^a According to the actual rules of FIG (Fédération Internationale de Gymnastique).		

EN 914:2020 (E)

4.2 Dimensions

All parallel bars and combination asymmetric/parallel bars shall comply with the dimensions specified in Table 2 and Figures 1 and 2.

Suitable profiles are defined in Figure 2.

Dimensions in millimetres

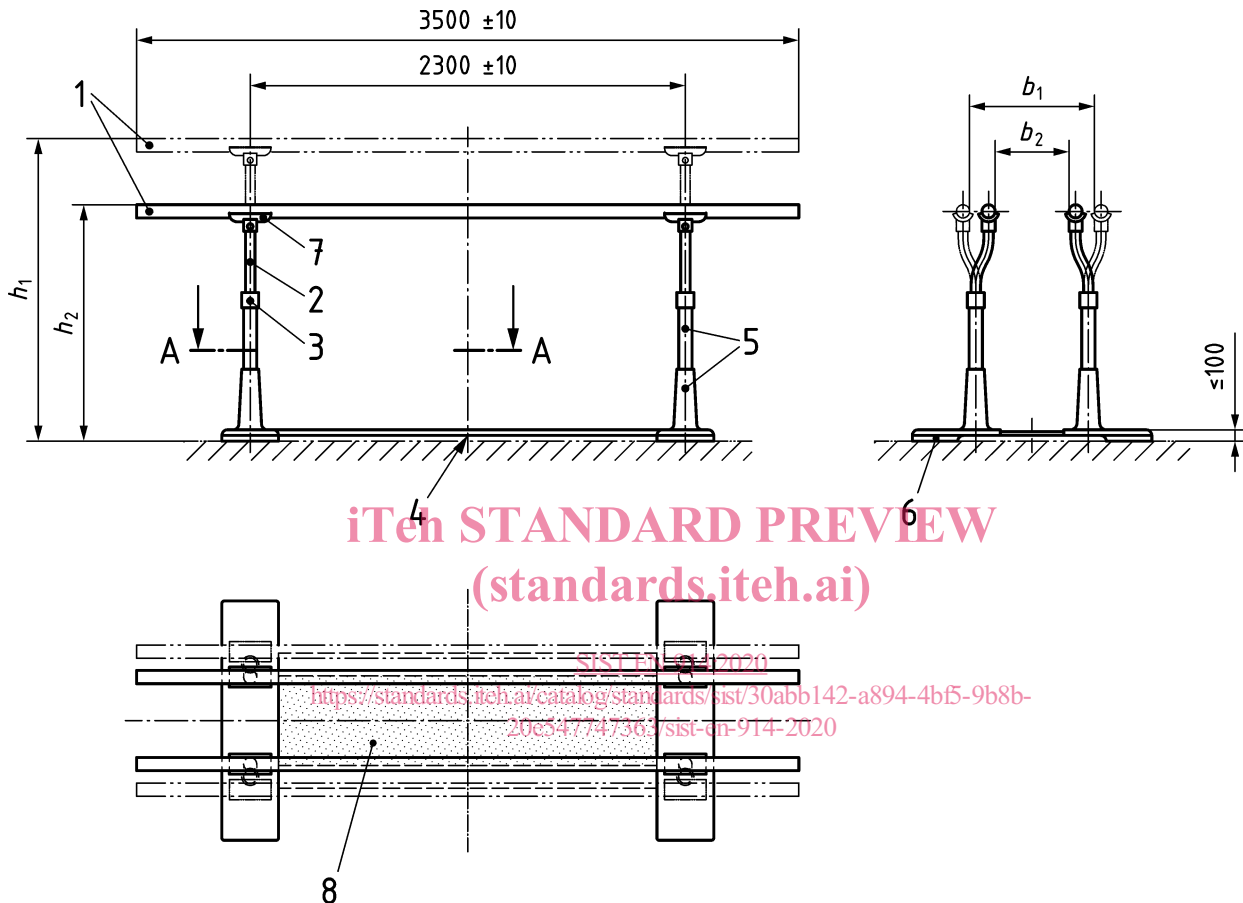

Key

- 1 bar
- 2 upright extension
- 3 stop, lock and adjustment device
- 4 longitudinal member
- 5 upright
- 6 cross member
- 7 supporting cup point
- 8 mat or platform (visual example for Type 1 and 2)

NOTE Section A-A refers to Annex A, in particular Figure A.1.

Figure 1 — Parallel bar and combination asymmetric/parallel bar

Table 2 — Dimensions

Dimensions in millimetres

Type	Size	Minimum range of adjustment		Minimum range of adjustment	
		b_1	b_2	h_1	h_2
1	1	520	to 390	1 600	to 1 250
	2	520	to 390	2 050	to 1 400
2	—	550	to 390	Low bar	
				1 850	to 1 500
				High bar	
		2 300	to 1 500		
3 ^a	—	520	to 420	2 000	to 1 500

^a According to the actual rules of FIG (Fédération Internationale de Gymnastique).

Dimensions in millimetres

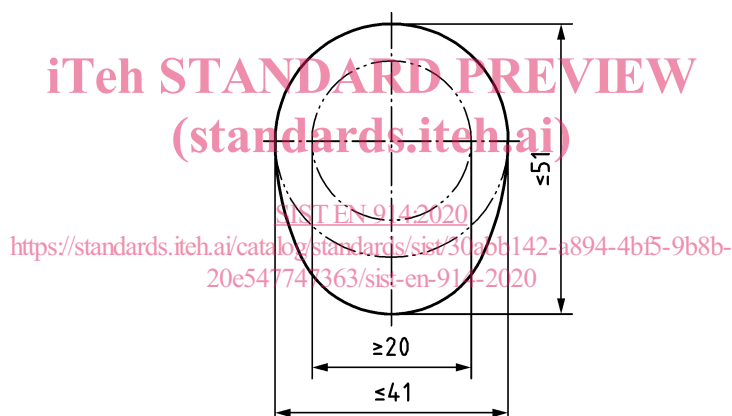

NOTE Any profile lying between the dimensions shown is acceptable.

Figure 2 — Profile of bars

4.3 Protection against damaging the floor

The parallel bars and combination asymmetric/parallel bars shall not damage the floor.

4.4 Gap between the longitudinal/cross member

For Type 1, Type 2 and Type 3 when in use fill the gap between the longitudinal/cross member up to the highest level of the members. This can be achieved by mats according to EN 12503-1 and EN 12503-4 or by a platform base.

For Type 3 when used in competition, the whole framework shall be covered with mats of a total height of 20 cm according to EN 12503-1, and EN 12503-4:2016, Table 1, Type 6.

NOTE For competition FIG (Fédération Internationale de Gymnastique) rules will apply.