**Endoscopes — Medical endoscopes
and endotherapy devices —**

**Part 3:
Determination of field of view and
direction of view of endoscopes with
optics**

iTeh STANDARD PREVIEW

(standards.iteh.ai)
*Endoscopes — Endoscopes médicaux et dispositifs d'endothérapie —
Partie 3: Détermination du champ d'observation et de la direction
d'observation des endoscopes optiques*

<https://standards.iteh.ai/catalog/standards/sist/22afa572-30dd-462e-a153-13074c832afa/iso-8600-3-2019>



iTeh STANDARD PREVIEW
(standards.iteh.ai)

ISO 8600-3:2019

<https://standards.iteh.ai/catalog/standards/sist/22afa572-30dd-462e-a153-13074c832afa/iso-8600-3-2019>



COPYRIGHT PROTECTED DOCUMENT

© ISO 2019

All rights reserved. Unless otherwise specified, or required in the context of its implementation, no part of this publication may be reproduced or utilized otherwise in any form or by any means, electronic or mechanical, including photocopying, or posting on the internet or an intranet, without prior written permission. Permission can be requested from either ISO at the address below or ISO's member body in the country of the requester.

ISO copyright office
CP 401 • Ch. de Blandonnet 8
CH-1214 Vernier, Geneva
Phone: +41 22 749 01 11
Fax: +41 22 749 09 47
Email: copyright@iso.org
Website: www.iso.org

Published in Switzerland

Contents

	Page
Foreword	iv
1 Scope	1
2 Normative references	1
3 Terms and definitions	1
4 Requirements	1
4.1 General.....	1
4.2 Measurement accuracy (field of view).....	2
4.3 Measurement accuracy (direction of view).....	2
5 Apparatus	2
5.1 Method A (distal window reference).....	2
5.2 Method B (entrance pupil reference).....	2
6 Test methods	3
6.1 Method A.....	3
6.2 Method B.....	3
7 Test report	4
Bibliography	8

iTeh STANDARD PREVIEW (standards.iteh.ai)

ISO 8600-3:2019

<https://standards.iteh.ai/catalog/standards/sist/22afa572-30dd-462e-a153-13074c832afa/iso-8600-3-2019>

Foreword

ISO (the International Organization for Standardization) is a worldwide federation of national standards bodies (ISO member bodies). The work of preparing International Standards is normally carried out through ISO technical committees. Each member body interested in a subject for which a technical committee has been established has the right to be represented on that committee. International organizations, governmental and non-governmental, in liaison with ISO, also take part in the work. ISO collaborates closely with the International Electrotechnical Commission (IEC) on all matters of electrotechnical standardization.

The procedures used to develop this document and those intended for its further maintenance are described in the ISO/IEC Directives, Part 1. In particular the different approval criteria needed for the different types of ISO documents should be noted. This document was drafted in accordance with the editorial rules of the ISO/IEC Directives, Part 2 (see www.iso.org/directives).

Attention is drawn to the possibility that some of the elements of this document may be the subject of patent rights. ISO shall not be held responsible for identifying any or all such patent rights. Details of any patent rights identified during the development of the document will be in the Introduction and/or on the ISO list of patent declarations received (see www.iso.org/patents).

Any trade name used in this document is information given for the convenience of users and does not constitute an endorsement.

For an explanation on the voluntary nature of standards, the meaning of ISO specific terms and expressions related to conformity assessment, as well as information about ISO's adherence to the World Trade Organization (WTO) principles in the Technical Barriers to Trade (TBT) see the following URL: www.iso.org/iso/foreword.html. (standards.iteh.ai)

The committee responsible for this document is ISO/TC 172, *Optics and photonics*, Subcommittee SC 5, *Microscopes and endoscopes*.
ISO 8600-3:2019

<https://standards.iteh.ai/catalog/standards/sist/22afa572-30dd-462e-a153-1b07f832-ed10/iso-8600-3-2019>

This second edition cancels and replaces the first edition (ISO 8600-3:1997). It also incorporates the Amendment ISO 8600-3:1997/Amd 1:2003.

A list of all parts in the ISO 8600 series can be found on the ISO website.

Any feedback or questions on this document should be directed to the user's national standards body. A complete listing of these bodies can be found at www.iso.org/members.html.

Endoscopes — Medical endoscopes and endotherapy devices —

Part 3:

Determination of field of view and direction of view of endoscopes with optics

1 Scope

This document applies to endoscopes designed for use in the practice of medicine. It specifies measurement requirements and describes two test methods for measuring the field of view and direction of view of endoscopes. Method A uses the distance from the distal window to calculate the field of view. Method B uses the distance from the entrance pupil. Other test methods can be used if they obtain equivalent results.

2 Normative references

The following documents are referred to in the text in such a way that some or all of their content constitutes requirements of this document. For dated references, only the edition cited applies. For undated references, the latest edition of the referenced document (including any amendments) applies.

ISO 8600-1, *Endoscopes — Medical endoscopes and endotherapy devices — Part 1: General requirements*

ISO 8600-6, *Optics and photonics — Medical endoscopes and endotherapy devices — Part 6: Vocabulary*

3 Terms and definitions

For the purposes of this document, the terms and definitions given in ISO 8600-1 and ISO 8600-6 apply.

ISO and IEC maintain terminological databases for use in standardization at the following addresses:

- ISO Online browsing platform: available at <http://www.iso.org/obp>
- IEC Electropedia: available at <http://www.electropedia.org/>

4 Requirements

4.1 General

Method A applies only if the measuring distance is at least 30 times larger than the distance between the distal end and the entrance pupil^[1] and the accuracy requirement in ISO 8600-1 is satisfied. Otherwise, the error caused by the distance between the distal end and the entrance pupil in Method A will lead to a systematic measurement error.

Method B may be used at any distance. In general, any method is allowed which has the entrance pupil as reference. Details about test Method A and Method B for measuring endoscope field of view and direction of view, including their shortcomings, accuracies, application prerequisites (e.g. endoscopes with a close focus distance and capsule endoscopes should only use Method B), etc., can be found in the reference^[1].

4.2 Measurement accuracy (field of view)

Measurement accuracy shall be sufficient to be in accordance with ISO 8600-1.

4.3 Measurement accuracy (direction of view)

Measurement accuracy shall be sufficient to be in accordance with ISO 8600-1.

5 Apparatus

5.1 Method A (distal window reference)

5.1.1 General

Method A uses the distance from the distal window to calculate the field of view. Method A is acceptable for most traditional rigid and flexible endoscopes because the measuring distance is much longer than the distance between the distal window and the entrance pupil of the measured endoscope (see 4.1).

5.1.2 Optical bench, or equivalent device to support the endoscope being tested while aligning the target perpendicular to the central axis of the field of view. The device should allow adjustment of the central axis of the field of view to the centre of the target. The device should also have the capability to adjust and measure the distance from the target to the distal window over the range of 0 to 50 mm ± 0,2 mm. If the depth of field of the endoscope does not include 50 mm, then the bench should allow the target to be placed at the measuring distance specified by the manufacturer. See [Figure 1](#).

5.1.3 Target holder and protractor graduated in degrees. See [Figure 1](#).

5.1.4 Target for field of view and direction of view tests (see [Figure 2](#)) round shape, with circles showing the field of view β , in degrees, from a distance of 50 mm computed as:

$$D_{\text{mm}} = 100 \tan \frac{\beta}{2}$$

where D_{mm} are the diameters of the circles in mm.

Major divisions shall be marked every 10° with the corresponding number in degrees. Between each major division, four finer marks shall indicate every 2°. If the depth of field of the endoscope does not include 50 mm, then an adjusted target, designed to measure the field of view at the measuring distance specified by the manufacturer, should be used.

5.1.5 Illumination source: White light target illumination shall be provided with intensity sufficient to visually identify the target structure throughout the endoscope field of view. The illumination can be delivered using either the endoscope illumination or an external source.

5.2 Method B (entrance pupil reference)

5.2.1 General

Method B uses the distance from the entrance pupil and may be used for all rigid, flexible, and capsule endoscopes.

5.2.2 Optical bench or equivalent device, to support the endoscope being tested while aligning the target perpendicular to the central axis of the field of view. The device should allow adjustment of the central axis of the field of view to the centre of the target. The device should also have the capability to adjust and measure the distance from the target to the distal window over a sufficient range so that each

of the concentric circles on the target can be coincident with the maximum diagonal field of view. See [Figure 1](#).

5.2.3 Target holder and protractor graduated in degrees. See [Figure 1](#).

5.2.4 Target for field of view and direction of view tests, (see [Figure 3](#)) round shape, with two concentric circles of known size (radii of r_1 and r_2) and a crosshair at the centre of the circles. It is recommended that $r_1 = 18$ mm and $r_2 = 9$ mm, however other sizes are acceptable if the depth of field or field of view does not allow the endoscope to be properly focused on the specified target sizes when used according to the procedure.

5.2.5 Illumination source. white light target-illumination shall be provided with intensity sufficient to visually identify the target structure throughout the endoscope field of view. The illumination can be delivered using either the endoscope illumination or an external source.

6 Test methods

6.1 Method A

- a) Mount the target into the target holder. Adjust target in such a way that its perpendicular line through its centre intersects the centre of rotation stage.
- b) Mount the endoscope to be tested in the endoscope holder in such a manner that the centre of the distal window is 50 mm \pm 0,2 mm from the target centre. Adjust the endoscope in a way that its entrance pupil (if unknown, distal window) is at the centre of the rotation stage.
- c) If the depth of field of the endoscope does not include 50 mm, then the endoscope should be mounted at the measuring distance specified by the manufacturer \pm 1 % from a target designed to measure the field of view at that measuring distance. Record the measuring distance.
- d) Adjust the endoscope holder by looking through the endoscope so that the circles marked on the target and the circumference of the field of view is centred.
- e) Determine the largest viewed circle and record it as the field of view, in degrees. For a non-circular image, only segments of the largest circle may be visible.
- f) Read and record as the direction of view the angular position, in degrees, of the protractor relative to the long axis of the insertion portion of the endoscope.

6.2 Method B

- a) Mount the target into the target holder.
- b) Mount the endoscope to be tested in the endoscope holder with the distal window within 0,5 mm of the target. Sharp image focus might not be possible to achieve at this distance. Adjust the endoscope in a way that its entrance pupil (if unknown, distal window) is at the centre of rotation of the rotation stage.
- c) Adjust the endoscope holder by looking through the endoscope so that the crosshairs marked on the target and the circumference of the field of view is centred.
- d) Move the target away from the endoscope until the outer target circle with radius r_1 is fully in view. Adjust the viewing direction from the endoscope to the target holder by looking through the endoscope so that the circles marked on the target and the circumference of the field of view is centred.

- e) Move the target back to within 0,5 mm of the distal window and confirm that the crosshairs marked on the target and the circumference of the field of view are still centred. If they are not, adjust the viewing direction and repeat steps 6.2 b) through 6.2 e) until both features are centred.
- f) Record the distance (d_1) from the endoscope to the target with the outer target circle (r_1) coincident with the maximum diagonal field of view.
- g) Move the target toward the endoscope until the inner target circle with radius r_2 is coincident with the maximum diagonal field of view. Record the distance (d_2) from the endoscope to the target.
- h) Calculate and record the field of view (FOV) of the endoscope in degrees according to the formula:

$$\text{FOV} = 2 \times \arctan \left(\frac{r_1 - r_2}{d_1 - d_2} \right)$$

See [Figure 4](#).

- i) Read and record as the direction of view the angular position, in degrees, of the protractor relative to the long axis of the insertion portion of the endoscope.

7 Test report

Any test report shall contain at least the following information:

- a) the International Standard used (including its year of publication);
- b) the type of endoscope, manufacturer, model, and serial number;
- c) the method used;
- d) measuring distance between target and distal end of endoscope;
- e) measured field of view in degrees and measurement uncertainties for 95 % confidence interval;
- f) measured direction of view in degrees and measurement uncertainties for 95 % confidence interval;
- g) the laboratory or company carrying out the test;
- h) the name of the testing engineer;
- i) the place and date of test;
- j) any deviations from the procedure;
- k) any unusual features observed.

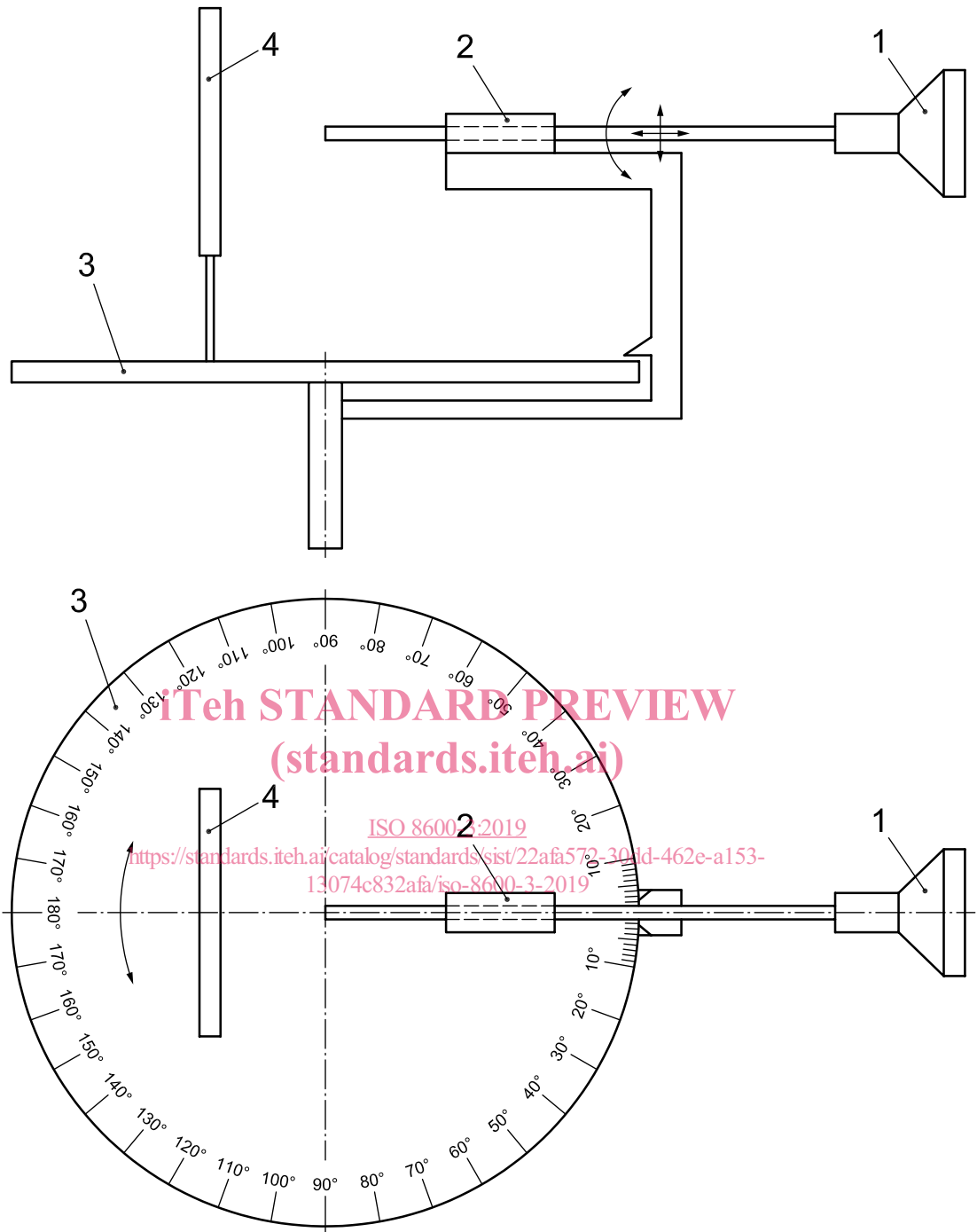

Key

- 1 optical endoscope
- 2 optical bench
- 3 target holder and protractor
- 4 target

Figure 1 — Example of a test device (schematic) for Method A and B