



**SLOVENSKI STANDARD**  
**oSIST prEN 12016:2018**  
**01-marec-2018**

---

**Elektromagnetna združljivost - Standard skupine izdelkov za dvigala (lifte), tekoče stopnice in tekoče steze - Odpornost proti motnjam**

Electromagnetic compatibility - Product family standard for lifts, escalators and moving walks - Immunity

Elektromagnetische Verträglichkeit - Produktfamilien-Norm für Aufzüge, Fahrtreppen und Fahrsteige - Störfestigkeit

Compatibilité électromagnétique - Norme de la famille de produits ascenseurs, escaliers mécaniques et trottoirs roulants - Immunité

<https://standards.iteh.ai/catalog/standards/sist/8093b355-2f2d-4803-8371-a35e75099d35/ksist-pr-en-12016-2019>

**Ta slovenski standard je istoveten z: prEN 12016**

---

**ICS:**

33.100.20	Imunost	Immunity
91.140.90	Dvigala. Tekoče stopnice	Lifts. Escalators

**oSIST prEN 12016:2018**

**en,fr,de**

**iTeh STANDARD PREVIEW**  
**(standards.iteh.ai)**

[kSIST prEN 12016:2019](https://standards.iteh.ai/catalog/standards/sist/8093b355-2f2d-4803-8371-a35e75099d35/ksist-pren-12016-2019)

<https://standards.iteh.ai/catalog/standards/sist/8093b355-2f2d-4803-8371-a35e75099d35/ksist-pren-12016-2019>

EUROPEAN STANDARD  
NORME EUROPÉENNE  
EUROPÄISCHE NORM

**DRAFT**  
**prEN 12016**

January 2018

ICS 33.100.20; 91.140.90

Will supersede EN 12016:2013

English Version

## Electromagnetic compatibility - Product family standard for lifts, escalators and moving walks - Immunity

Compatibilité électromagnétique - Norme de la famille  
de produits ascenseurs, escaliers mécaniques et  
trottoirs roulants - Immunité

Elektromagnetische Verträglichkeit - Produktfamilien-  
Norm für Aufzüge, Fahrtreppen und Fahrsteige -  
Störfestigkeit

This draft European Standard is submitted to CEN members for enquiry. It has been drawn up by the Technical Committee CEN/TC 10.

If this draft becomes a European Standard, CEN members are bound to comply with the CEN/CENELEC Internal Regulations which stipulate the conditions for giving this European Standard the status of a national standard without any alteration.

This draft European Standard was established by CEN in three official versions (English, French, German). A version in any other language made by translation under the responsibility of a CEN member into its own language and notified to the CEN-CENELEC Management Centre has the same status as the official versions.

CEN members are the national standards bodies of Austria, Belgium, Bulgaria, Croatia, Cyprus, Czech Republic, Denmark, Estonia, Finland, Former Yugoslav Republic of Macedonia, France, Germany, Greece, Hungary, Iceland, Ireland, Italy, Latvia, Lithuania, Luxembourg, Malta, Netherlands, Norway, Poland, Portugal, Romania, Serbia, Slovakia, Slovenia, Spain, Sweden, Switzerland, Turkey and United Kingdom.

Recipients of this draft are invited to submit, with their comments, notification of any relevant patent rights of which they are aware and to provide supporting documentation.

**Warning** : This document is not a European Standard. It is distributed for review and comments. It is subject to change without notice and shall not be referred to as a European Standard.



EUROPEAN COMMITTEE FOR STANDARDIZATION  
COMITÉ EUROPÉEN DE NORMALISATION  
EUROPÄISCHES KOMITEE FÜR NORMUNG

**CEN-CENELEC Management Centre: Rue de la Science 23, B-1040 Brussels**

<b>Contents</b>	<b>Page</b>
European foreword.....	3
Introduction .....	4
1 Scope.....	6
2 Normative references.....	6
3 Terms and definitions .....	7
4 Test procedure.....	10
5 Applicability of tests.....	11
6 Evaluation of tests results.....	12
6.1 Introduction .....	12
6.2 Performance criteria .....	12
6.3 Enclosure ports of safety circuits .....	12
7 Documentation for the installer of the apparatus/assembly of apparatus .....	13
Annex ZA (informative) Relationship between this European standard and the essential requirements of Directive 2014/30/EU aimed to be covered.....	21
Annex ZB (informative) Relationship between this European Standard and the essential requirements of Directive 2006/42/EC aimed to be covered .....	22
Annex ZC (informative) Relationship between this European Standard and the essential requirements of Directive 2014/33/EU aimed to be covered.....	23
Bibliography.....	24

## European foreword

This document (prEN 12016:2018) has been prepared by Technical Committee CEN/TC 10 “Lifts, escalators and moving walks”, the secretariat of which is held by AFNOR.

This document is currently submitted to the CEN Enquiry.

This document will supersede EN 12016:2013.

This document has been prepared under a mandate given to CEN by the European Commission and the European Free Trade Association, and supports essential requirements of EU Directive(s).

For relationship with EU Directive(s), see informative Annexes ZA, ZB and ZC, which are an integral part of this document.

The test levels and the performance criteria which are given in this European Standard reflect the fact that lifts, escalators and moving walks, when in use, consist generally of self-contained apparatus (e.g. machine room, car, etc.).

The related EMC product family standard for emission is:

— EN 12015, *Electromagnetic compatibility — Product family standard for lifts, escalators and moving walks — Emission*

(standards.iteh.ai)

[ksIST prEN 12016:2019](https://standards.iteh.ai/catalog/standards/sist/8093b355-2f2d-4803-8371-a35e75099d35/ksist-pren-12016-2019)

<https://standards.iteh.ai/catalog/standards/sist/8093b355-2f2d-4803-8371-a35e75099d35/ksist-pren-12016-2019>

## Introduction

This document is a Type C standard as stated in EN ISO 12100.

This document has been prepared to provide one means of conforming to the requirements of the Electromagnetic Compatibility (EMC) Directive, the Lifts Directive and the Machinery Directive. The requirements of this European Standard have been specified so as to ensure an adequate level of electromagnetic immunity for most cases.

The apparatus concerned and the extent to which hazards, hazardous situations or hazardous events are covered are indicated in the Scope of this document.

When requirements of this type C standard are different from those which are stated in type-A or type-B standards, the requirements of this type C standard take precedence over the requirements of the other standards for apparatus that have been designed and built according to the requirements of this type C standard.

Test levels and immunity performance criteria are defined for:

- apparatus which are safety components or are used in conjunction with safety components, (safety circuits);
- apparatus used in general function circuits.

The test levels and requirements are given on the basis that the apparatus, generally, is connected to a low voltage system.

The requirements for safety circuits provide one means of demonstrating conformity with the essential health and safety requirements of the Lifts Directive and the Machinery Directive with regard to immunity against electromagnetic phenomena.

Due to the size of an installed lift, it becomes impracticable to test the total assembly either in a test laboratory or *in situ* where the uncontrolled environment may also influence the test procedures and results. This applies also to measurements within the car. Similar considerations regarding dimensions apply equally to the testing of escalators and moving walks.

### Rational to the revision of the standard EN 12016:1998

#### a) Important changes

The Scope excludes severe electromagnetic environments and apparatus already proven to be in conformity with the Electromagnetic Compatibility Directive.

The term “installation” has been changed to “system”. This is due to the fact that official interpretation defines that fixed installations are not covered by the conformity assessment procedures for CE marking and declaration of conformity according to the EMC Directive. The scope of the standard is applicable to the apparatus and assembly of apparatus of lifts and escalators and assembly into systems.

New requirements on radio frequency electromagnetic field above 500 MHz, these are extended to cover the digital mobile telephone services up to 1960 MHz.

New requirements for surge testing on safety circuits.

New requirements on radio frequency electromagnetic field regarding safety devices as defined by the Lifts Directive and mobile telephones or radio-transmitters as a result of a risk assessment. It is assumed that mobile telephones and radio-transmitters are not used at frequencies up to 166 MHz near safety circuits of equipment covered by the scope of this standard.

Higher requirements on several environmental phenomena considering the progress on EMC technology and the results of the risk assessment.

New requirements have been introduced for immunity to mains power supply voltage interruptions and voltage dips.

#### **b) Environmental issues**

Lifts, escalators and moving walks are systems whose component apparatus/assembly of apparatus are distributed (and some of which move) throughout the building. The definition in EMC terms of the use of the building (residential or industrial) cannot be predetermined or assumed to be fixed. Therefore, to cover requirements in all cases, no differentiation between environments has been made and a single set of limits has been maintained.

Severe electromagnetic environments have not been considered. Examples of these are: radio-transmitter stations, railways and metros, heavy industrial plant, electricity power stations. Additional tests and immunity measures may need to be taken on apparatus to be used in these environments.

It is assumed that no ports connected to safety circuit only are rated at currents greater than 100 A.

#### **Rational to the revision of the standard EN 12016:2004+A1:2008**

New requirements on radio frequency electromagnetic field to cover the digital mobile telephone services and wireless communication systems up to 2 655 MHz.

Performance criteria requirements for radio equipment and telecommunications terminal equipment as defined by Directive 1999/5/EC used in combined apparatus/assembly of apparatus.

#### **Rational to the revision of the standard EN 12016:2013**

Relationship between this European Standard and EN 81-20.

Relationship between this European Standard and the essential requirements of EU Directive 2014/30/EU.

Relationship between this European Standard and the essential requirements of Directive 2006/42/EC.

Relationship between this European Standard and the essential requirements of Directive 2014/33/EU.

**prEN 12016:2018 (E)****1 Scope**

**1.1** This document specifies the immunity performance criteria and test levels for apparatus used in lifts, escalators and moving walks which are intended to be permanently installed in buildings including the basic safety requirements in regard to their electromagnetic environment. These levels represent essential EMC requirements.

This document refers to EM conditions as existing in residential, office and industrial buildings.

This document addresses commonly known EMC related hazards and hazardous situations relevant to lifts, escalators and moving walks when they are used as intended and under the conditions foreseen by the lift installer or escalator and/or moving walk manufacturer.

However:

- performance criteria and test levels for apparatus/assembly of apparatus used in general function circuits do not cover situations with an extremely low probability of occurrence;
- this document does not apply to other apparatus already proven to be in conformity to the EMC Directive, and not related to the safety of the lift, escalator or moving walk, such as lighting apparatus, communication apparatus, etc.

**1.2** This document does not apply to electromagnetic environments such as:

- radio-transmitter stations,
- railways and metros,
- heavy industrial plant,
- electricity power station,

**ITeh STANDARD PREVIEW**  
**(standards.iteh.ai)**  
<https://standards.iteh.ai/catalog/standards/sist/8093b355-2fd-4803-8371-a35e75099d35/ksist-pren-12016-2019>

which need additional investigations.

**1.3** This document is not applicable to apparatus which were manufactured before the date of its publication as EN 12016.

**2 Normative references**

The following documents are referred to in the text in such a way that some or all of their content constitutes requirements of this document. For dated references, only the edition cited applies. For undated references, the latest edition of the referenced document (including any amendments) applies.

EN 55022:2010, *Information technology equipment - Radio disturbance characteristics - Limits and methods of measurement (CISPR 22:2008, modified)*

EN 55024:2010, *Information technology equipment - Immunity characteristics - Limits and methods of measurement (CISPR 24:2010)*

EN 61000-4-2:2009, *Electromagnetic compatibility (EMC) - Part 4-2: Testing and measurement techniques - Electrostatic discharge immunity test (IEC 61000-4-2:2008)*



EN 61000-4-3:2006, *Electromagnetic compatibility (EMC) - Part 4-3: Testing and measurement techniques - Radiated, radio-frequency, electromagnetic field immunity test* (IEC 61000-4-3:2006)<sup>1)</sup>

EN 61000-4-4:2012, *Electromagnetic compatibility (EMC) - Part 4-4: Testing and measurement techniques - Electrical fast transient/burst immunity test* (IEC 61000-4-4:2012)

EN 61000-4-5:2014, *Electromagnetic compatibility (EMC) - Part 4-5: Testing and measurement techniques — Surge immunity test* (IEC 61000-4-5:2014)

EN 61000-4-6:2014, *Electromagnetic compatibility (EMC) - Part 4-6: Testing and measurement techniques - Immunity to conducted disturbances, induced by radio-frequency fields* (IEC 61000-4-6:2013)

EN 61000-4-11:2004, *Electromagnetic compatibility (EMC) - Part 4-11: Testing and measurement techniques - Voltage dips, short interruptions and voltage variations immunity tests* (IEC 61000-4-11:2004)

EN 61000-6-1:2007, *Electromagnetic compatibility (EMC) - Part 6-1: Generic standards - Immunity for residential, commercial and light-industrial environments* (IEC 61000-6-1:2005)

EN 61000-6-2:2005, *Electromagnetic compatibility (EMC) - Part 6-2: Generic standards - Immunity for industrial environments* (IEC 61000-6-2:2005)

IEC 60050-161:1990, *International Electrotechnical Vocabulary - Chapter 161: Electromagnetic compatibility*<sup>2)</sup>

iTeh STANDARD PREVIEW

### 3 Terms and definitions (standards.iteh.ai)

For the purposes of this document, the terms and definitions given in EN 61000-6-1:2007, EN 61000-6-2:2005, IEC 60050-161:1990 and the following apply.

ISO and IEC maintain terminological databases for use in standardization at the following addresses:

- IEC Electropedia: available at <http://www.electropedia.org/>
- ISO Online browsing platform: available at <http://www.iso.org/obp>

#### 3.1

##### assembly of apparatus

arrangement of interconnected apparatus, which can be tested together

Note 1 to entry: See Figure 1 and Figure 2 as examples.

#### 3.2

##### apparatus

assembly of components with an intrinsic function as defined by its manufacturer

Note 1 to entry: See Figure 1 and Figure 2 as examples.

Note 2 to entry: Safety components listed by Annex IV of the Lifts Directive are considered as apparatus.

1) This document is currently impacted by the amendment EN 61000-4-3:2006/A2:2010.

2) This document is currently impacted by the amendments IEC 60050-161:1990/A1:1997 and IEC 60050-161:1990/A2:1998.

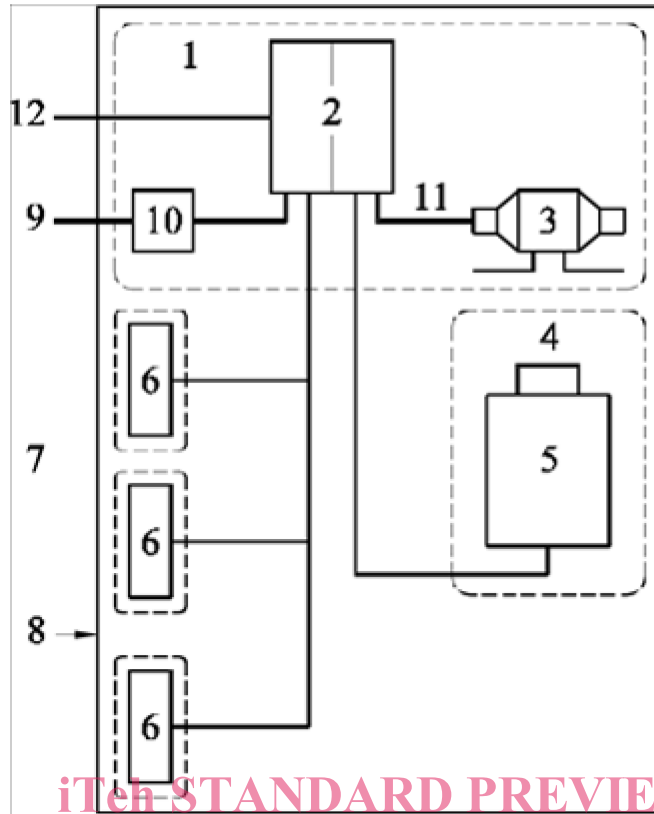

ITCH STANDARD PREVIEW  
(standards.itech.ai)

**Key**



assembly of apparatus

- |   |  |    |   |
|---|--|----|---|
| 1 | machinery space  | 7  | landings                                      |
| 2 | main control / control cabinet                                     | 8  | system boundary                               |
| 3 | machine  | 9  | AC – and/or DC power ports                    |
| 4 | door control   | 10 | main switch                                   |
| 5 | lift car   | 11 | output power port                             |
| 6 | apparatus installed at the landing (e.g. push buttons, indicators) | 12 | ports for monitoring and remote alarm systems |

**Figure 1 — EMC example (immunity) for lift systems**

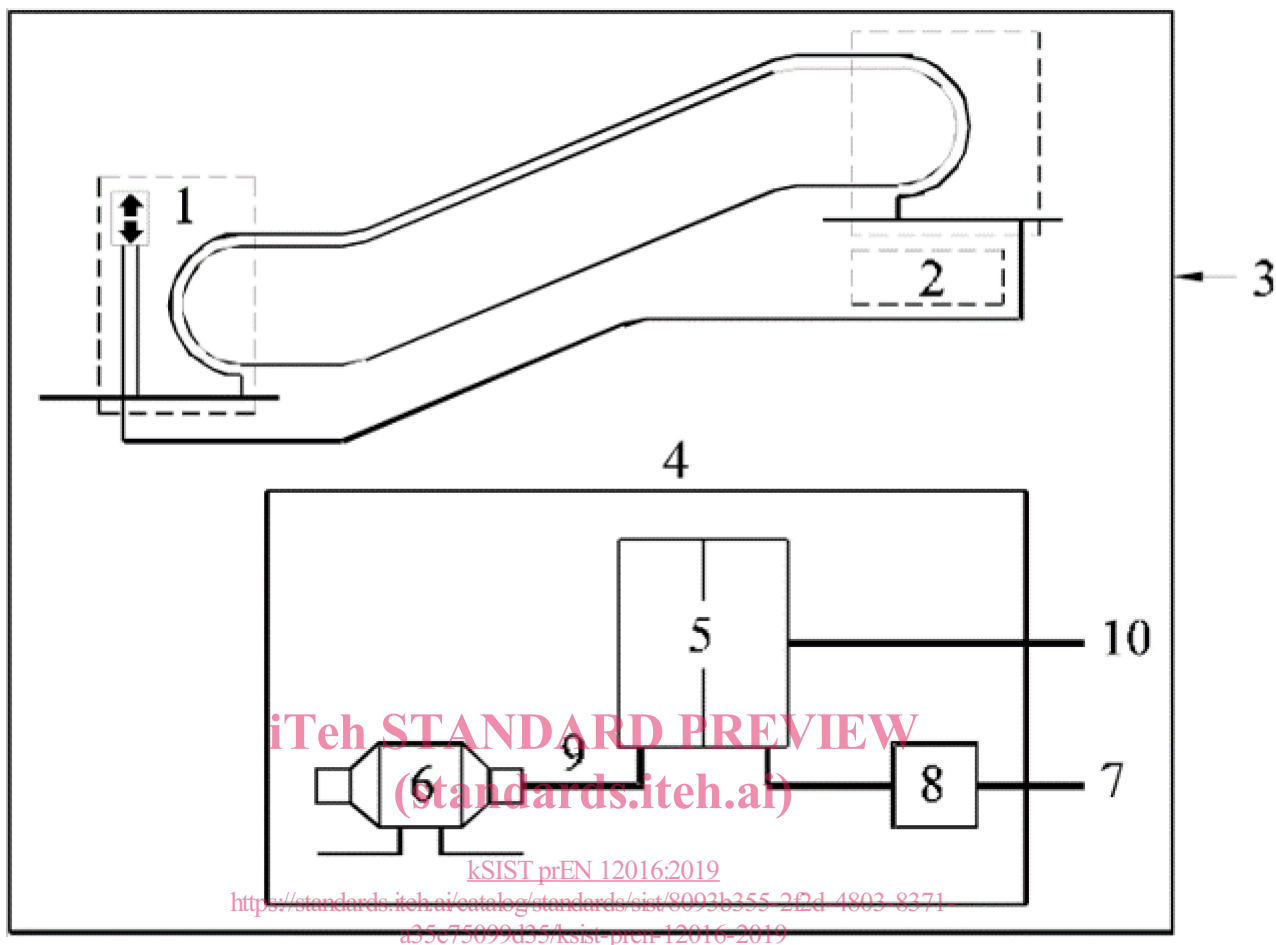
**Key**

 assembly of apparatus

- |   |                               |    |                            |
|---|-------------------------------|----|----------------------------|
| 1 | control panels                | 6  | machine                    |
| 2 | machinery space (see 4 to 10) | 7  | AC - and/or DC power ports |
| 3 | system boundary               | 8  | main switch                |
| 4 | machinery space               | 9  | output power port          |
| 5 | main control/control cabinet  | 10 | ports for monitoring       |

NOTE The machinery space can also be an external room.

**Figure 2 — EMC example (immunity) for escalator and moving walk systems**

**3.3****enclosure port**

physical boundary of apparatus/assembly of apparatus through which electromagnetic fields may radiate or impinge

Note 1 to entry: See Figure 3 as an example.

**3.4****general function circuit**

circuitry used in apparatus which does not incorporate safety circuits

Note 1 to entry: See Figure 1 to Figure 3.