



**SLOVENSKI STANDARD**  
**SIST ISO 1922:2020**

**01-september-2020**

---

**Penjeni polimerni materiali - Ugotavljanje nateznih lastnosti**

Rigid cellular plastics - Determination of shear properties

**iTeh STANDARD PREVIEW**  
**(standards.iteh.ai)**

**Ta slovenski standard je istoveten z: ISO 1922:2018**

[SIST ISO 1922:2020](https://standards.iteh.ai/catalog/standards/sist/7a07e39f-7ad8-4c1c-952e-1ccc24814aa/sist-iso-1922-2020)

<https://standards.iteh.ai/catalog/standards/sist/7a07e39f-7ad8-4c1c-952e-1ccc24814aa/sist-iso-1922-2020>

**ICS:**

83.100

Penjeni polimeri

Cellular materials

**SIST ISO 1922:2020**

**en,fr,de**

**iTeh STANDARD PREVIEW**  
**(standards.iteh.ai)**

SIST ISO 1922:2020

<https://standards.iteh.ai/catalog/standards/sist/7a07e39f-7ad8-4c1c-952e-1cecf24814aa/sist-iso-1922-2020>

INTERNATIONAL  
STANDARD

ISO  
1922

Fifth edition  
2018-09

---

---

**Rigid cellular plastics —  
Determination of shear properties**

**iTeh STANDARD PREVIEW**  
**(standards.iteh.ai)**

[SIST ISO 1922:2020](https://standards.iteh.ai/catalog/standards/sist/7a07e39f-7ad8-4c1c-952e-1cecf24814aa/sist-iso-1922-2020)

<https://standards.iteh.ai/catalog/standards/sist/7a07e39f-7ad8-4c1c-952e-1cecf24814aa/sist-iso-1922-2020>



Reference number  
ISO 1922:2018(E)

© ISO 2018

## iTeh STANDARD PREVIEW (standards.iteh.ai)

SIST ISO 1922:2020

<https://standards.iteh.ai/catalog/standards/sist/7a07e39f-7ad8-4c1c-952e-1cecf24814aa/sist-iso-1922-2020>



### **COPYRIGHT PROTECTED DOCUMENT**

© ISO 2018

All rights reserved. Unless otherwise specified, or required in the context of its implementation, no part of this publication may be reproduced or utilized otherwise in any form or by any means, electronic or mechanical, including photocopying, or posting on the internet or an intranet, without prior written permission. Permission can be requested from either ISO at the address below or ISO's member body in the country of the requester.

ISO copyright office  
CP 401 • Ch. de Blandonnet 8  
CH-1214 Vernier, Geneva  
Phone: +41 22 749 01 11  
Fax: +41 22 749 09 47  
Email: [copyright@iso.org](mailto:copyright@iso.org)  
Website: [www.iso.org](http://www.iso.org)

Published in Switzerland

# Contents

Page

Foreword.....	iv
<b>1 Scope.....</b>	<b>1</b>
<b>2 Normative references.....</b>	<b>1</b>
<b>3 Terms and definitions.....</b>	<b>1</b>
<b>4 Principle.....</b>	<b>1</b>
<b>5 Apparatus.....</b>	<b>1</b>
<b>6 Dimensions of test specimens.....</b>	<b>5</b>
6.1 General.....	5
6.2 Single shear test specimen.....	5
6.3 Double shear test specimen.....	5
<b>7 Number of test specimens.....</b>	<b>5</b>
<b>8 Conditioning and test temperature and humidity.....</b>	<b>6</b>
<b>9 Procedure.....</b>	<b>6</b>
<b>10 Calculation and expression of results.....</b>	<b>7</b>
10.1 Shear strength.....	7
10.2 Shear modulus.....	7
10.3 Shear strain at fracture.....	7
<b>11 Precision and bias.....</b>	<b>8</b>
<b>12 Test report.....</b>	<b>8</b>
<b>Annex A (normative) Choice of adhesives for preparation of test specimens.....</b>	<b>9</b>
<b>Bibliography.....</b>	<b>10</b>

## ISO 1922:2018(E)

## Foreword

ISO (the International Organization for Standardization) is a worldwide federation of national standards bodies (ISO member bodies). The work of preparing International Standards is normally carried out through ISO technical committees. Each member body interested in a subject for which a technical committee has been established has the right to be represented on that committee. International organizations, governmental and non-governmental, in liaison with ISO, also take part in the work. ISO collaborates closely with the International Electrotechnical Commission (IEC) on all matters of electrotechnical standardization.

The procedures used to develop this document and those intended for its further maintenance are described in the ISO/IEC Directives, Part 1. In particular the different approval criteria needed for the different types of ISO documents should be noted. This document was drafted in accordance with the editorial rules of the ISO/IEC Directives, Part 2 (see [www.iso.org/directives](http://www.iso.org/directives)).

Attention is drawn to the possibility that some of the elements of this document may be the subject of patent rights. ISO shall not be held responsible for identifying any or all such patent rights. Details of any patent rights identified during the development of the document will be in the Introduction and/or on the ISO list of patent declarations received (see [www.iso.org/patents](http://www.iso.org/patents)).

Any trade name used in this document is information given for the convenience of users and does not constitute an endorsement.

For an explanation on the voluntary nature of standards, the meaning of ISO specific terms and expressions related to conformity assessment, as well as information about ISO's adherence to the World Trade Organization (WTO) principles in the Technical Barriers to Trade (TBT) see the following URL: [www.iso.org/iso/foreword.html](http://www.iso.org/iso/foreword.html). (standards.iteh.ai)

This document was prepared by Technical Committee ISO/TC 61, *Plastics*, Subcommittee SC 10, *Cellular plastics*.

<https://standards.iteh.ai/catalog/standards/sist/7a07e39f-7ad8-4c1c-952e-146071400000/iso-1922-2018>

This fifth edition cancels and replaces the fourth edition (ISO 1922:2012), which has been technically revised.

The main changes compared to the previous edition are as follows:

- title has been modified as: Rigid cellular plastics — Determination of shear properties;
- [Clauses 2, 4, 5, 7, 8, 9](#) have been technically revised.

Any feedback or questions on this document should be directed to the user's national standards body. A complete listing of these bodies can be found at [www.iso.org/members.html](http://www.iso.org/members.html).

# Rigid cellular plastics — Determination of shear properties

## 1 Scope

This document specifies a procedure of determining the shear strength of rigid cellular plastics. It also provides for the determination of shear modulus and shear strain.

## 2 Normative references

The following documents are referred to in the text in such a way that some or all of their content constitutes requirements of this document. For dated references, only the edition cited applies. For undated references, the latest edition of the referenced document (including any amendments) applies.

ISO 1923, *Cellular plastics and rubbers — Determination of linear dimensions*

ISO 7500-1, *Metallic materials — Calibration and verification of static uniaxial testing machines — Part 1: Tension/compression testing machines — Calibration and verification of the force-measuring system*

## 3 Terms and definitions

No terms and definitions are listed in this document.

ISO and IEC maintain terminological databases for use in standardization at the following addresses:

- ISO Online browsing platform: available at <https://www.iso.org/obp>
- IEC Electropedia: available at <http://www.electropedia.org/>

## 4 Principle

A shear stress is applied to a test specimen of defined shape by means of rigid specimen supports bonded to the specimen.

There are two procedures:

- Procedure A, which is recommended for shear strength measurement only;
- Procedure B, which uses an extensometer or similar device to measure displacement and is, thus, the recommended method to calculate the shear modulus and strain (and strength as well).

## 5 Apparatus

### 5.1 Test machine

#### 5.1.1 General

A test machine capable of applying a sufficient force within the maximum displacement experienced in the shear test.

It shall be capable of operating at a constant rate of movement of the movable head of  $(1 \pm 0,5)$  mm/min in a direction parallel to the longitudinal axis of the test specimen assembly.

## ISO 1922:2018(E)

The test machine, conforming to class 1 of ISO 7500-1 shall exert a force on the test specimen, and produce a displacement of the movable support relative to the fixed supports, having a maximum error of 1 %.

If the shear modulus and strain is required, the force and the displacement shall be simultaneously recorded.

### 5.1.2 Single test specimen arrangement

The test machine shall exert longitudinal shear forces through parallel plates bonded to a single test specimen of dimensions as in 6.2. The parallel plates shall be rigid with one plate attached to the fixed parts and the other to the movable parts of the test machine.

### 5.1.3 Double test specimen arrangement

The test machine shall exert longitudinal shear forces through parallel plates bonded to a double test specimen of dimensions as in 6.3. The parallel plates shall be rigid with the outer plates attached to the fixed parts and the central plate to the movable parts of the test machine.

## 5.2 Specimen supports

### 5.2.1 Single test specimen assembly

Two flat rigid specimen supports with a length 330 mm, a width of 50 mm and a thickness of  $(16 \pm 1)$  mm shall be attached to the grips of the test machine via an adaptor and universal joint.

The procedure of attaching the specimen supports to the grips is shown in Figure 1. The thickness of the adaptors that connect the specimen supports to the test machine grips shall be the same as the thickness of the test specimen.

NOTE Flat, rectangular-sectioned mild steel plates with a thickness of 16 mm have proved to be suitable for the support material.

### 5.2.2 Double test specimen assembly

Three flat rigid specimen supports with a length of 330 mm, a width of 50 mm and a thickness of  $(16 \pm 1)$  mm shall be attached to the grips of the test machine via an adaptor and universal joint.

NOTE The essential features are three flat rigid supports of which two can be maintained with their planes parallel and vertical. A suitable arrangement is shown in Figure 2.

Experience gained using both the single and double test specimen procedures with several products indicated that it is of paramount importance that the specimen supports are very rigid. With the double test specimen arrangement, the fixed support should be maintained in parallel vertical plates, the arrangements shown in Figure 2 have proved suitable.

## 5.3 Measurement of displacement

### 5.3.1 Procedure A

The testing machine shall be fitted with a system allowing continuous measurement of the displacement  $x$  of the movable plate with an accuracy of  $\pm 5$  % or  $\pm 0,1$  mm if this latter value is a more accurate measurement.

Procedure A is not recommended for measuring modulus but for shear strength only.

### 5.3.2 Procedure B

An extensometer or a similar device shall be capable of measuring the displacement between the rigid specimen supports with a precision of at least  $\pm 1$  %.

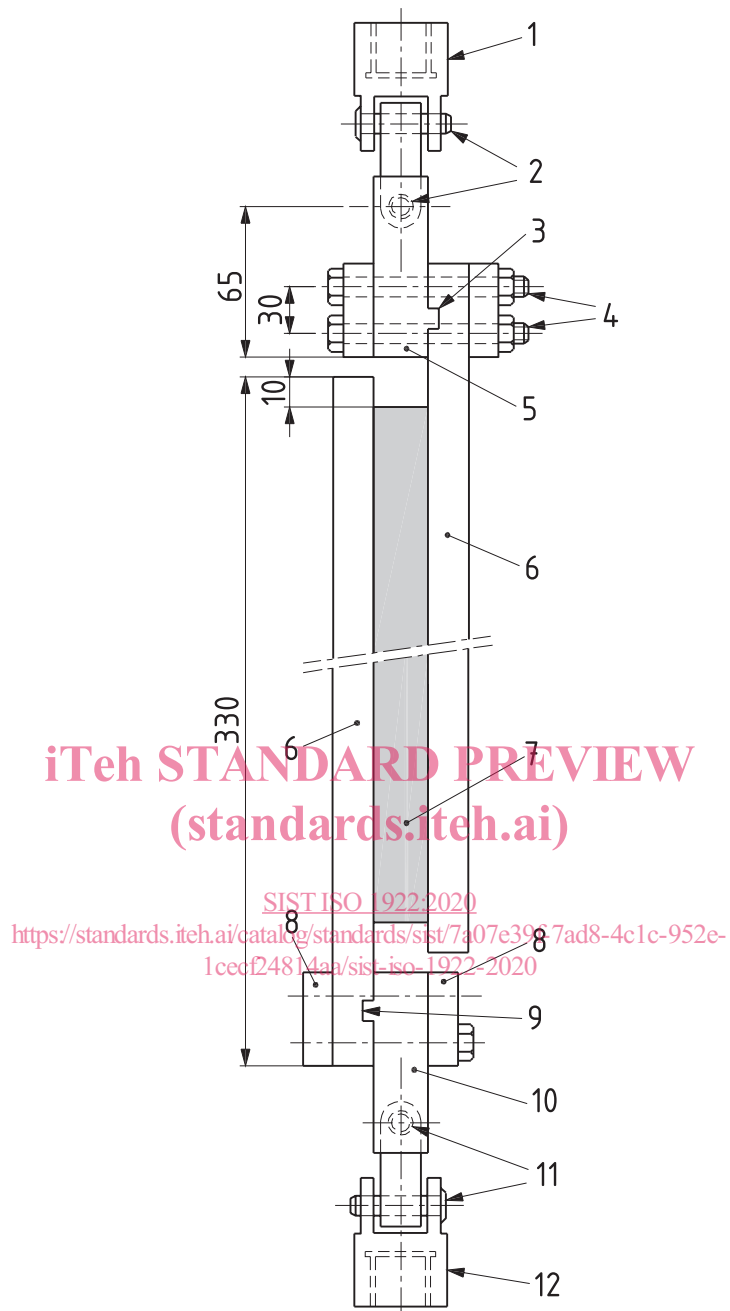

Dimensions in millimetres

**Key**

- |   |  |    |   |
|---|--|----|---|
| 1 | fixed machine grip                                 | 7  | test specimen   |
| 2 | universal joint connection pins, allowing rotation | 8  | load spreading plates measuring (50 × 50 × 5) mm about axis   |
| 3 | tongue and groove                                  | 9  | tongue and groove   |
| 4 | nut and bolt supports, $\varnothing 10$ mm         | 10 | adaptor   |
| 5 | rigid specimen support                             | 11 | universal joint connection pins, allowing rotation about axis |
| 6 | rigid specimen supports                            | 12 | movable machine grip  |

**Figure 1 — Single plate test assembly**