



Standard Test Method for Evaluation of Automotive Engine Oils for Inhibition of Deposit Formation in a Spark-Ignition Internal Combustion Engine Fueled with Gasoline and Operated Under Low- Temperature, Light-Duty Conditions¹

This standard is issued under the fixed designation D 6593; the number immediately following the designation indicates the year of original adoption or, in the case of revision, the year of last revision. A number in parentheses indicates the year of last reapproval. A superscript epsilon (ϵ) indicates an editorial change since the last revision or reapproval.

1. Scope

1.1 This test method covers and is commonly referred to as the Sequence VG test,² and it has been correlated with vehicles used in stop-and-go service prior to 1996, particularly with regard to sludge and varnish formation.³ It is one of the test methods required to evaluate oils intended to satisfy the API SL performance category.

1.2

1.2 The values stated in SI units are to be regarded as the standard. The values in parentheses are for information only.

1.3 This standard does not purport to address all of the safety concerns, if any, associated with its use. It is the responsibility of the user of this standard to establish appropriate safety and health practices and determine the applicability of regulatory limitations prior to use. Specific hazard statements are given in 7.7, 7.10.2.2, 8.3.4.2, 8.4.4.3, 9.2.6, 9.3.4.5, 12.1.1.7, 12.2.1.4, and Annex A1.

1.4 A Table of Contents follows:

	Section
Scope	1
Referenced Documents	2
Terminology	3
Summary of Test Method	4
Significance and Use	5
Apparatus (General Description)	6
Apparatus (The Test Engine)	7
Sequence VG Test Engine	7.1
Required New Engine Parts	7.2
Reusable Engine Parts	7.3
Specially Fabricated Engine Parts	7.4
Special Engine Measurement and Assembly Equipment	7.5
Miscellaneous Engine Components-Preparation	7.6
Solvents and Cleaners Required	7.7
Assembling the Test Engine-Preparations	7.8
Assembling the Test Engine-Installations	7.9
Engine Installation on the Test Stand	7.10
Engine Fluids (Supply/Discharge Systems)	8
Intake Air	8.1
Fuel and Fuel System	8.2
Engine Oil and Engine Oil System	8.3
Coolants	8.4
Measurement Instrumentation	9
Temperatures	9.1
Pressures	9.2
Flow Rates	9.3
Fuel Consumption	9.4
Speed and Load	9.5
Exhaust Gas	9.6

¹ This test method is under the jurisdiction of ASTM Committee D02 on Petroleum Products and Lubricants and is the direct responsibility of Subcommittee D02.B0.01 on Passenger Car Engine Oils.

Current edition approved Nov. 1, 2007-Oct. 15, 2008. Published December 2007-November 2008. Originally approved in 2000. Last previous edition approved in 2007 as D 6593-07a.

² Until the next revision of this test method, the ASTM Test Monitoring Center will update changes in the test method by means of information letters. Information letters may be obtained from the ASTM Test Monitoring Center, 6555 Penn Ave., Pittsburgh, PA 15206-4489. Attention: Administrator. This edition incorporates revisions in all information Letters through No. 06-2-08-2.

³ Supporting data have been filed at ASTM International Headquarters and may be obtained by requesting Research Report RR: D02-1472.

	Humidity	9.7
Miscellaneous Laboratory Equipment		10
Test Stand Calibration		11
Test Procedure		12
	Pre-Test Procedure	12.1
	Engine Operating Procedure	12.2
	Periodic Measurements and Functions	12.3
	Special Maintenance Procedures	12.4
	Diagnostic Data Review	12.5
	End of Test Procedure	12.6
Interpretation of Test Results		13
	Parts Rating Area-Environment	13.1
	Sludge Ratings	13.2
	Varnish Ratings	13.3
	Clogging	13.4
	Sticking	13.5
	Used Oil Analyses	13.6
Assessment of Test Validity		14
	General	14.1
	Used Oil Analyses-Interpretation	14.2
	Blowby Flow Rate	14.3
	Manifold Absolute Pressure	14.4
	Fuel Consumption Rate	14.5
	Oil Consumption	14.6
	Engine Parts Replacement	14.7
	Quality Index and Deviation Percentage	14.8
Final Test Report		15
	Report Forms	15.1
Precision and Bias		16
Keywords		17
ANNEXES		
	Safety Hazards	Annex A1
	Control and Data Acquisition Requirements	Annex A2
	Detailed Specifications and Photographs of Apparatus	Annex A3
	Special Service Tools for the Test Engine	Annex A4
	Test Engine Part Number Listing	Annex A5
	External Oil Heat Exchanger Cleaning Technique	Annex A6
	Sequence VG Report Forms and Data Dictionary	Annex A7
	Dipstick Calibration	Annex A8
	Critical Part Supplier List	Annex A9
	Operational Data Log-Engine Oil	Annex A10
	Rating Worksheets	Annex A11
	Fuel Injector Flow Measurements	Annex A12
APPENDICES		
	Piston and Ring Measurements Record Forms	Appendix X1
	Sources of Materials and Information	Appendix X2
	Description of Scott Quarterly Gas Audit Service	Appendix X3

2. Referenced Documents

2.1 ASTM Standards:⁴

- D 86 Test Method for Distillation of Petroleum Products at Atmospheric Pressure
- D 235 Specification for Mineral Spirits (Petroleum Spirits) (Hydrocarbon Dry Cleaning Solvent)
- D 287 Test Method for API Gravity of Crude Petroleum and Petroleum Products (Hydrometer Method)
- D 323 Test Method for Vapor Pressure of Petroleum Products (Reid Method)
- D 381 Test Method for Gum Content in Fuels by Jet Evaporation
- D 445 Test Method for Kinematic Viscosity of Transparent and Opaque Liquids (and Calculation of Dynamic Viscosity)
- D 525 Test Method for Oxidation Stability of Gasoline (Induction Period Method)
- D 873 Test Method for Oxidation Stability of Aviation Fuels (Potential Residue Method)
- D 1266 Test Method for Sulfur in Petroleum Products (Lamp Method)
- D 1298 Test Method for Density, Relative Density (Specific Gravity), or API Gravity of Crude Petroleum and Liquid Petroleum Products by Hydrometer Method
- D 2622 Test Method for Sulfur in Petroleum Products by Wavelength Dispersive X-ray Fluorescence Spectrometry
- D 2789 Test Method for Hydrocarbon Types in Low Olefinic Gasoline by Mass Spectrometry
- D 3237 Test Method for Lead in Gasoline by Atomic Absorption Spectroscopy
- D 3525 Test Method for Gasoline Diluent in Used Gasoline Engine Oils by Gas Chromatography
- D 4057 Practice for Manual Sampling of Petroleum and Petroleum Products
- D 4175 Terminology Relating to Petroleum, Petroleum Products, and Lubricants

⁴ For referenced ASTM standards, visit the ASTM website, www.astm.org, or contact ASTM Customer Service at service@astm.org. For *Annual Book of ASTM Standards* volume information, refer to the standard's Document Summary page on the ASTM website.

- D 4294 Test Method for Sulfur in Petroleum and Petroleum Products by Energy Dispersive X-ray Fluorescence Spectrometry
- D 4485 Specification for Performance of Engine Oils
- D 4863 Test Method for Determination of Lubricity of Two-Stroke-Cycle Gasoline Engine Lubricants
- D 5059 Test Methods for Lead in Gasoline by X-Ray Spectroscopy
- D 5185 Test Method for Determination of Additive Elements, Wear Metals, and Contaminants in Used Lubricating Oils and Determination of Selected Elements in Base Oils by Inductively Coupled Plasma Atomic Emission Spectrometry (ICP-AES)
- D 5862 Test Method for Evaluation of Engine Oils in Two-Stroke Cycle Turbo-Supercharged 6V92TA Diesel Engine
- D 6304 Test Method for Determination of Water in Petroleum Products, Lubricating Oils, and Additives by Coulometric Karl Fischer Titration
- G 40 Terminology Relating to Wear and Erosion
- 2.2 ANSI Standard:⁵
- ANSI MC96.1 Temperature Measurement-Thermocouples

3. Terminology

3.1 Definitions:

3.1.1 *air-fuel ratio, n*— in internal combustion engines, the mass ratio of air-to-fuel in the mixture being inducted into the combustion chambers.

3.1.1.1 *Discussion*—In this test method, air-fuel ratio (AFR), is controlled by the EEC IV engine control module. **D 4175**

3.1.2 *blowby, n*—in internal combustion engines, the combustion products and unburned air and fuel mixture that enter the crankcase. **D 4175**

3.1.3 *cold-stuck piston ring, n*— in internal combustion engines, a piston ring that is stuck when the piston and ring are at room temperature, but inspection shows that it was free during engine operation.

3.1.3.1 *Discussion*—A cold-stuck piston ring cannot be moved with moderate finger pressure. It is characterized by a polished face over its entire circumference, indicating essentially no blowby passed over the ring face during engine operation. **D 4175**

3.1.4 *debris, n*—in internal combustion engines, solid contaminant materials unintentionally introduced into the engine or resulting from wear.

3.1.4.1 *Discussion*—Examples include such things as gasket material, silicone sealer, towel threads, and metal particles. **D 5862**

3.1.5 *filtering, n*—in data acquisition, a means of attenuating signals in a given frequency range. They can be mechanical (volume tank, spring, mass) or electrical (capacitance, inductance) or digital (mathematical formulas), or a combination thereof. Typically, a low-pass filter attenuates the unwanted high frequency noise.

3.1.6 *hot-stuck piston ring, n*— in internal combustion engines, a piston ring that is stuck when the piston and ring are at room temperature, and inspection shows that it was stuck during engine operation.

3.1.6.1 *Discussion*—The portion of the ring that is stuck cannot be moved with moderate finger pressure. A hot-stuck piston ring is characterized by varnish or carbon across some portion of its face, indicating that portion of the ring was not contacting the cylinder wall during engine operation. **D 4175**

3.1.7 *knock, n*—in a spark ignition engine, abnormal combustion, often producing audible sound, caused by autoignition of the air/fuel mixture. **D 4175**

3.1.8 *out of specification data, n*—in data acquisition, sampled value of a monitored test parameter that has deviated beyond the procedural limits

3.1.9 *reading, n*—in data acquisition, the reduction of data points that represent the operating conditions observed in the time period as defined in the test procedure.

3.1.10 *scoring, n*—in tribology, a severe form of wear characterized by the formation of extensive grooves and scratches in the direction of sliding. **G 40**

3.1.11 *scuffing, n*—in lubrication, damage caused by instantaneous localized welding between surfaces in relative motion that does not result in immobilization of the parts. **D 4863**

3.1.12 *sludge, n*—in internal combustion engines, a deposit, principally composed of insoluble resins and oxidation products from fuel combustion and the lubricant, that does not drain from engine parts but can be removed by wiping with a cloth. **D 4175**

3.1.13 *time constant, n*— in data acquisition, A value which represents a measure of the time response of a system. For a first order system responding to a step change input, it is the time required for the output to reach 63.2 % of its final value.

3.1.14 *varnish, n*—in internal combustion engines, a hard, dry, generally lustrous deposit that can be removed by solvents but not by wiping with a cloth. **D 4175**

3.1.15 *wear, n*—loss of material from, or relocation of material on, a surface.

3.1.15.1 *Discussion*—Wear generally occurs between two surfaces moving relative to each other, and is the result of mechanical or chemical action or by a combination of mechanical and chemical actions. **D 4175**

⁵ Available from American National Standards Institute (ANSI), 25 W. 43rd St., 4th Floor, New York, NY 10036.

3.2 Definitions of Terms Specific to This Standard:

3.2.1 *clogging, n*—the restriction of a flow path due to the accumulation of material along the flow path boundaries.

3.2.2 *enrichment, n*—in internal combustion engine operation, a fuel consumption rate in excess of that which would achieve a stoichiometric air-to-fuel ratio.

3.2.2.1 *Discussion*—Enrichment is usually indicated by elevated CO levels and can also be detected with an extended range air/fuel ratio sensor.

3.2.3 *Lambda, n*—the ratio of actual air mass induced, during engine operation, divided by the theoretical air mass requirement at the stoichiometric air-fuel ratio for the given fuel.

3.2.3.1 *Discussion*—A Lambda value of 1.0 denotes a stoichiometric air-fuel ratio.

3.2.4 *low-temperature, light-duty conditions, n*—indicative of engine oil and coolant temperatures that average below normal warmed-up temperatures, and engine speeds and power outputs that average below those encountered in typical highway driving.

3.2.5 *ramping, n*—the prescribed rate of change of a variable when one set of operating conditions is changed to another set of operating conditions.

4. Summary of Test Method

4.1 Each test engine is assembled with many new parts and essentially all aspects of assembly are specified in detail.

4.2 The test stand is equipped to control speed, load, AFR, and various other operating parameters.

4.3 The test is run for a total of 216 h, consisting of 54 cycles of 4 h each. Each cycle consists of three stages.

4.4 While the operating conditions are varied within each cycle, overall they can be characterized as a mixture of low-temperature and moderate-temperature, light and medium duty operating conditions.

4.5 To accelerate deposit formation, the level of oxides of nitrogen in the blowby and the rate of blowby into the crankcase are significantly increased. The fresh air breathing of the crankcase is eliminated and the oil and coolant temperatures are lowered to induce condensation of water and fuel.

4.6 The performance of the test engine oil is evaluated at the end of the test by dismantling the engine and measuring the level of deposit formation.

5. Significance and Use

5.1 This test method is used to evaluate an automotive engine oil's control of engine deposits under operating conditions deliberately selected to accelerate deposit formation. This test method was correlated with field service data, determined from side-by-side comparisons of two or more oils in police, taxi fleets, and delivery van services. The same field service oils were then used in developing the operating conditions of this test procedure.

5.2 This test method, along with other test methods, defines the minimum performance level of the API Category SL (detailed information about this category is included in Specification D 4485). This test method is also incorporated in automobile manufacturers' factory-fill specifications.

5.3 The basic engine used in this test method is representative of many that are in modern automobiles. This factor, along with the accelerated operating conditions, should be considered when interpreting test results.

6. Apparatus (General Description)

6.1 The test engine is a Ford 4.6L, spark ignition, four stroke, eight-cylinder V configuration engine. Features of this engine include an overhead camshaft, a cross-flow fast-burn cylinder head design, two valves per cylinder and electronic port fuel injection. It is based on the Ford Motor Co. 4.6L EFI Crown Victoria⁶ passenger car engine.

6.2 Configure the test stand to accept a Ford 4.6L two valves per cylinder engine. All special equipment necessary for conducting this test is listed herein.

6.3 Use the appropriate air conditioning apparatus to control the temperature, pressure, and humidity of the intake air.

6.4 Use an appropriate fuel supply system (Fig. 1).

6.5 The control and data acquisition system shall meet the requirements listed in Annex A2.

7. Apparatus (The Test Engine)

7.1 *Sequence VG Test Engine*—The test engine kit is available from the Ford Motor Co. (A9.1). Parts from the engine may be used for as many as four tests. A detailed listing of all parts included in the kit is given in Annex A5.

7.1.1 Non-rated parts can be replaced during the test, provided the reason for replacement was not oil related.

7.2 *Required New Engine Parts*—Use the parts listed in the engine kit (see A5.1). Use a new gasket kit for each test. Obtain cylinder heads from the supplier listed in X2.1.21. Use cams from the kit, polished by the supplier listed in X2.1.11.

7.3 *Reusable Engine Parts*—The parts listed in the test stand set up kit, supplemental stand set up kit, engine dress kit, and engine finish and fastener kit can be reused (all of these can be used in numerous engine assemblies as long as they remain serviceable). See Annex A5. Crankshaft, connecting rods, timing chain covers and cylinder heads may be used for multiple engine assemblies as long as they remain serviceable. Camshafts can be used for as many as four tests as long as they remain serviceable.

⁶ Ford Crown Victoria is a product of the Ford Motor Co., Dearborn, MI 48121.

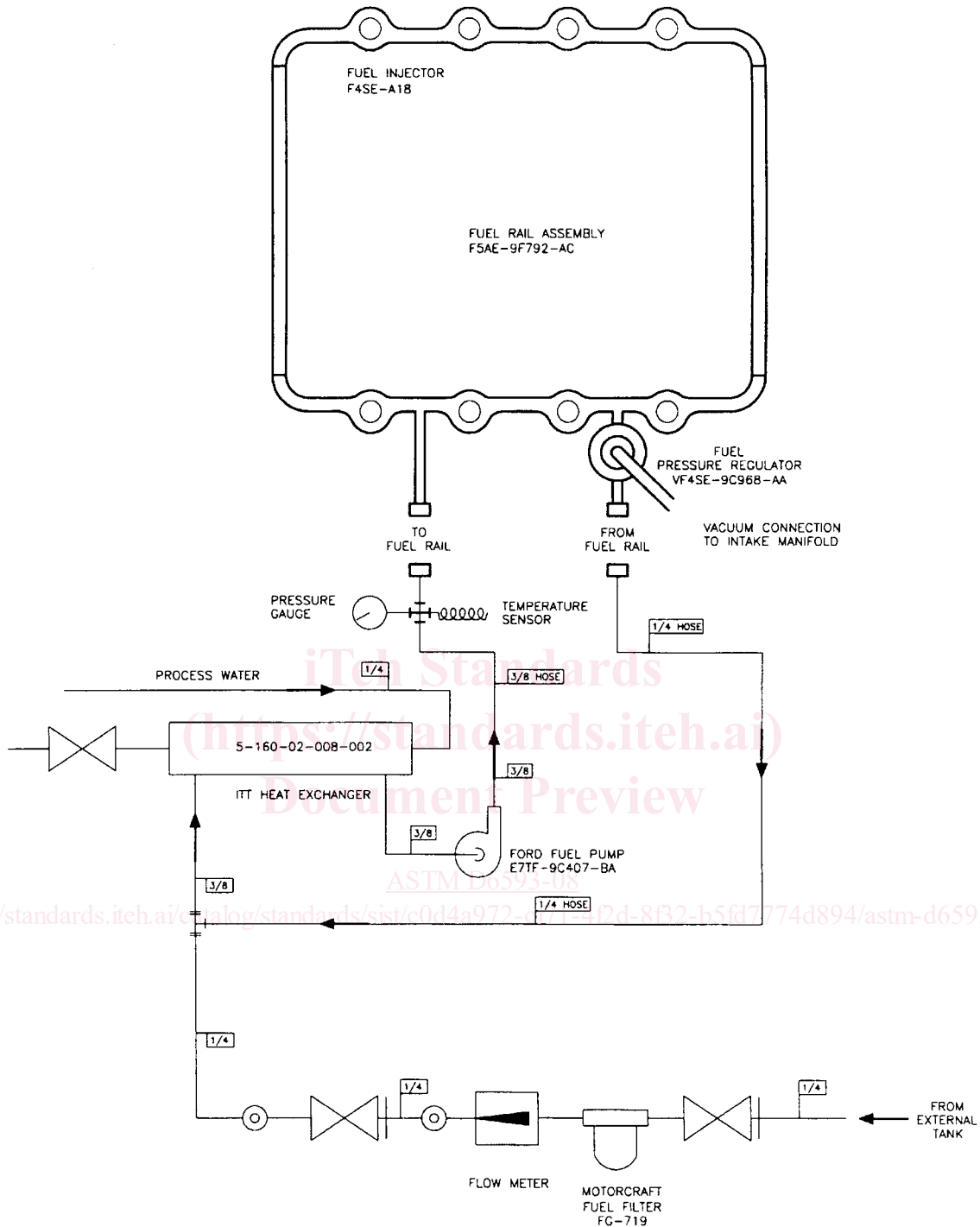

FIG. 1 Schematic of Engine Fuel System

7.4 Specially Fabricated Engine Parts—The following subsections detail the specially fabricated engine parts required in this test method:

7.4.1 Intake Air System (see Fig. 2 and Figs. A3.1 and A3.2)—Intake air system shall use the stock Crown Victoria configuration with the air horn removed from the air cleaner.

7.4.2 Camshaft Baffles (see Fig. A3.3)—These are fabricated for attachment to the under side of the rocker cover. The clearance between the edges of the baffle and the (rocker arm cover) RAC permits a limited splash flow of oil to the top of the baffle and the RAC. Therefore, the dimensional accuracy of the baffle is important to minimize the influence on test severity. The camshaft baffle is available from the supplier listed in A9.2.

7.4.3 Crankcase Oil Fill Port—The crankcase oil fill port is located towards the rear of the left rocker cover. See item 8 and 9 on Fig. A3.4.

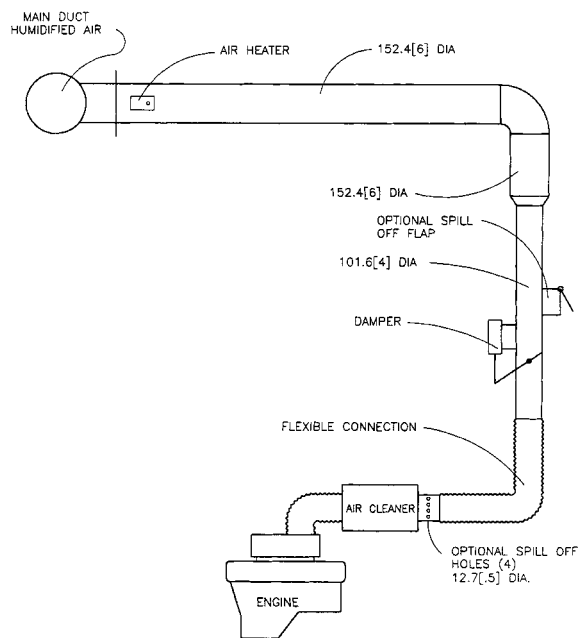

NOTE—Dimensions are in millimetres and (inches).

FIG. 2 Typical Test Stand Intake Air Supply System

7.4.4 *Dipstick and Dipstick Tube* (see Fig. A3.6)—The dipstick has been modified for accurate oil level measurements. The dipstick and dipstick tube are calibrated as a pair. If either part is replaced, then the pair shall be recalibrated. Use the dipstick and dipstick tube available from the supplier listed in A9.2.

7.4.5 *Oil Pan*—Use a modified oil pan with removable baffles as shown in Fig. A3.7 from the supplier listed in A9.2.

7.4.6 *Exhaust Manifold*—The required exhaust manifolds (see A9.4), transition plates (see A9.3) and exhaust system are shown in Figs. A3.15 and A3.16. A heated exhaust gas oxygen (HEGO) sensor is installed in the exhaust system after each exhaust manifold.

7.4.7 *Flywheel*—Use the flywheel listed in Annex A5.

7.4.8 *Rocker Arm Cover (RAC)*—The RAC is fabricated from stainless steel and incorporates a water jacket and bolt bosses for the camshaft baffle (see Figs. A3.3-A3.5). The RAC, bolts, and washers supplier is listed in A9.2.

7.4.9 *Oil Filter*—Use a 60 µm screen type oil filter with a bypass (see Fig. A3.8) available from the supplier listed in X2.1.20.

7.4.10 *Oil Pan Insulation*—The oil pan is covered with a fiberglass insulation to reduce the effects of ambient temperature variations. The insulation supplier is listed in A9.2.

7.5 *Special Engine Measurement and Assembly Equipment*—Items routinely used in laboratory and workshop are not included. Use any special tools or equipment shown in the 1994 and 2000 Crown Victoria Service Manual⁷ for assembly. A list of these tools is shown in Annex A4. Complete any assembly instructions not detailed in Section 7 according to the instructions in the 1994 and 2000 Crown Victoria Service Manual.

7.5.1 *Piston Ring Positioner*—Use the piston ring positioner to locate the piston rings 28.5 mm (1.125 in.) from the cylinder block deck surface. This allows the compression rings to be positioned in a consistent location in the cylinder bore before measurement. Fabricate the positioner according to the details shown in Fig. A3.9.

7.5.2 *Piston Ring Grinder*—A ring grinder is required for adjusting ring gaps. A suitable ring grinder is noted in 7.8.5.1.

7.5.3 *PCV Valve Flow Rate Device* :

7.5.3.1 Use this device to verify the flow rate of the PCV valve before the test and measure the degree of clogging after the test. Fabricate the device according to the details shown in Fig. A3.10. The device shall have a full scale accuracy of 5 % and a resolution of 0.05 L/s (0.1 ft³/min) (see 7.6.7).

7.5.3.2 Calibrate the flow rate device once every six months against a standard traceable to NIST.

7.5.4 *Engine Service Tools*—A complete list of special tools for the test engine is shown in Annex A4. The tools are available from a Ford dealership. These are designed to aid in performing several service items, in addition to the following specific service items that require special tools to perform the functions indicated (if not self-explanatory).

7.5.5 A total of four master bores are required for verifying the cylinder bore measurement device, for determining ring gap increase for the rings in cylinders 1 and 8, and for determining piston to bore clearance. Master bores are sized according to piston oversize as follows:

⁷ Available from Ford and Lincoln-Mercury Dealerships.

For 0.125 mm piston	90.345 mm
For 0.25 mm piston	90.470 mm
For 0.375 mm piston	90.595 mm
For 0.50 mm piston	90.700 mm

7.5.5.1 Maintain the master bores in a temperature controlled room.

7.5.6 *Oil Screen Blowdown Device*—Use the device available from the supplier listed in A9.3 to blow a controlled amount of compressed air across the oil screen to remove any oil that is retained on the oil screen after allowing it to drain.

7.5.7 *Engine Parts Cleaning*—Clean the engine block and cylinder heads using Model Number 300 LX-P-2x dishwasher type parts cleaning machine or similar apparatus. See X2.1.12.

7.5.8 *Cylinder Hone*—Use a Sunnen CV-616 for cylinder bore resizing and finishing.^{8,9}

7.5.9 *Connecting Rod Heater*—The piston pins are fixed to the connecting rods with an interference fit. A connecting rod heater^{8,10} is required to facilitate installation of the piston pins and prevent piston distortion.

7.6 *Miscellaneous Engine Components-Preparation* :

7.6.1 *Engine Build-Up and Measurement Area-Environment*—The ambient atmosphere of the engine buildup and measurement areas shall be reasonably free of contaminants. A relatively constant temperature (within $\pm 3^{\circ}\text{C}$) is necessary to ensure acceptable repeatability in the measurement of parts dimensions. Maintain the relative humidity at a nominal maximum of 50 % to prevent moisture forming on cold engine parts that are brought into the buildup or measurement areas.

7.6.2 *Intake Manifold and Throttle Body*:

7.6.2.1 The required intake manifold modifications entail blocking off the EGR port (block off plate shown in Fig. A3.11) and the coolant bypass port. Block coolant bypass port in intake manifold by tapping the hole and installing a ½ in. NPT pipe plug. Replace the idle air bypass motor with the idle load control system. A schematic of the system and the idle air block off plate are shown in Fig. A3.12 and Fig. A3.13, respectively.

7.6.2.2 Clean the butterfly and bore of the throttle body with solvent (7.7.1) and air-dry before each test. Do not disassemble the throttle body as this will cause excessive wear on the components. The idle air screw can be removed for the cleaning process. Fully close the idle air screw during test operation.

7.6.2.3 There is no specific life for the throttle body. However, the clearance between the bore and the butterfly will eventually increase and render the body unserviceable. When the clearance becomes too great to allow control of speed, load, and air-fuel ratio during Stage III, discard the throttle body.

7.6.2.4 If throttle assembly F8ZU-9E926-AD is used, perform the following modifications:

(1) Remove the throttle position sensor from the throttle assembly, retaining the two attaching screws.

(2) Install throttle position sensor with part number F2AF-9B989-AA.

(3) Close the bleed air hole by either soldering shut or filling with an epoxy.

7.6.3 *Rocker Arm Cover*:

7.6.3.1 Before each test, inspect the coolant jacket. If a deposit or film is present, then clean the RAC coolant jacket with a commercially available de-scaling cleaner, neutralizer, and inhibitor (8.4.4.1). An example of an acceptable cleaner is detailed in 7.7.3.

7.6.3.2 Submerge the RAC in agitated organic solvent (see 7.7.2) until clean (approximately 1 h). Rinse the parts thoroughly with hot water ($> 60^{\circ}\text{C}$). Rinse the RAC with degreasing solvent (7.7.1) and allow to air-dry. Inspect the appearance of the inside of the RAC. If the before test rating is less than ten on the CRC varnish rating scale (Manual 20),¹¹ polish the RAC with Scotch Brite General Purpose Hand Pad #7447^{8,12} to achieve a dull finish. Rinse with degreasing solvent (7.7.1) and allow to air-dry before use.

7.6.4 *Camshaft Baffle*—Submerge the camshaft baffles in agitated organic solvent (see 7.7.2) until clean (approximately 1 h). Rinse the parts thoroughly with hot water ($> 60^{\circ}\text{C}$). Rinse the camshaft baffles with degreasing solvent (7.7.1) and allow to air-dry. Inspect the appearance of the top surface of the camshaft baffle. If the before test rating is less than ten on the CRC varnish rating scale (Manual 20), polish the camshaft baffle with ~~No. 0 fine steel wool~~ Scotch Brite General Purpose Hand Pad #7447^{8,12} to achieve a dull finish. Rinse with degreasing solvent (7.7.1) and allow to air-dry before use.

7.6.5 *Oil Pan*—Submerge the oil pan in agitated organic solvent (see 7.7.2) until clean (approximately 1 h). Rinse the part thoroughly with hot water ($> 60^{\circ}\text{C}$). Rinse the oil pan with degreasing solvent (7.7.1) and allow to air-dry.

7.6.6 *Oil Pan Baffle*—Submerge the oil pan baffle in agitated organic solvent (see 7.7.2) until clean (approximately 1 h). Rinse the part thoroughly with hot water ($> 60^{\circ}\text{C}$). Rinse the oil pan baffle with degreasing solvent (7.7.1) and allow to air-dry.

⁸ If you are aware of alternative suppliers, please provide this information to ASTM International Headquarters. Your comments will receive careful consideration at a meeting of the responsible technical committee, which you may attend.

⁹ The sole source of supply of the Sunnen CV-616 honing machine known to the committee at this time is Sunnen Inc., 7910 Manchester, St. Louis, MO 63143.

¹⁰ The sole source of supply of the connecting rod heater (Sunnen Model CRH-50) and pin installation tool known to the committee at this time is Sunnen, Inc., 7910 Manchester, St. Louis, MO 63143.

¹¹ The sole source of supply of Penmul L460 known to the committee at this time is Penetone Corp., P.O. Box 22006, Los Angeles, CA 90022.

¹² Available from Coordinating Research Council, Inc., 219 Perimeter Ctr. Pkwy, Atlanta, GA 30346.

¹² The sole source of supply of Dearsol T34 Acidic Cleaner known to the committee at this time is Dearborn Div., subsidiary of W. R. Grace and Co., 300 Genesee St., Lake Zurich, IL 60047.

¹² Scotch Brite is a trademark of 3M Corporate Headquarters, 3M Center, St. Paul, MN 55144-1000.

7.6.7 *PCV Valve*—Measure and record the flow rates of the PCV valve with the calibrated flow device described in 7.5.3 and Fig. A3.10. Measure the flow rate at 25 and 60 kPa vacuum. Because of the hysteresis in the PCV valve spring, make the vacuum adjustments in one direction only. Measure the flow rate twice and average the readings. Reject any PCV valve that does not exhibit an average flow rate of 90 to 140 L/min at 25 kPa and 30 to 50 L/min at 60 kPa.

7.6.8 *Water Pump Drive System*—Use only the pulleys provided in the Sequence VG test stand set-up kit (see Annex A5), crankshaft, water pump, grooved idler and tensioner, and a 956 mm (37 5/8 in.) long five or six groove belt to ensure that the water pump rotates at the proper speed and direction.

7.6.9 *Engine Coolant Temperature Sensor*—Modify engine coolant temperature sensor by attaching a relay and a 13K Ω resistor between the ECT sensor and the EEC as shown in Fig. A3.14.

7.6.10 *Front Cover*—Modify front cover to facilitate installation of tensioner, idler, and water pump drive belt. Since the belt is routed differently from the stock location some bolt bosses may need to be altered to clear the shorter belt and the tensioner. These bolt bosses are used to attach the front end accessory drive components that are not used for this test.

7.6.11 *Oil Separators*—Clean with degreasing solvent (7.7.1) and allow to air-dry.

7.6.12 *Timing Chain Cover*—Submerge the timing chain cover in agitated organic solvent (see 7.7.2) until clean (approximately 1 h). Rinse the part thoroughly with hot water (> 60°C). Clean with degreasing solvent (7.7.1) and allow to air-dry.

7.7 *Solvents and Cleaners Required*—No substitutions for 7.7.1-7.7.5 are allowed. (**Warning**—Use adequate safety provisions with all solvents and cleaners. See Annex A1.)

7.7.1 *Solvent*—Use only mineral spirits meeting the requirements of Specification D 235, Type II, Class C for Aromatic Content (0-2% vol), Flash Point (142°F/61°C, min) and Color (not darker than +25 on Saybolt Scale or 25 on Pt-Co Scale). (**Warning**—Combustible. Health hazard.) Obtain a Certificate of Analysis for each batch of solvent from the supplier.

7.7.2 *Organic Solvent*, Penmul L460. (**Warning**—Combustible. Health hazard.)^{8,13}

7.7.3 *Dearsol 134 Acidic Cleaner*^{8,14} with Inhibitor, RAC cooling jacket internal cleaner. (**Warning**—Combustible. Health hazard.)

7.7.4 *Cooling System Cleaner*, Dupont or equivalent, for cleaning cooling system components external to the engine. (**Warning**—Caustic. Health hazard.)

7.7.5 *Parts Cleaning Soap*,^{8,15} NAT-50 or PDN-50 have been found to be acceptable. (**Warning**—Health hazard.)

7.8 *Assembling the Test Engine-Preparations*—Use the test engine obtained from the supplier in 7.1. If this is the first test on a new engine, disassemble the engine in accordance with the 1994 and 2000 Crown Victoria Shop Manuals. Number the connecting rod bearing caps to the corresponding cylinders. Retain the following parts from the new engine: oil pump, main bearings, connecting rod bearings, thrust washer, oil screen spacer, oil filter gasket, oil pan gasket, exhaust manifold gasket, roller followers, valve lash adjusters, rear seal housing, crankshaft gear, timing chains, tensioners, chain rails, plus the following parts that can be used for multiple tests: cylinder block, crankshaft, connecting rods, ignition ring sensor, crankshaft and camshaft timing sensors, crankshaft vibration damper, crankshaft bolt and washer, oil filter adapter and the water pump and pulley.

7.8.1 *Parts Selection*—Instructions concerning the use of new or used parts are detailed in 7.1.1, 7.2, and 7.3.

7.8.2 *Sealing Compounds*—Use a silicon-based sealer as needed between the rear seal housing-cylinder block, the cylinder block-cylinder head-front cover interfaces, cylinder head-front cover-rocker cover interfaces, and cylinder block-front cover-oil pan interfaces.

7.8.2.1 Use silicon-based sealer sparingly since it can elevate the indicated silicon content of the used oil.

NOTE 1—Non-silicon liquid or tape thread sealers can be used on bolts and plugs.

7.8.3 *Gaskets and Seals*—Install new gaskets and seals during engine assembly.

7.8.4 *Block Preparations*—Inspect block, including oil galleries for debris and rust. Remove any debris or rust that is found. Remove oil gallery plugs. Removal of coolant jacket plugs is left to the discretion of the laboratory. Enlarge the chamfers around the top of the cylinder bore. Spray the block with degreasing solvent (see 7.7.1). Spray block with a 50/50 mixture of degreasing solvent (see 7.7.1) and EF-411.^{8,16} Install the stress plates with cylinder heads and torque to 37 to 43 N·m with an additional 180° in two 90° rotation increments. Head bolts may be used for a maximum of five times. Install the main bearing caps and torque to 40 N·m, with an additional 90° rotation. Install the jackscrews and torque to 8 to 11 N·m.

7.8.4.1 *Honing*:

⁸ The sole source of supply of the soap (NAT-50 or PDN-50) known to the committee at this time is Better Engineering Manufacturing, 8361 Town Court, Baltimore, MD 21236.

¹³ The sole source of supply of Penmul L460 known to the committee at this time is Penetone Corp., P.O. Box 22006, Los Angeles, CA 90022.

¹⁴ The sole source of supply of Mobil EF-411 oil known to the committee at this time is Mobil Oil Corp., 3225 Gallows, Fairfax, VA 22037.

¹⁴ The sole source of supply of Dearsol 134 Acidic Cleaner known to the committee at this time is Dearborn Div., subsidiary of W. R. Grace and Co., 300 Genesee St., Lake Zurich, IL 60047.

¹⁵ The sole source of supply of Scotch Brite 7445 known to the committee at this time is 3M Abrasive Systems Division, 3M Center, Building 223-6N-01, St. Paul, MN 55144-1000.

¹⁵ The sole source of supply of the soap (NAT-50 or PDN-50) known to the committee at this time is Better Engineering Manufacturing, 8361 Town Court, Baltimore, MD 21236.

¹⁶ The sole source of supply of the Sanford Piston Ring Grinder known to the committee at this time is Sanford Mfg. Co., 300 Cox St., P.O. Box 318, Roselle, NJ 07203.

¹⁶ The sole source of supply of Mobil EF-411 oil known to the committee at this time is Mobil Oil Corp., 3225 Gallows, Fairfax, VA 22037.

(1) Install the block in the honing machine. Use a Sunnen CV-616 honing machine to hone the block. Install the block with the right cylinder bank on the outside and the front of the block to the right. Verify the honing oil has been changed within the past 15 h, and change if necessary.

(2) Set the honing machine to flow Sunnen LP8X fluid at a nominal rate of 7 L/min. Set the feed rate to 4 with 57 strokes per minute and spindle speed of 170 r/min. Set the stroke for 5.250 in. and lower the block for 10 mm overstroke.

(3) Install EHU512 stones. Typical pressures of 25 to 40 units have found to be acceptable. Hone the right bank in the following order, cylinder 1, 3, 4 and 2. Hone the left bank in the following order, Cylinder 7, 5, 8 and 6. Following this order will minimize the possibility of over heating one area of the block. The block may be rotated in the honing machine and does not have to be removed to hone the other bank.

(4) Install JHU725 stones and hone for approximately five strokes at 20 to 25 units of pressure in the order described in 7.8.4.1(3).

(5) Install a plateau hone brush and hone at 25 to 30 units of pressure to obtain a surface finish of 8 to 13 μm . Typically 45 strokes have provided acceptable results.

(6) Measure the cylinder bore using a bore ladder shown in Fig. A3.28. Measure bore both longitudinally and transversely. Determine the bore diameter for piston clearance purposes by adding the middle and bottom transverse bore measurements and dividing by two. Measure the piston skirt 42 mm from the top of the piston. Subtract this value from the bore measurement and verify that the piston-to-bore clearance is within 0.020 to 0.046 mm. Re-hone the block or choose a different diameter piston to obtain this clearance.

(7) Determine bore taper by measuring the difference between top-to-bottom, top-to-middle and middle-to-bottom, transversely. Record the maximum value of the readings. Verify that the maximum taper does not exceed 0.006 mm. Determine out-of-round by subtracting the difference between the transverse and longitudinal bore measurements at the top, middle and bottom. Record the maximum value. Verify that the cylinder bore out-of-round does not exceed 0.020 mm.

7.8.4.2 Post Honing Cleaning:

(1) Remove the block from the honing machine. Remove the stress plates, jackscrews, main bearing bolts and caps. Remove jackscrews from the main bearing caps.

(2) Clean with degreasing solvent (see 7.7.1).

(3) Place block in dishwasher type cleaning machine (see 7.5.7) and wash using soap (7.7.5) for 30 min at 60°C.

(4) Spray block with 50/50 solution of EF-411 and degreasing solvent (see 7.7.1).

7.8.4.3 Crankshaft Installation:

(1) If the crankshaft has been used previously, soak the crankshaft in organic solvent (see 7.7.2) for a minimum of 24 h.

(2) Spray the crankshaft with degreasing solvent.

(3) Measure the main journals and verify that the diameters are 67.483 to 67.503 mm.

(4) Measure the connecting rods journals and verify that the diameters are 52.988 to 53.003 mm.

(5) Install the main bearings.

(6) Install the main bearing caps and torque to 40 N·m, with an additional 90° rotation.

(7) Install the jack screws and torque to 9 to 11 N·m.

(8) Install the jack screw bolts and torque to 19 to 23 N·m.

7.8.4.4 Piston Installation:

(1) Examine the skirt surfaces for discoloration. Remove any discoloration by rubbing the piston with a Scotch Brite #7445 pad.^{8, 12} Reject any pistons from which staining cannot be removed.

(2) Install the piston on the connecting rod using Sunnen Model CRH-50 connecting rod heater.^{8, 10}

7.8.5 Piston Rings:

7.8.5.1 Ring Gap Adjustment:

(1) Cut the top and second compression ring gaps as required to obtain the specified blowby flow rate, using the Sanford Piston Ring Grinder.^{8, 17} Record the ring side clearance(s) and new ring gap(s) on any ring(s) adjusted. Enter the new dimension(s) on the Supplemental Operational Data sheets. Typical forms for recording these dimensions are shown in Appendix X1. Ensure that the required ring gap delta and ring side clearance are attained (Table 1). Replace rings if smaller ring gaps are required. Measure the rings for cylinders 1 and 8 in the master bore. These measurements are required to determine the ring gap increase.

(2) Using the master bore, measure the ring gaps for the top rings in cylinders 1 and 8 prior to the start of the test.

7.8.5.2 Piston Ring Cutting Procedure :

¹⁷ The sole source of supply of the 3/16 in. carbide ring cutting burr, No. 74010020 known to the committee at this time is M. A. Ford.

¹⁷ The sole source of supply of the Sanford Piston Ring Grinder known to the committee at this time is Sanford Mfg. Co., 300 Cox St., P.O. Box 318, Roselle, NJ 07203.

TABLE 1 Required Piston and Piston Ring Dimensions

Ring side clearance, avg	0.0508–0.1016 mm (0.0020–0.0040 in.)
Ring gap delta	0.045–0.055 mm (0.0018–0.0022 in.)

(1) Cut the ring to the required gap using the ring cutting burr^{8,18} rotated at a rated speed of 3450 r/min. Remove equal amounts from both sides of the gap. Make final cuts on the down stroke only. The ring is cut with a maximum increment of 0.125 mm until the desired ring gap is achieved.

(2) After the rings are cut remove the ring from the cutting tool, debur using a Sunnen soft stone^{8,19} and wipe with a dry towel.

7.8.5.3 Installation:

(1) Install the oil control rings and the compression rings on the pistons with the gaps located over the piston pin. Position the gaps at approximately 180° intervals, with the top compression ring gap toward the rear. Install the rings using a ring spreader tool, keeping the rings' surfaces parallel to the ring groove in the piston.

(2) If any rings require replacement, then measure and record the new ring gap(s) and ring side clearance(s). Calculate ring side clearance by determining the difference between the ring groove width and the associated ring width.

7.8.6 *Cylinder Bore Measurements* —Measure the cylinder 1 and 8 cylinder bores with the bearing caps in place. Clean the bores with a dry rag. The bores shall be clean and dry when they are measured. Use a bore gage micrometer to determine the diameter of cylinder 1 and 8 at the top, middle and bottom of the second ring travel in the transverse direction.

7.9 *Assembling the Test Engine-Installations* —Assemble the engine according to the instructions in the service manual unless specified herein.

7.9.1 *Intake Manifold*— Block the coolant bypass port in the intake manifold at the thermostat housing (7.6.2.1).

7.9.2 *Piston Installation*—Install pistons in proper cylinders, taking care to ensure rings are not damaged during installation. Wipe the cylinders with EF-411. Install the pistons and connecting rods with the notches facing the rear. Install the rod bearing caps and torque to 40 to 45 N·m with an additional 90° rotation.

7.9.3 *Oil System Components*—All oil system components in the engine are production configuration with the exception of the oil pan which contains removable baffles.

7.9.4 *Cylinder Head Installation* —Cylinder heads are obtained from the supplier in A9.3. Heads may be used for multiple tests, as long as they remain serviceable.

(1) Disassemble heads and inspect for any debris or other deleterious materials and remove as necessary.

(2) If the cylinder heads have not been previously used, spray the cylinder heads with degreasing solvent (see 7.7.1). If the cylinder heads have been used previously, soak in organic solvent (see 7.7.2) for 24 h, place the cylinder heads in the dishwasher type cleaning machine (7.5.7) using soap (7.7.5) at 60°C for 30 min. Promptly remove the cylinder head from the cleaning machine and spray with a 50/50 mixture of EF-411 and degreasing solvent (7.7.1).

(3) Determine valve guide clearance at the top and middle of the heads on the transverse side of the guide. Reject any heads which exceed 0.020 to 0.069 mm for intake and 0.046 to 0.095 mm for exhaust.

(4) Assemble the cylinder heads in accordance with the manual. Verify valves are properly seated. The method is left at the discretion of the laboratory.

(5) Install cam bearings. Camshafts may be installed at this time.

7.9.5 *Camshaft and Related Components* —The camshafts used in this test are for a Ford 4.6L truck engine application and will be different than what is shown in the service manual. The camshaft sprocket is an integral part of the camshaft. Install the camshaft in the same manner as described in the service manual with the exception of the sprocket installation.

7.9.5.1 Prior to the timing chain installation, clock the crankshaft keyway at 315° of crankshaft angle (TDC of piston No. 1) as described in the service manual.⁷ Rotate the crankshaft clockwise only, when viewed from the front.

7.9.5.2 When viewed from the rear, maintain the camshaft D-slot shall at a 90° clocked position relative to the cam cover rail.

7.9.5.3 When installing the timing chains ensure that the timing marks (mentioned above) remain aligned. Install L.H. crankshaft sprocket with timing chain on the crankshaft. Drape the L.H. timing chain over camshaft sprocket. The timing chain shall hang below the tensioner dowel.

7.9.5.4 Repeat the procedure in 7.9.5.3 for the right hand timing chain. After installation, the timing chain shall hang between the chain guide and the tensioner dowel.

NOTE 2—There should be a minimum of chain slack on the tension side between the two sprockets.

7.9.6 *Rocker Arm Cover and Baffle* —Fasten the camshaft baffle to the rocker cover. Cut off the tabs from the rocker cover gasket and install it in the gasket groove on cover rail. Install rocker arm cover on the cylinder head and confirm that the baffle does not contact any valve train components. Using new rubber washers on the bolts, torque the bolts to 8 to 12 N·m (the rubber washers are not reusable). The two rocker covers are different, ensure that the correct cover is installed on the correct head (Figs. A3.4 and A3.5).

7.9.7 *Oil Pan, Baffles, and Insulation* —Install front and rear oil pan baffles to the oil pan as shown in Fig. A3.7. Install front baffle first. Install the oil pan according to the procedure in the service manual. Install the oil pan insulation over the oil pan.

7.9.8 *Water Pump, Water Pump Drive* —Install the water pump and pulley, the crankshaft pulley, and the idler and tensioner

¹⁸ The sole source of supply of Sunnen soft stone, No. JHU-820 known to the committee at this time is Sunnen, Inc., 7910 Manchester, St. Louis, MO 63143.

¹⁸ The sole source of supply of the 3/16 in. carbide ring cutting burr, No. 74010020 known to the committee at this time is M. A. Ford.

¹⁹ The sole source of supply of Pencool 2000 coolant known to the committee at this time is Penray Cos., Inc., 1801 Estes Ave., Elk Grove, IL 60007.

¹⁹ The sole source of supply of Sunnen soft stone, No. JHU-820 known to the committee at this time is Sunnen, Inc., 7910 Manchester, St. Louis, MO 63143.

according to the service manual. These are the only components needed to drive the water pump. All other production front end accessory drive components can be discarded. Pull back tensioner and install water pump drive belt as shown in Fig. 3. Ensure that there is a minimum contact angle of 20° between the drive belt and the water pump pulley.

7.10 *Engine Installation on the Test Stand*—Functions that are to be performed in a specific manner or at a specific time in the assembly process are noted.

7.10.1 *Mounting the Engine on the Test Stand*—Mount the engine on the test stand so that the flywheel friction face is $4.0 \pm 0.5^\circ$ from vertical, with the front of the engine higher than the rear. The engine mounting system should be designed to minimize engine vibration at 700 to 2900 r/min. Couple the engine directly to the dynamometer through a driveshaft. The engine cannot be used to drive any external engine accessory other than the water pump.

7.10.2 *Exhaust System and Gas Sampling Fittings*:

7.10.2.1 The required exhaust manifold, a typical exhaust system, and fittings for exhaust gas sampling are illustrated in Figs. A3.15 and A3.16. Exhaust components should be constructed of either solid or bellows pipe/tubing. Other type flexible pipe is not acceptable.

7.10.2.2 The exhaust gas sample probes can be used until they become unserviceable. If the existing probes are not cracked, brittle, or deformed, clean the outer surface and clear all port holes. Check the probes for possible internal obstruction and reinstall the probes in the exhaust pipe. Stainless steel probes are generally serviceable for several tests; mild steel probes tend to become brittle after one test. Exhaust gas is noxious. (**Warning**—Any leaks in the connections to the sample probe will result in erroneous readings and incorrect air-fuel ratio adjustment.)

7.10.3 *Oil Dipstick and Tube*—Install modified oil dipstick and dipstick tube, described in 7.4.4, in the engine block at the production location and attachment points.

NOTE 3—The intake manifold, the rocker arm covers, and the exhaust manifolds can be installed after the engine is installed on the test stand.

7.10.4 *Fuel Management System*:

7.10.4.1 *Fuel Rail Injectors*:

(1) The fuel injectors may be used for multiple tests providing they meet the requirements delineated in Annex A12. Fuel injectors that have caused misfires in previous tests should be cleaned before reuse. Commercial injector cleaning fluids and flow benches are available from various manufacturers. *Do not use injector cleaning fluids while operating the engine.*

(2) Inspect the O-rings to ensure they are in good condition and will not allow fuel leaks. Install the fuel injectors into the fuel rail and into the intake manifold.

7.10.4.2 *Electronic Engine Control (EEC) System*—The fuel injector operation, cylinder firing, pulse width, ignition timing, and so forth, are controlled by the specified EEC. The EEC module is available from the supplier listed in A9.2.

(1) The EEC power shall come from a battery (13.5 ± 1.5 V) or a power supply that does not interrupt/interfere with proper EEC operation. Connect the EEC battery/power supply to the engine wire harness with an appropriate gage wire of the shortest practical length so as to maintain 12 to 15 V DC on the STAR tester and minimize EEC electrical noise problems. Ground the EEC ground wire to the engine. From the same ground point, run a minimum two gage wire back to the battery negative to prevent interruption/interference of the EEC operation. The power supply can also be used for the Lambda measuring devices.

7.10.5 *Spark Plugs*—Install new Motorcraft AWSF-32PP spark plugs that have been gapped to 1.37 mm (0.054 in.) Torque the spark plugs to 9-12 N·m. Install the spark plug wiring harness. Do not use anti-seize compounds on spark plug threads.

NOTE 4—The components used in the ignition system do not require modification.

7.10.6 *Crankcase Ventilation System* —The crankcase ventilation system is a closed system allowing blowby to be vented from the crankcase and drawn into the intake manifold. A description of the system operation is shown in Fig. 4. Install PCV system

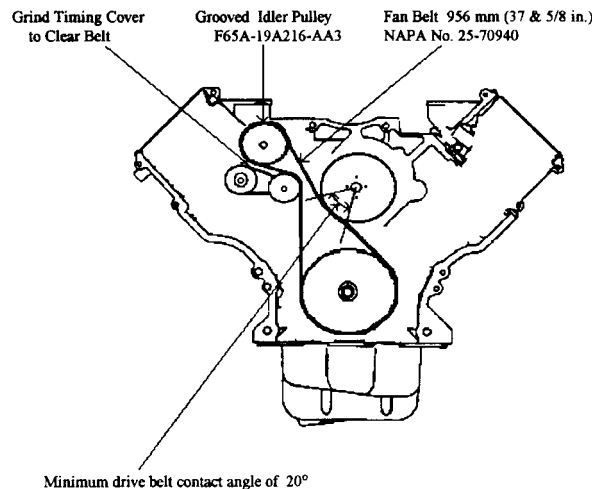
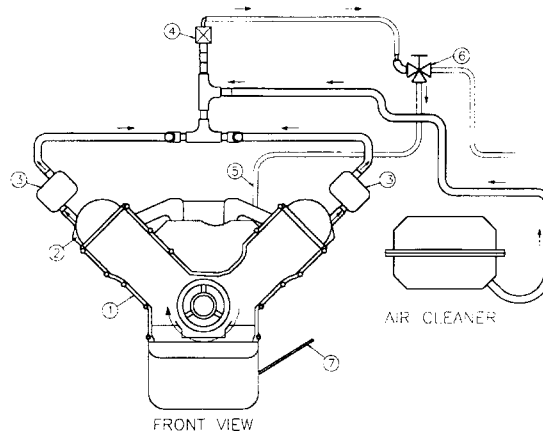

FIG. 3 4.6L Water Pump Drive Arrangement



- NOTE—Legend
- (1) Blowby flows through 6 oil drain back passages in cylinder block and head and through the front cover.
 - (2) Cam baffle shields cover from oil.
 - (3) Oil separator prevents loss of oil into PCV valve.
 - (4) PCV valve flows approximately 120 L/min (4.2 cfm). Blowby rate is 60-70 L/min (2.12-2.47 cfm).
 - (5) Air vent provides balance of flow by PCV valve. When excessive plugging of the PCV valve occurs excess blowby is vented to the engine air intake.
 - (6) Three-way ball valve routes blowby to the intake manifold and provides a connection point for blowby measurement apparatus.
 - (7) Dipstick tube is location for crankcase pressure measurement.

FIG. 4 Functional Description of Closed Crankcase Ventilation System

components and hoses as shown in Fig. A3.17.

7.10.6.1 *Oil Separator and PCV Valve*—Use two clean oil separators and a new PCV valve listed in the parts list Annex A5. Oil separators can be reused as long as they remain serviceable.

7.10.6.2 *Three-Way Valve*—Install a clean three-way valve and attach the PCV valve hose. Install the remaining PCV valve hose between the three-way valve and the intake manifold (see Fig. A3.17). Do not allow the hose to flatten at the bend after installation.

7.10.7 *Intake Air Components*—Install the throttle body, air cleaner assembly, and new air cleaner. Modify the air cleaner assembly to accept fittings for inlet air temperature thermocouple, pressure tap and fresh air, as shown in Fig. A3.1.

7.10.8 *External Hose Replacement*—Inspect all external hoses used on the test stand and replace any hoses that have become unserviceable. Check for internal wall separations that could cause flow restrictions. Check all connections to ensure security.

7.10.9 *Wiring Harness*—There are two wiring harnesses used on the test stand, a dynamometer harness and an engine harness. Obtain the dynamometer wiring harness from the supplier listed in A9.2. The engine harness is listed in Annex A5.

8. Engine Fluids (Supply/Discharge Systems)

8.1 *Intake Air*—Condition the intake air to $30 \pm 0.5^\circ\text{C}$, 11.4 ± 0.8 g/kg humidity, and pressurized to 0.05 ± 0.02 kPa.

8.1.1 *Capacity*—The supply system shall be capable of delivering 110 L/s of conditioned air, while maintaining the intake/air parameters detailed in Table 2. The test stand intake air duct system is shown in Fig. 2.

8.1.2 *Dew Point*—The dew point may be measured in the main system duct or at the test stand. If the dew point is measured in the main system duct, verify the dew point periodically at the test stand. Maintain the duct surface temperature above the dew point temperature at all points downstream of the humidity measurement point to prevent condensation and loss of humidity level.

8.2 Fuel and Fuel System:

8.2.1 *System Description*—A schematic diagram of a typical fuel supply system is shown in Fig. 1. Supply an excess volume of fuel to the fuel rail at all times. Introduce make-up fuel (fuel used by the engine) into the loop from an external source. Mix the make-up fuel with fuel that is returned from the fuel rail (fuel not used by the engine). Pump the fuel through a mixing chamber, or small heat exchanger, which is used to mix the two streams and provide fuel of consistent temperature to the engine. Deliver the fuel to a high-pressure pump (Ford P/N E7TF-9C407 or E7TC-9C407), that boosts the pressure and supplies the fuel to the fuel rail.

8.2.2 *Controls*—Maintain the fuel temperature to the fuel rail below 50°C . To ensure good atomization of the fuel, maintain the fuel pressure to the fuel rail above 185 kPa. In addition, the fuel pressure should be constant at all steady-state conditions to ensure good speed, power, and air-fuel ratio control.

TABLE 2 Sequence VG Operating Specification

Condition	Stage I	Stage II	Stage III
Duration, min	120	75	45
Engine speed, r/min	1200 ± 5	2900 ± 5	700 ± 15
Engine power, kW	record	record	1.30 ± 0.2
Manifold abs press, kPa (abs)	69 ± 0.2	66 ± 0.2	record
Engine oil in, °C	68 ± 0.5	100 ± 0.5	45 ± 1
Engine coolant out, °C	57 ± 0.5	85 ± 0.5	45 ± 1
Engine coolant flow, L/min	48 ± 2	record	record
Engine coolant pressure, kPa (gage)	70 ± 10	70 ± 10	70 ± 10
RAC coolant in, °C	29 ± 0.5	85 ± 0.5	29 ± 1
Rocker cover flow, L/min	15 ± 1	15 ± 1	15 ± 1
Intake, air, °C	30 ± 0.5	30 ± 0.5	30 ± 0.5
Intake air press, kPa (gage)	0.05 ± 0.02	0.05 ± 0.02	0.05 ± 0.02
Lambda, typical values	1.0	1.0	0.75
Lambda	1.00 ± 0.05	1.0 ± 0.05	0.75 ± 0.03
Blowby flow rate, avg, L/min	record	60-70	—
Intake air humidity, g/kg	11.4 ± 0.8	11.4 ± 0.8	11.4 ± 0.8
Exhaust back pressure, kPa abs	104 ± 2	107 ± 2	record
Fuel flow, kg/min	record	record	record

8.2.3 *Fuel Volume Required*—Approximately 3300 L of sequence VG unleaded gasoline are required for each test.

8.2.4 *Fuel Batch Approval Process*—Obtain fuel from the supplier listed in X2.1.5. Each new batch of fuel is approved by the following process:

8.2.4.1 Before initial blending, typical samples of the fuel blend components are analyzed, and the data are compared with predetermined physical specifications. A small amount of fuel mixture is then blended, analyzed, and compared to predetermined specifications. The ASTM Testing Monitoring Center (TMC) confirms the acceptability of the fuel mixture analytical data and authorizes blending of the entire batch for engine testing. After the entire batch is blended, the TMC confirms the acceptability of the analytical data of the entire fuel batch, and authorizes the engine test fuel approval program.

8.2.4.2 A sample of the fuel is shipped to two designated independent laboratories. A designed program involving more than one calibration test is completed using reference oils selected by the TMC. (The Sequence V Reference Oils and Fuels Sub Panel, ASTM D02.B0.01.05, is involved in the design of the program.) The TMC reviews the test results and if acceptable, authorizes the fuel supplier to notify potential purchasers of the approval status of the fuel batch.

8.2.5 *Fuel Batch Analysis*—Upon receipt from the supplier, it is the responsibility of the laboratory to analyze each fuel shipment to determine the value of the parameters shown in Table 3 (except sulfur, oxidation stability, and distillation). Compare the results to the values obtained by the supplier on that particular batch. The results should be within the specification band shown in Table 3 beside each parameter. This provides a method to determine if the fuel batch is contaminated or has aged prematurely. If any results fall outside the tolerances shown in Table 3, the laboratory should contact the TMC for help in resolving the problem. One potential method for resolving the problem is to obtain an analysis at the fuel supplier's laboratory of the *as received* fuel sample.

TABLE 3 VG Fuel Analysis

NOTE—Appearance, water, lead, and oxidation stability are analyzed on an absolute basis.

Parameter	Specification Band
API gravity ^A	58.7–61.2
RVP ^B	60.7–63.4 kPa
Total sulfur ^C	0.01–0.04 wt % max
Existent gum ^D	5 mg/100 mL, max
Distillation ^E	
IBP	22.2–35.0°C
10 %	48.9–57.2°C
50 %	98.9–115.2°C
90 %	162.8–176.7°C
EP	196.1–212.8°C
Appearance	clear and bright
Water ^F	0.01 vol %, max
Lead ^G	10 mg/L max
Oxidation stability ^H	1440 minutes, min

^A In accordance with Test Method D 1298 or D 287.

^B In accordance with Test Method D 323 or Automatic Reid Vapor Pressure.

^C In accordance with Test Method D 4294, D 1266, or D 2622.

^D In accordance with Test Method D 381.

^E In accordance with Test Method D 86.

^F In accordance with Test Method D 6304.

^G In accordance with Test Method D 3237 or D 5059.

^H In accordance with Test Method D 525.

8.2.6 *Laboratory Storage Tank Fuel Analysis*—Analyze the contents of each fuel storage tank that contains fuel used for calibrated Sequence VG tests bimonthly. Analyze fuel in run tanks, those with a direct feed line to test engines, every month. Laboratories should take composite samples using Table 1 in Practice D 4057, as a guideline. The fuel supplier shall have the capability to analyze the fuel samples using the test methods specified in Table 3 and this section. The fuel supplier shall provide an adequate supply of fuel sample containers with packaging and pre-addressed return labels to each Sequence VG laboratory. Upon receipt of all fuel samples required in 8.2.6 from the laboratories, the fuel supplier shall perform the following analyses, report the results to the submitting laboratory, and tabulate the results in a database.

Reid vapor pressure (Test Method D 323)

Washed gums (Test Method D 381)

API gravity (Test Method D 287 or D 1298)

Unwashed gums (Test Method D 381)

Distillation (Test Method D 86)

Lead (Test Method D 3237 or D 5059)

8.2.6.1 When results from the physical and chemical tests listed above appear to differ significantly from the expected results, analyze a second sample, or conduct the following tests, or do both:

Hydrocarbon speciation (Test Method D 2789)

Oxidation stability (Test Method D 525)

Potential gums (Test Method D 873)

8.2.6.2 The fuel supplier shall also issue a bimonthly analysis of the fuel from the main storage tank, which should represent normal aging. The analysis shall include the parameters in Table 3.

8.2.6.3 Forward the results of the analyses performed in 8.2.6 and 8.2.6.1 to the TMC for inclusion in the appropriate data base.

8.2.7 *Fuel Batch Shipment and Storage*—Ship the fuel in containers with the minimum allowable venting as dictated by all safety and environmental regulations, especially when shipment times are anticipated to be longer than one week. Store the fuel following all applicable safety and environmental regulations.

8.3 *Engine Oil and Engine Oil System* :

8.3.1 *Test Oil Description:*

8.3.1.1 The test oil sample shall be uncontaminated and representative of the lubricant formulation being evaluated.

8.3.1.2 A minimum of 7.5 L of new oil is required to complete the test. A 20 L sample of new oil is normally provided to allow for inadvertent losses.

8.3.2 *System Description:*

8.3.2.1 Configure the oil system as shown in Fig. A3.8 to minimize stand-to-stand variations that could influence test severity. Measure engine oil pressure at the points shown in Fig. 5. The oil flow rate and external pressure drop are controlled by specifying the volume, plumbing configuration, and orientation of the heat exchanger. The oil flow out of the vertically mounted heat exchanger shall be level with the oil-in thermocouple. The lengths of the lines are not specified although the line diameters are indicated in Fig. A3.8. The line length and diameter have a large influence on the volume of the external system. The internal volume of the entire external system shall be 540 ± 30 mL.

8.3.2.2 Use oil filter adapter OHT6A-0007-1 (X2.1.11), oil filter OHT6A-012-2 (X2.1.11) or OHT6A-012-2LS (X2.1.11). Be sure all hoses and fittings on the oil heat exchanger are properly connected and secure. *The external oil system components shall not be brass, copper or galvanized, as these metals may influence used oil analysis.*

8.3.3 *Heat Exchanger*— The heat exchanger has been chosen to minimize the volume of the external system. The heat exchanger has adequate but not excessive capacity to control the oil temperature. The system requires a high level of maintenance to provide adequate cooling, especially when process water temperature is high. An effective, well-maintained process water control system is necessary to achieve the specified oil temperatures. Use vertically mounted ITT heat exchanger P/N 5-160-02-008-002 (X2.1.9). Configure the system to allow the process water to flow through the vertical tubes and the oil through the shell. This orientation will facilitate cleaning of the tubes.

8.3.4 *System Cleaning:*

8.3.4.1 Clean the external oil cooling system thoroughly before each test. An acceptable technique for cleaning the oil heat exchanger is detailed in Annex A6. Flush and rinse the external lines before each test. The specific technique used (removed from or flushed on the stand, and so forth) is left to the discretion of the laboratory.

8.3.4.2 Regardless of the flushing technique employed, use an organic solvent (see 7.7.2) for the final flushing followed by separate rinses with hot ($> 60^{\circ}\text{C}$) water and degreasing solvent (7.7.1) before air-drying the components. (**Warning**—Incomplete cleaning of the external oil system may allow debris to dislodge and circulate throughout the engine during subsequent tests. Incomplete cleaning may also cause oil temperature control problems and contaminate subsequent test oils.)

8.3.5 *Control Specifications*—The operating conditions are specified in Table 2. Additional information concerning the oil pressure, is found in 12.5.7. Cyclic ramping specifications are detailed in Table 4.

8.4 *Coolants:*

8.4.1 *Description*— The engine coolant is equal parts of demineralized (less than 0.34 g/kg) or distilled water and a fully formulated ethylene glycol based automotive antifreeze to protect against corrosion of all system components. The RAC coolant