



Designation: ~~D 1253-03~~ Designation: D 1253 - 08

Standard Test Method for Residual Chlorine in Water¹

This standard is issued under the fixed designation D 1253; the number immediately following the designation indicates the year of original adoption or, in the case of revision, the year of last revision. A number in parentheses indicates the year of last reapproval. A superscript epsilon (ϵ) indicates an editorial change since the last revision or reapproval.

This standard has been approved for use by agencies of the Department of Defense.

1. Scope *

1.1 This test method covers the determination of residual chlorine in water by direct amperometric titration.

1.2 Within the constraints specified in Section 6, this test method is not subject to commonly encountered interferences and is applicable to most waters. Some waters, however, can exert an iodine demand, usually because of organic material, making less iodine available for measurement by this test method. Thus, it is possible to obtain falsely low chlorine readings, even though the test method is working properly, without the user's knowledge.

1.3 Precision data for this test method were obtained on estuary, inland main stem river, fresh lake, open ocean, and fresh cooling tower blowdown water. Bias data could not be determined because of the instability of solutions of chlorine in water. It is the user's responsibility to ensure the validity of the test method for untested types of water.

1.4 In the testing by which this standard was validated, the direct and back starch-iodide titrations and the amperometric back titration, formerly part of this standard, were found to be unworkable and were discontinued in 1986. Historical information is presented in Appendix X1.

NOTE 1—Orthotolidine test methods have been omitted because of poor precision and accuracy.

1.5

1.5 The values stated in SI units are to be regarded as standard. No other units of measurement are included in this standard.

1.6 *This standard does not purport to address all of the safety concerns, if any, associated with its use. It is the responsibility of the user of this standard to establish appropriate safety and health practices and determine the applicability of regulatory limitations prior to use.*

2. Referenced Documents

2.1 *ASTM Standards:*²

D 1129 Terminology Relating to Water

D 1193 Specification for Reagent Water

D 2777 Practice for Determination of Precision and Bias of Applicable Test Methods of Committee D19 on Water

D 3370 Practices for Sampling Water from Closed Conduits

D 5847 Practice for Writing Quality Control Specifications for Standard Test Methods for Water Analysis

3. Terminology

3.1 *Definitions:* For definitions of terms used in this test method, refer to Terminology D 1129.

3.2 *Definitions of Terms Specific to This Standard:*

3.2.1 ~~combined residual chlorine~~; combined residual chlorine, *n*—residual consisting of chlorine combined with ammonia nitrogen or nitrogenous compounds.

3.2.2 ~~free available chlorine residual~~; residual, *n*—residual consisting of hypochlorite ions, hypochlorous acid, or a combination thereof.

3.2.3 ~~total residual chlorine (chlorine residual)~~; *n*—the amount of available chlorine-induced oxidants present in water at any specified period, subsequent to the addition of chlorine.

NOTE 2—Chlorine present as chloride is neither included in these terms nor determined by this test method.

¹ This test method is under the jurisdiction of ASTM Committee D19 on Water and is the direct responsibility of Subcommittee D19.05 on Inorganic Constituents in Water. Current edition approved June 10, 2003. Published July 2003. Originally approved in 1953. Last previous edition approved in 1996 as D1253-86 (1996). Current edition approved Oct. 1, 2008. Published October 2008. Originally approved in 1953. Last previous edition approved in 2003 as D 1253 - 03.

² For referenced ASTM standards, visit the ASTM website, www.astm.org, or contact ASTM Customer Service at service@astm.org. For *Annual Book of ASTM Standards* volume information, refer to the standard's Document Summary page on the ASTM website.

*A Summary of Changes section appears at the end of this standard.

NOTE 3—Bromine, bromine combined with ammonia or nitrogenous compounds, and chlorine dioxide are not distinguished by this test method from the corresponding chlorine compounds.

4. Summary of Test Method

4.1 This is an amperometric titration test method utilizing phenylarsine oxide as the titrant. When the titrator cell is immersed in a sample containing chlorine, current is generated. As phenylarsine oxide is added, the chlorine is reduced and the generation of current ceases. When chlorine is present as a chloramine, potassium iodide is added, releasing iodine, which is titrated in a similar manner. The iodine content is calculated in terms of free chlorine.

5. Significance and Use

5.1 Chlorine is used to destroy or deactivate a variety of unwanted chemicals and microorganisms in water and wastewater.

5.2 An uncontrolled excess of chlorine in water, whether free available or combined, can adversely affect the subsequent use of the water.

6. Interferences

6.1 This test method is not subject to interferences from temperature, color, or turbidity of sample.

6.2 Values of pH above 8.0 interfere by slowing the reaction rate. Buffering the sample to pH 7.0 or less eliminates the interference.

6.3 Erratic behavior of the apparatus in the presence of cupric ions has been reported.

6.4 Cuprous and silver ions tend to poison the electrode of the titrator.

6.5 Nitrogen trichloride and some N-chloro compounds are often present as products of the chlorination of wastewaters and will titrate partially as free available chlorine and partially as combined residual chlorine. This error can be avoided only in the determination of total residual chlorine.

6.6 Exposure to high concentrations of free available chlorine causes a film-type polarization that reverses very slowly. This can be avoided by diluting the sample with water to less than 10 mg/L of free available chlorine.

6.7 If chlorine dioxide is present, an unknown portion titrates as free available chlorine. Total chlorine dioxide titrates as total residual chlorine.

6.8 Depending upon final pH, chlorination of waters containing ammonia or nitrogenous organic compounds can produce high concentrations of dichloramine. This compound produces four to five times as much current as monochloramine. The current produced by as little as 5 mg/L of dichloramine can cause the microammeter pointer to read offscale even at the end point in the titration of free available chlorine. This may be overcome by use of an opposing voltage in the apparatus' circuitry. The instrument's manufacturer should be consulted in this regard.

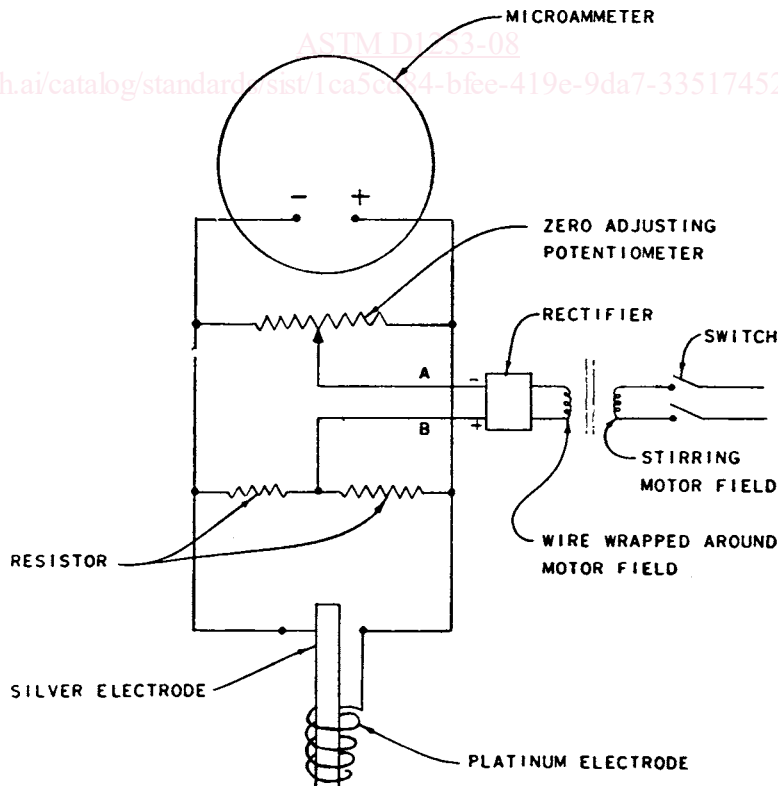

FIG. 1 Wiring Diagram of Amperometric Titrator

7. Apparatus

7.1 Amperometric Titration Apparatus^{3,4}—Refer to Fig. 1.

NOTE 4—When the titrator has been out of service for a day or more, check the electrode for sensitivity by noting the rapidity of the pointer deflection. If the pointer responds slowly after the addition of KI solution, add a small amount of biiodate. If it responds slowly to free available chlorine, sensitize it by adding chlorine.

7.2 *Glassware*—Condition with water containing at least 10 mg/L of residual chlorine for at least 2 h prior to use and then rinse thoroughly.

8. Reagents and Materials

8.1 *Purity of Reagents*—Reagent grade chemicals shall be used in all tests. Unless otherwise indicated, it is intended that all reagents shall conform to the specifications of the Committee on Analytical Reagents of the American Chemical Society.⁵ Other grades may be used, provided it is first ascertained that the reagent is of sufficiently high purity to permit its use without lessening the accuracy of the determination.

8.2 *Purity of Water*— Unless otherwise indicated, references to water shall be understood to mean reagent water conforming to Specification D 1193, Type III, further treated to be free of chlorine demand. A suggested method for preparation of chlorine demand-free water is to add approximately 20 mg/L of available chlorine to Type III water, let it stand for about a week in darkness, and then expose it to sunlight until no chlorine remains. Type III, further treated to be free of chlorine demand. Other reagent water types (Type I) may be used provided it is first ascertained that the water is of sufficiently high purity to permit its use without adversely affecting the bias and precision of the test method. Type III water was specified at the time of round robin testing of this method. A suggested method for preparation of chlorine demand-free water is to add approximately 20 mg/L of available chlorine to Type III water, let it stand for about a week in darkness, and then expose it to sunlight until no chlorine remains. Filtration through a carbon filter is an alternative process which requires less time to remove chlorine.

8.3 *pH 4.0 Buffer Solution*—Dissolve 243 g of sodium acetate trihydrate and 480 g of glacial acetic acid in water and dilute to 1 L.

8.4 *pH 7.0 Buffer Solution*—Dissolve 25.4 g of monobasic potassium phosphate and 86 g of dibasic sodium phosphate in water and dilute to 1 L.

8.5 *Biiodate, Solution Standard (0.0282N)*—Dissolve 0.9163 g of potassium biiodate in water and dilute to 1 L in a volumetric flask. Store in an amber glass-stoppered bottle.

8.6 *Phenylarsine Oxide, Solution Standard (0.00564 N)*—Dissolve 0.8 g of phenylarsine oxide in 150 mL of sodium hydroxide solution (12 g/L). After settling, decant 110 mL of this solution, add 800 mL of water, and bring to a pH of 9.0 by adding hydrochloric acid (1 + 1). This should require about 2 mL of HCl (1 + 1). Continue acidification with HCl (1 + 1) until a pH of 6 to 7 is reached, as indicated by a glass-electrode system; then dilute to a total volume of 1L. Standardize to 0.00564 N against 0.0282 N biiodate solution using the titrator (7.1) as the end-point indicator. Add 1 mL of chloroform for preservation.

8.7 *Potassium Iodide Solution (50 g/L)*—Dissolve 50 g of KI in water and dilute to 1 L. Add 1 g of sodium bicarbonate to stabilize the solution. Store in an amber bottle and avoid direct exposure to sunlight.

9. Sampling

9.1 Collect the sample in accordance with Practices D 3370. Take care that the sample is representative and keep it away from direct sunlight prior to analysis.

9.2 All tests should be made as soon as possible after collection of the sample (not more than 5 min) because the residual chlorine may diminish with time, due to the chlorine demand of the sample. Where time of contact is important, the elapsed time between the addition of chlorine and the determination of chlorine should be taken into account.

10. Procedure

10.1 For residual chlorine concentrations of 2.0 mg/L or less, use a 200-mL sample. For greater concentrations, use a 100-mL sample. It is preferable that the size of the sample be such that not more than 2 mL of titrant will be required to complete the titration.

10.2 Determination of Total Residual Chlorine:

10.2.1 Add 1 mL of KI solution to a 200-mL sample and immediately add 1 mL of pH 4.0 buffer solution.

10.2.2 Immerse the electrodes in the sample and start the stirrer. Adjust the microammeter pointer of the potentiometer to the right or high current side of the scale so the pointer can deflect counterclockwise during the analysis.

³ *Annual Book of ASTM Standards*, Vol 11.02: Water and Sewage Works, May 1949, p. 171, and *Journal American Water Works Association*, Vol 34, 1942, pp. 1227–1240.

⁴ *Water and Sewage Works*, May 1949, p. 171, and *Journal American Water Works Association*, Vol 34, 1942, pp. 1227–1240.

⁴ Amperometric titrators are available commercially from most laboratory supply houses.

⁵ Amperometric titrators are available commercially from most laboratory supply houses.

⁵ *Reagent Chemicals, American Chemical Society Specifications*, American Chemical Society, Washington, DC. For Suggestions on the testing of reagents not listed by the American Chemical Society, see *Annual Standards for Laboratory Chemicals*, BDH Ltd., Poole, Dorset, U.K., and the *United States Pharmacopeia and National Formulary*, U.S. Pharmacopeial Convention, Inc. (USPC), Rockville, MD.