



Designation: ~~D2395-07a~~ Designation: D 2395 – 07a^{ε1}

Standard Test Methods for Specific Gravity of Wood and Wood-Based Materials¹

This standard is issued under the fixed designation D 2395; the number immediately following the designation indicates the year of original adoption or, in the case of revision, the year of last revision. A number in parentheses indicates the year of last reapproval. A superscript epsilon (ϵ) indicates an editorial change since the last revision or reapproval.

This standard has been approved for use by agencies of the Department of Defense.

^{ε1} NOTE—Editorial corrections were made throughout in October 2008.

1. Scope

1.1 These test methods cover the determination of the specific gravity of wood and wood-based materials to generally desired degrees of accuracy and for specimens of different sizes, shapes, and moisture content conditions. The method title is indicative of the procedures used or the specific area of use.

Method A—Volume by Measurement
Method B—Volume by Water Immersion
Method C—Flotation Tube
Method D—Forstner Bit
Method E—Increment Core
Method F—Chips

Section
—Test Method A—Volume by Measurement
—Test Method B—Volume by Water Immersion
Test Method C—Flotation Tube
Test Method D—Forstner Bit
Test Method E—Increment Core
Test Method F—Chips

1.2 *This standard does not purport to address all of the safety concerns, if any, associated with its use. It is the responsibility of the user of this standard to establish appropriate safety and health practices and determine the applicability of regulatory limitations prior to use.*

2. Referenced Documents

2.1 ASTM Standards:²

D 9 Terminology Relating to Wood and Wood-Based Products
D 2555 Practice for Establishing Clear Wood Strength Values
D 4442 Test Methods for Direct Moisture Content Measurement of Wood and Wood-Base Materials
D 4444 Test Method for Laboratory Standardization and Calibration of Hand-Held Moisture Meters
E 1547 Terminology Relating to Industrial and Specialty Chemicals

2.2 Other Standards:

CAN/CSA O86 Engineering Design in Wood³

ANSI/AF&PA National Design Specification for Wood Construction⁴

3. Terminology

3.1

3.1 Definitions:

3.1.1 *green volume, n*—the solid wood volume before any shrinkage occurs due to drying to moisture content below the fiber saturation point (about 30 %).

3.1.2 *moisture content, n*—~~in this standard, the~~ the amount of water contained in wood, expressed as a percentage of the mass of oven-dry wood.

3.1.2.1 *Discussion*—In general, the amount of water in wood can be expressed on two different bases: as a percentage of the

¹ These test methods are under the jurisdiction of ASTM Committee D07 on Wood and are the direct responsibility of Subcommittee D07.01 on Fundamental Test Methods and Properties.

Current edition approved July 1, 2007. Published July 2007. Originally approved in 1965. Last previous edition approved in 2007 as D 2395 – 07.

² For referenced ASTM standards, visit the ASTM website, www.astm.org, or contact ASTM Customer Service at service@astm.org. For *Annual Book of ASTM Standards* volume information, refer to the standard's Document Summary page on the ASTM website.

³ Additional information on this test method may be obtained from TAPPI 258 om-02, Basic Density and Moisture Content of Pulpwood. Available from TAPPI, 15 Technology Parkway South, Norcross, GA 30092.

³ Available from Canadian Standards Association (CSA), 5060 Spectrum Way, Mississauga, ON L4W 5N6, Canada, <http://www.csa.ca>.

⁴ Simpson, W. T., "Specific Gravity, Moisture Content, and Density Relationship for Wood," USDA Forest Service, Forest Products Laboratory General Technical Report FPL-GTR-76.

⁴ Available from American Forest and Paper Association (AF&PA), 1111 19th St., NW, Suite 800, Washington, DC 20036, <http://www.afandpa.org>.

mass of oven-dry wood, or a percentage of the total mass of wood and water. To avoid misunderstandings, it must be clear which basis is being used. In the forest industry and the wood products industry, the moisture content is usually expressed as a percentage of the mass of oven-dry wood.

3.1.3 *specific gravity, n* —~~in this standard, the~~ the ratio of the oven-dry mass of a specimen to the mass of a volume of water equal to the volume of the specimen at a specified moisture content.

3.1.3.1 *Discussion*—As both the mass and volume of wood vary with the amount of moisture contained in the wood, specific gravity as applied to wood is an indefinite quantity unless the conditions under which it is determined are clearly specified. The specific gravity of wood is based on the oven-dry mass, but the volume may be that in the oven-dry, partially dry, or green condition. For further discussion, see Appendix X2.

3.1.3.2 *specific gravity at $X\%M$ % moisture content, n* —specific gravity based on oven-dry mass of wood and its volume at a specified moisture content ($X\%$) between the oven-dry condition and the fiber saturation point (volume at 12 % moisture content is frequently used).

3.1.3.3 *specific gravity, basic, n* —specific gravity based on oven-dry mass of wood and its green volume.

3.1.3.4 *specific gravity, ~~oven-dry~~, oven-dry or on oven-dry basis, n* —specific gravity based on oven-dry mass of wood and its oven-dry volume.

4. Summary of Test Methods

4.1 The accuracy of the specific gravity value obtained on a representative specimen will depend upon the accuracy of the measurements made. If the specimens are carefully prepared and regular in shape, the volume determined by Test Method A can be quite exact. The volume of irregularly shaped specimens can best be determined by immersion in water and if due care is taken to prevent absorption of water, Test Method B will give results of great precision. Test Method C is an approximate method but a procedure that can be very useful, particularly as part of a production procedure. Test Methods D and E are especially adapted to specific gravity measurements of living trees or of in-place elements and the accuracy of the result is dependent upon the care used in obtaining the specimen. Test Method F is a specific procedure for wood chips.

5. Significance and Use

5.1 The specific gravity of wood gives an excellent measure of the amount of wood substance present in a sample. Thus, it may serve as a valuable indicator of the amount of wood pulp that could be produced, the workability of the material, or the strength characteristics of a specimen or a species. It should be recognized that specific gravity varies between trees, within a tree, and between species. Since the specific gravity of wood substance is practically constant for all species (approximately 1.53), it is apparent that individual specific gravity values are indicative of the amount of wood substance present. It affords a rapid and valuable method for selection of wood for specific uses.

5.2 It may be desirable to know the specific gravity of a living tree, a structural member already in place, a log cross section, a segment of a research element, or the earlywood or latewood layer. The specimen thus may be large or small, regular or irregular, and at a variety of moisture contents. These test methods give procedures that include all of these variables and provides for calculation of specific gravity values to degrees of accuracy generally needed.

6. Test Specimens

6.1 The specific gravity specimens shall be fully representative of the material from which they are taken. The specimen size shall be such that accurate measurements of mass and volume are easy to attain. Where other standards specify the location and size of specific gravity specimens, these requirements shall be carefully followed. The specimens shall be carefully cut from the larger element to ensure clean-cut surfaces. All loose fibers shall be carefully removed before the specimen is weighed and measured. The specimen shall be free from knots, and if pitch or other infiltrates are present, this shall be noted in the report or they shall be extracted before specific gravity values are obtained.

6.2 *Measurements*—The dimensions of test specimens shall be measured to a precision of $\pm 0.3\%$ or less, and the mass shall be determined to a precision of $\pm 0.2\%$ or less. Where drying of specimens is required, this shall be done in an oven maintained at $103 \pm 2^\circ\text{C}$. (For most panel materials and wood specimens 1 in. (25 mm) in length parallel to grain, drying for 48 h in an oven having good air circulation and exchange will be sufficient to reach constant mass.)

7. TEST METHOD A—VOLUME BY MEASUREMENT

7.1 Applicability:

7.1.1 *Shape of Specimen*—The specimen must be regular in shape with right-angle corners for determination of volume by lineal measurement. The procedure is adaptable to any size of specimen or to specimens of any moisture content. If the surfaces of the specimen are smooth and sufficient measurements are taken, the volume can be obtained with considerable accuracy. Special care must be taken in measurement of very small or thin specimens. Volume of irregular or rough-surfaced specimens should be obtained by Test Method B.

7.2 Procedures:

7.2.1 *Measurement*—Measure the length (L), width (w), and thickness (t) of the specimen in accordance with 6.2 in a sufficient number of places to ensure an accurate indication of volume. In small specimens, uniform in size, one or two measurements of

each dimension will suffice; in larger specimens the number of measurements will depend on the uniformity of the specimen, but at least three measurements of each dimension will be required.

7.2.2 *Mass*—Determine the initial mass (m_M) of the specimen at the time of test in accordance with 6.2.

7.2.3 *Moisture Content*—Determine the moisture content (M) of the specimen to permit description of the basis on which the specific gravity is computed. Test Methods D 4442 and D 4444 indicate procedures that should be used.

7.2.4 *Small Specimens*—The entire specimen may be used for determination of moisture content.

7.2.5 *Intermediate Specimens*—When the specimen is of a size that is unsuitable for moisture content determinations (the time to oven-dry to constant mass would be excessive), a segment may be cut from the specimen for a moisture content specimen. Select this segment so that its moisture content is representative of that of the larger specimen. Where possible in solid wood elements, the moisture content specimen shall be of full cross-sectional dimensions and 1 in. (25 mm) in length (parallel to grain). In sheet materials the specimen shall be equal in thickness to the thickness of the material and 3 by 6 in. (76 by 122 mm) in size.

7.2.6 *Structural Elements*—In full-sized members, determine the moisture content from a segment cut from the member. It shall be of full cross-sectional dimensions and 1 in. (25 mm) in length (parallel to grain), and shall be selected from a representative area of the member. To avoid the effects of end drying, cut the specimen at least 18 in. (457 mm) in from the end of the member.

7.2.7 *Special Situations*—Where the specimen or element cannot be cut to secure a moisture content segment, an approximate moisture content may be obtained through the use of a moisture meter which is used in accordance with the manufacturer's recommendations. Since the moisture content value is approximate, it should be recognized that the specific gravity value obtained will also be approximate.

7.2.8 *Specimen Preparation*—When the moisture content specimen is a portion of the element, remove all loose particles from the specimen and determine the initial mass (m) in accordance with m_M in accordance with 6.2.

7.3 *Drying*—Oven-dry the moisture content specimen to constant mass in accordance with 6.2, and determine the oven-dry mass (m_0).

8. TEST METHOD B—VOLUME BY WATER IMMERSION

8.1 *Applicability:*

8.1.1 *Type of Specimen*—This procedure is particularly adaptable to specimens of irregular shape or having a rough surface. Limitations on specimen size are based primarily on size of immersion tanks available. In small size specimens, less than 1 cm³ in volume, air bubbles adhering to the specimen surface can result in considerable error in volume measurement and thus to the computed specific gravity value. Freshly cut green wood will not absorb appreciable quantities of water during the brief immersion period. As soon as any drying of the wood has taken place however, the surface must be sealed before immersion in water or else the volumetric displacement of the wood specimen will be in error in an amount equal to the volume of water absorbed by the wood.

8.2 *Procedures:*

8.2.1 *Mass*—Determine the initial mass (m_M) of the specimen at time of test in accordance with 6.2.

8.2.2 *Volume*—Determine the volume of the specimen by one of the following modes. Volume may be determined in the as received condition if the specimen is green; or in the as received condition if the specimen is partially dry or after oven-drying if the pores are adequately sealed (see 8.2.2.5). Determine the volume of the specimen by measuring the volume of water displaced or by determining the mass of the water displaced. The mass in grams is numerically equal to the volume in cubic centimetres.

8.2.2.1 *Mode I*—Place the specimen in a tank of known volume and add sufficient water to fill the tank. Then remove the specimen and determine the volume of water remaining. The tank volume less the volume of water remaining is equal to the volume of the specimen. The relationship between specimen volume and tank volume shall be such that the precision of specimen volume measurement is high.

8.2.2.2 *Mode II*—Place a container holding enough water to completely submerge the specimen on one pan of a balance as shown in Fig. 1. Then balance the combined mass of the container and water with mass added to the other pan. Hold the specimen so that it is completely submerged without touching the sides of the container by means of a sharp, pointed, slender rod and balance the scales again. The mass added to restore balance is equal to the mass of water displaced by the specimen. Alternatively, an automatic balance may be used and will greatly facilitate the speed of such measurements. If very small specimens are used, the accuracy of resulting data is likely to be low.

8.2.2.3 *Mode III*—Place a container holding enough water to completely submerge the specimen below one pan of a balance as shown in Fig. 2. The container shall be sufficiently large so that immersion of the specimen causes no material change in water level. Suspend a wire basket of sufficient mass to hold the specimen submerged from this same pan and immerse it in the water. Balance the mass of the basket when freely immersed with mass added to the other scale pan. Weigh the specimen in air. Place the specimen in the basket and hold it completely submerged without touching the container while balancing the scales again. The mass added to restore balance, if the specimen is lighter than water, plus the mass of the specimen in air equals the volume of water displaced. If the specimen is heavier than water, subtract the mass added to restore balance from the mass of the specimen in air to determine the volume of water displaced.

8.2.2.4 *Mode IV*—Immerse the specimen, of an elongated shape, in a graduated tube having a cross section only slightly larger than that of the specimen as shown in Fig. 3. Read the water level in the tube, preferably to an even graduation mark, before immersing the specimen. Immerse the specimen, hold it submerged with a slender pointed rod if necessary, and determine the water

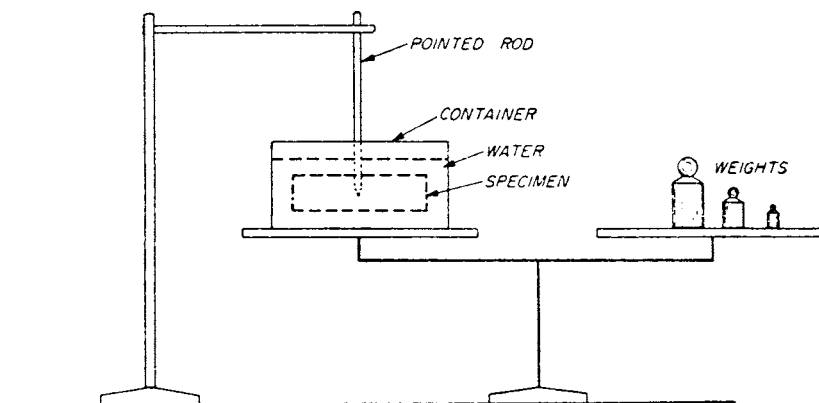

FIG. 1 Diagrammatic Sketch of Apparatus Used to Measure Volume of Specimens by Test Method B-II

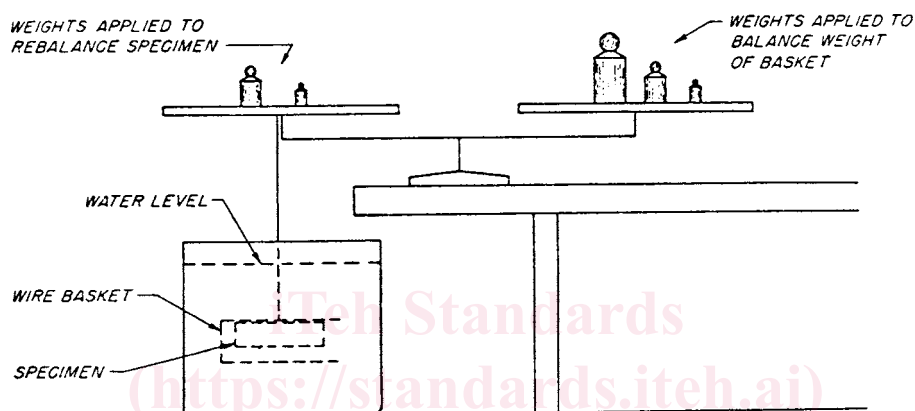

FIG. 2 Diagrammatic Sketch of Apparatus Used to Measure Volume of Specimens by Test Method B-III

level again. The difference in water level is equal to the volume of the specimen.

8.2.2.5 *Surface Treatment of Specimen*— Green specimens may be immersed in water for volume determinations without material absorption of water that will affect volume determinations. Dip air-dry or oven-dry specimens in hot paraffin wax before making volume determinations. After the wax dip, weigh the specimen again and use this mass in conjunction with the immersed mass for determining volume in Mode II and Mode III (8.2.2.2 and 8.2.2.3). Alternatively, softwood specimens or hardwood specimens with small pores may be dipped in a solution of paraffin wax in carbon tetrachloride: 1 oz of paraffin wax in 260 in.³ of carbon tetrachloride (1 g of paraffin wax in 150 cm³ of carbon tetrachloride). Before immersion, allow the carbon tetrachloride to evaporate for a few minutes. The gain in mass due to the thin film of wax deposited is negligible. This test method may be effectively used on air-dry specimens since thin wax film does not appear to affect shrinkage when the specimen is oven-dried. (**Warning**—Observe necessary precautions to ensure proper ventilation when carbon tetrachloride is used.)

8.2.3 *Moisture Content*—Determine the moisture content (M) of the specimen to permit description of the basis on which the specific gravity is computed.

8.2.3.1 *Specimen*—The entire specimen or a representative segment may be used for the moisture content determination. Remove all loose particles from the specimen and determine the initial mass (F) in accordance with m_M in accordance with 6.2.

8.2.4 *Drying*—Oven-dry the moisture content specimen to constant mass in accordance with 6.2 and determine the oven-dry mass (F_{m_0}).

9. TEST METHOD C—FLOTATION TUBE

9.1 Applicability:

9.1.1 *Type of Specimen*—This procedure provides a rapid means for obtaining an approximate specific gravity for an elongated specimen of uniform cross section and known moisture content.

NOTE 1—Estimates of specific gravity to the nearest 0.02 can be readily made.

9.2 Procedures:

9.2.1 *Specimen Preparation*—The specimen shall be slender and of uniform cross section, preferably about 1 in. (25 mm) on a side and 10 in. (254 mm) long. The moisture content may be any known value.

9.2.2 *Measurement*—Place the specimen in a slender cylinder filled with water and allow it to float in as nearly a vertical position as possible (Fig. 4). The cylinder diameter shall be but little slightly larger than the specimen cross section, and the

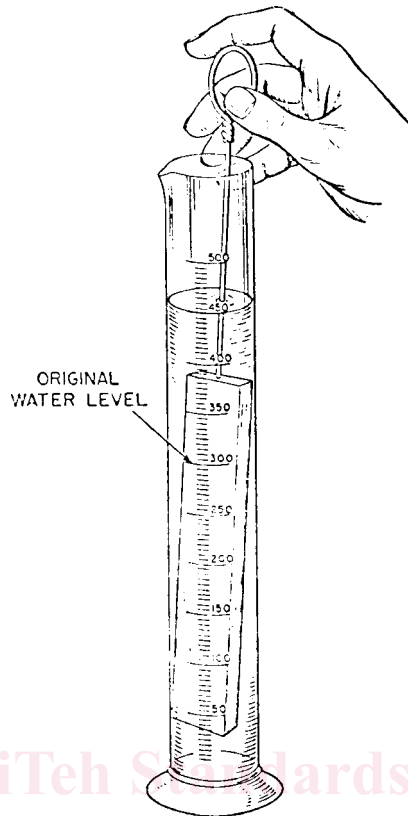

FIG. 3 Test Method of Measuring Volume of Elongated Specimens Using a Graduated Tube

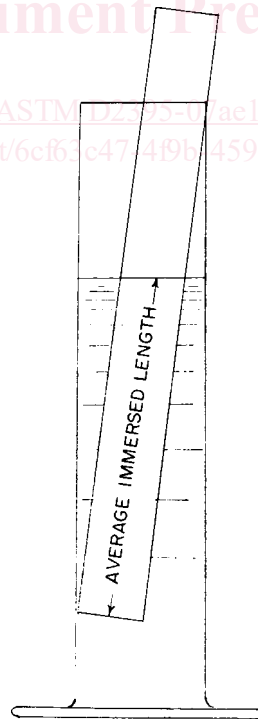

FIG. 4 Cylinder and Specimen Used in Flotation Tube Test Method of Specific Gravity Determination

specimen shall not touch the cylinder wall until immersed as far as it will go. With the specimen floating in an upright position, quickly mark the water level on the specimen to avoid excessive absorption of water by the specimen.

10. TEST METHOD D—FORSTNER BIT

10.1 Applicability:

10.1.1 *Type of Specimen*—This procedure is particularly adaptable for determining the specific gravity of logs, timbers, or any in-place elements from which it would be difficult to saw a more conventional sample. The Forstner-type bit does not have a lead screw, and volume of material can be readily obtained from the diameter of the bit and the depth of the hole. Care ~~must~~shall be taken to collect all of the shavings.

10.2 Procedures:

10.2.1 *Volume*—Obtain the volume of specimen material by boring a hole into the element in question with a Forstner-type bit. The diameter of hole and depth of boring shall be such that an adequate sample is obtained without damage to the element. Accurately measure the diameter of the bit and depth of the hole. Use these dimensions to calculate the specimen volume.

10.2.2 *Mass*—Carefully collect all of the chips obtained by boring and immediately weigh them to determine the initial mass ($f m_M$).

10.2.3 *Moisture Content*—Determine the moisture content (M) to permit description of the basis on which the specific gravity is computed.

10.2.4 *Drying*—Oven-dry the chips to constant mass in accordance with 6.2 and determine the oven-dry mass ($F m_0$).

11. TEST METHOD E—INCREMENT CORES

11.1 Applicability:

11.1.1 This procedure is particularly adaptable for obtaining specimens to determine the specific gravity of standing trees but is also suitable for use on logs, poles, piles, or other structural elements. Since only a pencil-sized hole is made in the member in question, it has no material effect on the properties of the member and can be easily sealed.

11.2 Procedures:

11.2.1 *Volume*—Obtain the specimen material by extracting a core from the member by means of a standard increment borer. Obtain the volume from the diameter of the cutting edge of the increment borer and measure the length of the core immediately after it is removed from the member. Handle the core carefully to prevent damage or loss of any portion.

11.2.2 *Mass*—When the moisture content of the element is desired, weigh the increment core immediately after the length is measured in order to obtain the initial mass ($f m_M$). If this is impossible, the core must be protectively wrapped to prevent loss of moisture.

11.2.3 *Drying*—Oven-dry the increment core to constant mass in accordance with 6.2 and determine the oven-dry mass.

~~12. METHOD F—Determine the oven-dry mass (m_0).~~

12. TEST METHOD F—CHIPS ⁵

12.1 Applicability:

12.1.1 This procedure is specifically designed to determine the specific gravity of wood chips. This is most often obtained on a green volume, oven-dry mass basis, although other specific gravity values can be obtained.

12.2 Procedures:

12.2.1 *Specimen*—Select a representative sample of chips weighing 0.66 to 0.77 lb (approximately 300 to 350 g) for test. Remove sawdust and undersized chips by shaking on a three-mesh sieve.

12.2.2 *Mass*—Obtain the initial mass ($f m_M$) of the chips in accordance with 6.2.

12.2.3 *Volume*—Submerge the chips in water at room temperature for at least 1 h to ensure that they are at their green volume and will not absorb water during volume measurement. Then remove them from the water, allow them to drain in a wire-mesh basket, and place them in the centrifuge basket. Centrifuge the chips from 800 to 1200 rpm for 1 to 4 min.

12.2.3.1 Place a container holding enough water to freely submerge the chip holder on one scale pan and balance it. Submerge the empty chip holder, except for its wire handle, in the water container. The chip holder must not touch the sides or bottom of the container, and shall be balanced by mass which represent the volume of water equivalent to that of the empty chip holder. Transfer the chips to the chip holder and slowly lower them into the container of water, being careful to remove any entrapped air. Balance the scale and obtain the mass necessary to balance the volume of water equal to the volume of chips (V).

12.2.4 *Drying*—Remove the chips and oven-dry to constant mass in accordance with 6.2 to determine the oven-dry mass ($F m_0$).

13. Calculation

~~13.1 Moisture Content (M , %)~~

~~13.1.1 If Test Methods D 4442~~

13.1 *Moisture Content (M) or Final (Oven-Dry) Mass (m_0):*

13.1.1 If Test Methods D 4442 are used, the moisture content is calculated as follows:

⁵ Additional information on this test method may be obtained from TAPPI 258 om-06, Basic Density and Moisture Content of Pulpwood. Available from Technical Association of the Pulp and Paper Industry (TAPPI), 15 Technology Parkway South, Norcross, GA 30092, <http://www.tappi.org>.