

---

**Aeronavtika - Obločni dušilni odklopniki, enopolni, temperaturno kompenzirani, za naznačeni tok od 3 A do 25 A - 115 V izmenična napetost, 400 Hz konstantna frekvenca - 005. del: S polariziranim signalnim kontaktom - Standard za proizvod**

Aerospace series - Arc fault circuit breakers, single-pole, temperature compensated, rated current 3 A to 25 A - 115 V a.c. 400 Hz Constant Frequency - Part 005: With polarized signal contact - Product standard

Luft- und Raumfahrt - Arc Fault Schutzschalter, einpolig, Temperaturkompensiert, Nennströme von 3 A bis 25 A - 115 V a.c. 400 Hz Konstantfrequenz - Teil 005: Mit polarisiertem Signalkontakt - Produktnorm

Série aérospatiale - Disjoncteurs unipolaires à détection d'arc compensés en température, intensités nominales 3 A à 25 A - 115 V c.a. 400 Hz fréquence fixe - Partie 005: Avec contact de signalisation polarisé - Norme de produit

**Ta slovenski standard je istoveten z: EN 4838-005:2019**

**ICS:**

49.060	Letalska in vesoljska električna oprema in sistemi	Aerospace electric equipment and systems
--------	--	--

**SIST EN 4838-005:2019**

**en,fr,de**

**iTeh STANDARD PREVIEW**  
**(standards.iteh.ai)**

[SIST EN 4838-005:2019](#)

<https://standards.iteh.ai/catalog/standards/sist/62bf2add-f606-4929-9040-955f75c01f5b/sist-en-4838-005-2019>

EUROPEAN STANDARD

EN 4838-005

NORME EUROPÉENNE

EUROPÄISCHE NORM

June 2019

ICS 49.060

English Version

**Aerospace series - Arc fault circuit breakers, single-pole,  
temperature compensated, rated current 3 A to 25 A - 115  
V a.c. 400 Hz Constant Frequency - Part 005: With  
polarized signal contact - Product standard**

Série aérospatiale - Disjoncteurs unipolaires à  
détection d'arc compensés en température, intensités  
nominales 3 A à 25 A - 115 V c.a. 400 Hz fréquence fixe  
- Partie 005 : Avec contact de signalisation polarisé -  
Norme de produit

Luft- und Raumfahrt - Arc Fault Schutzschalter,  
einpolig, Temperaturkompensiert, Nennströme von 3  
A bis 25 A - 115 V a.c. 400 Hz Konstantfrequenz - Teil  
005: Mit polarisiertem Signalkontakt - Produktnorm

This European Standard was approved by CEN on 7 December 2017.

CEN members are bound to comply with the CEN/CENELEC Internal Regulations which stipulate the conditions for giving this European Standard the status of a national standard without any alteration. Up-to-date lists and bibliographical references concerning such national standards may be obtained on application to the CEN-CENELEC Management Centre or to any CEN member.

This European Standard exists in three official versions (English, French, German). A version in any other language made by translation under the responsibility of a CEN member into its own language and notified to the CEN-CENELEC Management Centre has the same status as the official versions.

CEN members are the national standards bodies of Austria, Belgium, Bulgaria, Croatia, Cyprus, Czech Republic, Denmark, Estonia, Finland, Former Yugoslav Republic of Macedonia, France, Germany, Greece, Hungary, Iceland, Ireland, Italy, Latvia, Lithuania, Luxembourg, Malta, Netherlands, Norway, Poland, Portugal, Romania, Serbia, Slovakia, Slovenia, Spain, Sweden, Switzerland, Turkey and United Kingdom.



EUROPEAN COMMITTEE FOR STANDARDIZATION  
COMITÉ EUROPÉEN DE NORMALISATION  
EUROPÄISCHES KOMITEE FÜR NORMUNG

**CEN-CENELEC Management Centre: Rue de la Science 23, B-1040 Brussels**

<b>Contents</b>	<b>Page</b>
<b>European foreword</b> .....	<b>3</b>
<b>1 Scope</b> .....	<b>4</b>
<b>2 Normative references</b> .....	<b>4</b>
<b>3 Terms and definitions</b> .....	<b>4</b>
<b>4 Dimension and mass</b> .....	<b>5</b>
<b>5 Characteristics</b> .....	<b>7</b>
<b>6 Designation</b> .....	<b>11</b>
<b>7 Rated current code</b> .....	<b>11</b>
<b>8 Delivery hardware codes</b> .....	<b>11</b>
<b>9 Marking</b> .....	<b>12</b>
<b>10 Technical specification</b> .....	<b>12</b>

**iTeh STANDARD PREVIEW**  
**(standards.iteh.ai)**

[SIST EN 4838-005:2019](#)

<https://standards.iteh.ai/catalog/standards/sist/62bf2add-f606-4929-9040-955f75c01f5b/sist-en-4838-005-2019>

## European foreword

This document (EN 4838-005:2019) has been prepared by the Aerospace and Defence Industries Association of Europe - Standardization (ASD-STAN).

After enquiries and votes carried out in accordance with the rules of this Association, this Standard has received the approval of the National Associations and the Official Services of the member countries of ASD, prior to its presentation to CEN.

This European Standard shall be given the status of a national standard, either by publication of an identical text or by endorsement, at the latest by December 2019, and conflicting national standards shall be withdrawn at the latest by December 2019.

Attention is drawn to the possibility that some of the elements of this document may be the subject of patent rights. CEN shall not be held responsible for identifying any or all such patent rights.

According to the CEN-CENELEC Internal Regulations, the national standards organizations of the following countries are bound to implement this European Standard: Austria, Belgium, Bulgaria, Croatia, Cyprus, Czech Republic, Denmark, Estonia, Finland, Former Yugoslav Republic of Macedonia, France, Germany, Greece, Hungary, Iceland, Ireland, Italy, Latvia, Lithuania, Luxembourg, Malta, Netherlands, Norway, Poland, Portugal, Romania, Serbia, Slovakia, Slovenia, Spain, Sweden, Switzerland, Turkey and the United Kingdom.

## iTeh STANDARD PREVIEW (standards.iteh.ai)

[SIST EN 4838-005:2019](https://standards.iteh.ai/catalog/standards/sist/62bf2add-f606-4929-9040-955f75c01f5b/sist-en-4838-005-2019)

<https://standards.iteh.ai/catalog/standards/sist/62bf2add-f606-4929-9040-955f75c01f5b/sist-en-4838-005-2019>

## EN 4838-005:2019 (E)

## 1 Scope

This document specifies the required characteristics for single-pole, arc fault circuit breakers rated currents from 3 A to 25 A, switching capacity  $65 I_n$ , for use in aircraft electrical systems. Their operating temperatures are between  $-40\text{ °C}$  to  $85\text{ °C}$  at a maximum altitude of  $Z = 15\ 000\text{ m}$ . The thermal protection is temperature compensated and operates between  $-55\text{ °C}$  and  $125\text{ °C}$ .

These circuit breaker are operated by a push-pull type single pushbutton (actuator), with delayed action "trip-free" tripping.

They will continue to function up to the short-circuit current.

## 2 Normative references

The following documents are referred to in the text in such a way that some or all of their content constitutes requirements of this document. For dated references, only the edition cited applies. For undated references, the latest edition of the referenced document (including any amendments) applies.

EN 3155-016, *Aerospace series — Electrical contacts used in elements of connection — Part 016: Contacts, electrical, male, type A, crimp, class S — Product standard*

EN 3841-100, *Aerospace series — Circuit breakers — Test Methods — Part 100: General*

EN 4838-001, *Aerospace series — Arc Fault Circuit breakers, single-pole, temperature compensated, rated current 3 A to 25 A — 115 Vac 400 Hz constant frequency — Part 001: Technical specification*

EN 6113, *Aerospace series — Circuit breakers, connecting and attachment hardware*

TR 6083, *Aerospace series — Cut-outs for installation of electrical components* <sup>1)</sup>

MIL-S-19500B, *Semiconductor Device, Diode, Type 1N969 (Navy)* <sup>2)</sup>

MIL-I-81969/1, *Installing and removal tools, connector electrical contact, Type III, Class 2, composition C* <sup>2)</sup>

MIL-I-81969/14, *Installing and removal tools, connector electrical contact, Type III, Class 2, composition B* <sup>2)</sup>

FED-STD-595B, *Colors used in Government Procurement*

## 3 Terms and definitions

For the purposes of this document, the terms and definitions given in EN 3841-100 apply.

ISO and IEC maintain terminological databases for use in standardization at the following addresses:

- IEC Electropedia: available at <http://www.electropedia.org/>
- ISO Online browsing platform: available at <http://www.iso.org/obp>

1) Published as ASD-STAN Technical Report at the date of publication of this European standard by AeroSpace and Defence industries Association of Europe - Standardization (ASD-STAN), <http://www.asd-stan.org>

2) Published by: DoD National (US) Mil. Department of Defense, <http://www.defenselink.mil/>

## 4 Dimension and mass

### 4.1 Dimensional characteristics

The circuit breakers do not have to correspond to the pictorial illustration, only the dimensions given shall be adhered to.

See Figure 1.

Dimensions are in millimetres with exception Terminal thread 8-32 UNC.

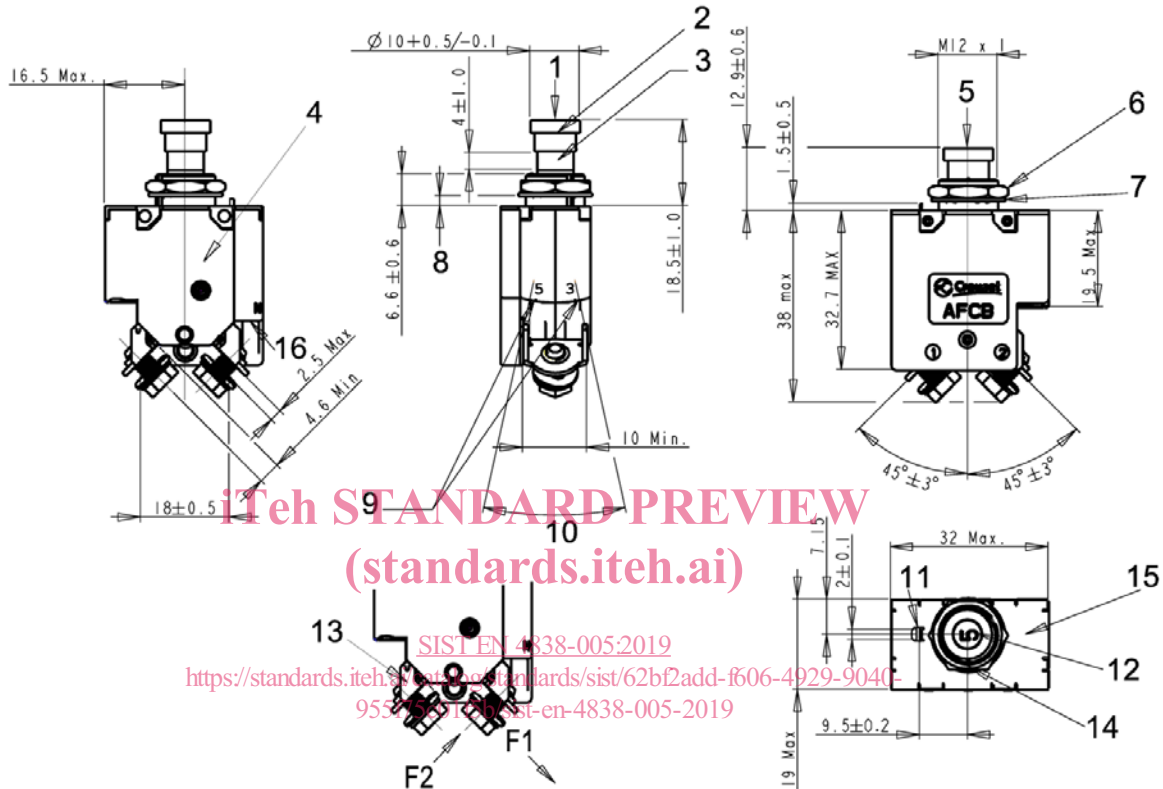

#### Key

- |  |   |
|--|---|
| 1 Push button released                             | 9 Gauge 20 connection pins according to EN 3155-016M2018 (terminals 3 and 5)                    |
| 2 Green colour according to FED-STD-595B No. 34090 | 10 Indicative value 25° (see Note)  |
| 3 White  | 11 Positioning lug in accordance with the panel cut-out, as per TR 6083C202. Neutral connection |
| 4 Marking area, see Clause 9.                      | 12 Rated current marking (white on green)   |
| 5 Push button pressed                              | 13 Terminals shape free   |
| 6 Attachment nut                                   | 14 LED indicator AlInGap 592 nm Amber colour 0,65 mm diameter                                   |
| 7 Lockwasher                                       | 15 Neutral via panel conductive metal plate interconnected to terminal 6                        |
| 8 1,0 to 3,0 max.                                  | 16 Gauge 20 connection pins according to EN 3155-016M2018 (terminal 6)                          |

F1 and F2: see EN 4838-001, Table 3.

NOTE Tools noted in 5.2.4 shall be applied without interfering with the terminal 2 connection. Even if the circuit breakers are grouped.

**Figure 1 — Configuration - Dimensions - Tolerances**

## EN 4838-005:2019 (E)

## 4.2 Electrical diagram

See Figure 2.

Push button released: CB is open, signal contact is closed.

Push button pressed: CB is closed, signal contact is open.

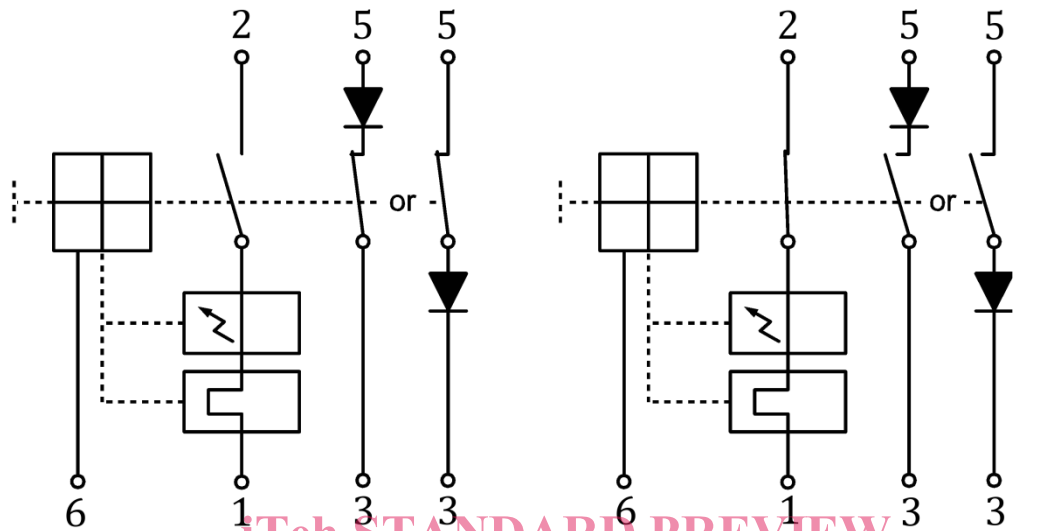

## Terminal No.:

1 and 2: Main contacts

1 = Supply and 2 = Load (see Table 1 of EN 4838-001)

3 and 5: Signal contacts

6: Neutral connection via Gauge 20 connection pins according to EN 3155-016M2018 (see Figure 1)

Figure 2 — Electrical diagram

## 4.3 Mass

Maximum mass: 35 g (including hardware delivery code A).

## 4.4 Panel mounting

Panel cut-out : The panel cut-out is in accordance with the designation TR 6083C202.

Spacing : 20 mm horizontal and 35 mm vertical from the centre of the mounting holes.

Panel thickness : 1 mm to 3 mm.

The metallic front plate of the breaker (mark 15 on Figure 1) is an electrical connection to neutral. For this purpose the panel mounting means must ensure a good electrical continuity to neutral.

In case of panel isolated from neutral a rear wire can be used to connect neutral to terminal 6 (see Figure 1).



## 5 Characteristics

### 5.1 Material, surface treatment

See EN 4838-001.

### 5.2 Mechanical characteristics

#### 5.2.1 Fasteners

See EN 6113.

#### 5.2.2 Recommended tightening torque of attaching nut for installation

(4,0 ± 0,25) N.m

#### 5.2.3 Recommended tightening torque of connection hardware for installation

(1,6 ± 0,1) N.m

#### 5.2.4 Recommended tools for contacts of auxiliary contact insertion and extraction

— plastic SAE-81969/14,

— metallic SAE-81969/1.

#### 5.2.5 Resistance to vibrations (standards.iteh.ai)

##### 5.2.5.1 Combined test: ambient temperature at 70 °C and vibrations

Sinusoidal: 10 g-PK, see EN 4838-001.

Random: 5,8 Grms, see EN 4838-001.

Low frequencies: 10 g-PK, see EN 4838-001.

##### 5.2.5.2 Combined test: ambient temperature at 85 °C, altitude and vibrations

Sinusoidal: 3 g-PK, see EN 4838-001.

#### 5.2.6 Resistance to shocks

50 g-PK, see EN 4838-001.

#### 5.2.7 Mechanical endurance

See Table 6.

### 5.3 Environment characteristics

#### 5.3.1 Humidity

See EN 4838-001.

#### 5.3.2 Corrosion

See EN 4838-001.