Turning tools with carbide tips — Internal tools

*Outils de tour à plaquettes en carbures métalliques — Outils
d'intérieur*

iTeh STANDARD PREVIEW
(standards.iteh.ai)

[ISO 514:2014](https://standards.iteh.ai/catalog/standards/sist/f69fdd24-3284-4832-93b4-3ecc3474df28/iso-514-2014)

<https://standards.iteh.ai/catalog/standards/sist/f69fdd24-3284-4832-93b4-3ecc3474df28/iso-514-2014>



iTeh STANDARD PREVIEW
(standards.iteh.ai)

ISO 514:2014

<https://standards.iteh.ai/catalog/standards/sist/f69fdd24-3284-4832-93b4-3ecc3474df28/iso-514-2014>



COPYRIGHT PROTECTED DOCUMENT

© ISO 2014

All rights reserved. Unless otherwise specified, no part of this publication may be reproduced or utilized otherwise in any form or by any means, electronic or mechanical, including photocopying, or posting on the internet or an intranet, without prior written permission. Permission can be requested from either ISO at the address below or ISO's member body in the country of the requester.

ISO copyright office
Case postale 56 • CH-1211 Geneva 20
Tel. + 41 22 749 01 11
Fax + 41 22 749 09 47
E-mail copyright@iso.org
Web www.iso.org

Published in Switzerland

Contents

Page

Foreword	iv
1 Scope	1
2 Normative references	1
3 Specifications	1
3.1 Types of internal tools.....	1
3.2 Shank sections.....	1
3.3 Overall lengths.....	1
3.4 Shape of the operative portion.....	2
4 Dimensions	2
Annex A (informative) Relationship between designations in ISO 514 and ISO 13399 series	4
Bibliography	5

iTeh STANDARD PREVIEW (standards.iteh.ai)

ISO 514:2014

<https://standards.iteh.ai/catalog/standards/sist/f69fdd24-3284-4832-93b4-3ecc3474df28/iso-514-2014>

Foreword

ISO (the International Organization for Standardization) is a worldwide federation of national standards bodies (ISO member bodies). The work of preparing International Standards is normally carried out through ISO technical committees. Each member body interested in a subject for which a technical committee has been established has the right to be represented on that committee. International organizations, governmental and non-governmental, in liaison with ISO, also take part in the work. ISO collaborates closely with the International Electrotechnical Commission (IEC) on all matters of electrotechnical standardization.

The procedures used to develop this document and those intended for its further maintenance are described in the ISO/IEC Directives, Part 1. In particular the different approval criteria needed for the different types of ISO documents should be noted. This document was drafted in accordance with the editorial rules of the ISO/IEC Directives, Part 2 (see www.iso.org/directives).

Attention is drawn to the possibility that some of the elements of this document may be the subject of patent rights. ISO shall not be held responsible for identifying any or all such patent rights. Details of any patent rights identified during the development of the document will be in the Introduction and/or on the ISO list of patent declarations received (see www.iso.org/patents).

Any trade name used in this document is information given for the convenience of users and does not constitute an endorsement.

For an explanation on the meaning of ISO specific terms and expressions related to conformity assessment, as well as information about ISO's adherence to the WTO principles in the Technical Barriers to Trade (TBT) see the following URL: Foreword - Supplementary information.

The committee responsible for this document is ISO/TC 29, *Small tools*, Subcommittee SC 9, *Tools with cutting edges made of hard cutting materials*.

This second edition cancels and replaces the first edition (ISO 514:1975), of which it constitutes a minor revision.

Turning tools with carbide tips — Internal tools

1 Scope

This International Standard specifies the types and dimensions of turning tools with carbide tips; it deals only with internal tools.

The shank sections and the inserts used are selected respectively from those defined in ISO 241 and ISO 242.

NOTE External tools and the definition of right-hand and left-hand tools are the subject of ISO 243; designation and marking are the subject of ISO 504.

2 Normative references

The following referenced documents are indispensable for the application of this document. For dated references, only the edition cited applies. For undated references, the latest edition of the referenced document (including any amendments) applies.

ISO 241, *Shanks for turning and planing tools — Shapes and dimensions of the section*

ISO 242, *Carbide tips for brazing on turning tools*

3 Specifications

3.1 Types of internal tools

Only two types of internal tools, considered to be those most generally used, are provided for; they are tool No. 8 and tool No. 9, which differ from each other only in the shape of the end of the operative portion.

Both types may be made either with a square shank or with a cylindrical shank, the front portion of the tool being of round section in both cases.

Dimension l shown in [Table 1](#) is the nominal length of the carbide tip, type A or C, selected from those specified in ISO 242; this dimension is equal to approximately $0,6 d$.

3.2 Shank sections

For the particular case of internal tools, only two types of sections are selected from among the various types specified in ISO 241:

- a) the square section $h = b$;
- b) the round section d .

3.3 Overall lengths

Only one range of overall lengths is specified, the length being a function of the diameter d .

The lengths are scaled approximately in the series of preferred numbers R 40/3 and are a practically linear expression in terms of d , no value departing by more than 15 mm from the value obtained with the formula:

$$10 d + 50 \text{ mm}$$

3.4 Shape of the operative portion

To permit the production of holes as small as possible, a bend of 15° is specified for the operative portion, with a dimension n virtually equal to $0,4 d$ and a cutting edge located at a distance equal to $0,2 d$ below the upper plane of the shank of the tool.

4 Dimensions

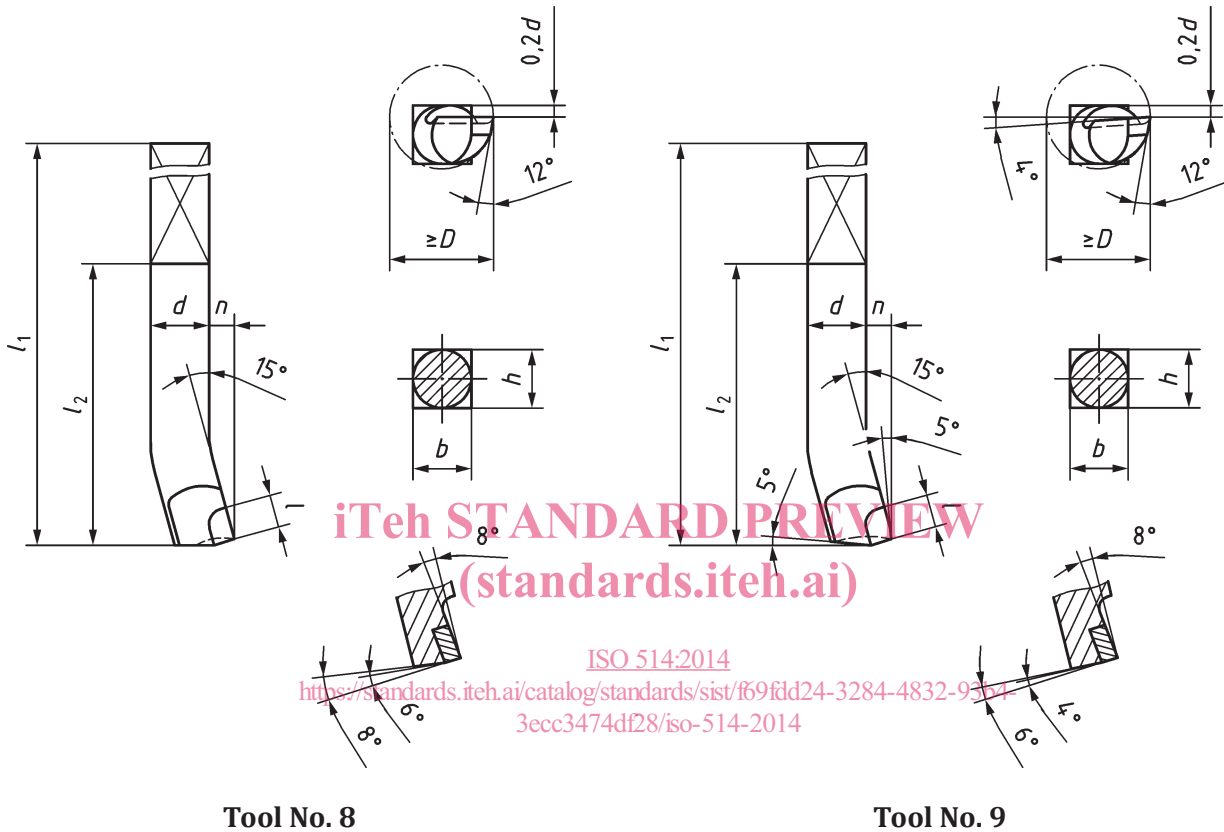

Figure 1 — Tool No. 8 and No. 9

Table 1 — Dimensions

Dimensions in millimetres

Tools Nos. 8 and 9 with square section							Tools Nos. 8 and 9 with round section				
$h \times b$	d	l_1^a	l_2	n	l	D_{\min}	d	l_1^a	n	l	D_{\min}
8 × 8	8	125	40	3	5	14	8	125	3	5	14
10 × 10	10	150	50	4	6	18	10	150	4	6	18
12 × 12	12	180	63	5	8	21	12	180	5	8	21
16 × 16	16	210	80	6	10	27	16	210	6	10	27
20 × 20	20	250	100	8	12	34	20	250	8	12	34
25 × 25	25	300	125	10	16	43	25	300	10	16	43
32 × 32	32	355	160	12	20	52	32	355	12	20	52

^a Tolerance on length l_1 : ${}^{+5}_0\%$.

NOTE 1 The dimension n , the angle of 15° , and in particular the cutting angle of 8° , are given only for information, but unless otherwise specified, they should be followed for tools delivered from stock.

NOTE 2 The choice between tips A and C is left to the manufacturer's discretion. The same applies to the method of attaching the tip to the tool.

iTeh STANDARD PREVIEW (standards.iteh.ai)

ISO 514:2014

<https://standards.iteh.ai/catalog/standards/sist/f69fdd24-3284-4832-93b4-3ecc3474df28/iso-514-2014>

Annex A (informative)

Relationship between designations in ISO 514 and ISO 13399 series

Table A.1 — Relationship between designations in ISO 514 and ISO 13399 series

Symbol in ISO 514	Reference in ISO 514	Property name in ISO 13399	Symbol in ISO 13399	Reference in ISO 13399
b	Clause 4, Table 1	shank width	B	ISO/TS 13399-3 ID-#: 71CF298751FCF
d	Clause 4, Table 1	connection diameter machine side	DCONMS	ISO/TS 13399-3 ID-#: 71EBDBF5060E6
D_{\min}	Clause 4, Table 1	minimum bore diameter	DMIN	ISO/TS 13399-3 ID-#: 71D07543367C5
h	Clause 4, Table 1	shank height	H	ISO/TS 13399-3 ID-#: 71CF29883E014
–	–	hand	HAND	ISO/TS 13399-3 ID-#: 71CF29872F0AB
l	Clause 4, Table 1	cutting edge length	L	ISO/TS 13399-2 ID-#: 71DD6C95DA49B
l_1	Clause 4, Table 1	functional length	LF	ISO/TS 13399-3 ID-#: 71CE7A9DFA23A
l_2	Clause 4, Table 1	reduced body diameter length	LDRED	ISO/TS 13399-3 ID-#: 727BE4DF14C62
n	Clause 4, Table 1	functional width 2	WF2	ISO/TS 13399-3 ID-#: 71D193F495583
15°	Clause 4; Figure 1	tool lead angle	PSIR	ISO/TS 13399-3 ID-#: 71D078F77616B

Bibliography

- [1] ISO 243, *Turning tools with carbide tips — External tools*
- [2] ISO 504, *Turning tools with carbide tips — Designation and marking*
- [3] ISO/TS 13399-2, *Cutting tool data representation and exchange — Part 2: Reference dictionary for the cutting items*
- [4] ISO/TS 13399-3, *Cutting tool data representation and exchange — Part 3: Reference dictionary for tool items*

iTeh STANDARD PREVIEW
(standards.iteh.ai)

[ISO 514:2014](#)

<https://standards.iteh.ai/catalog/standards/sist/f69fdd24-3284-4832-93b4-3ecc3474df28/iso-514-2014>