

---

---

**Dentistry — Oral care products —  
Manual interdental brushes**

*Médecine bucco-dentaire — Produits de soins bucco-dentaires —  
Brosses interdentaires manuelles*

**iTeh STANDARD PREVIEW  
(standards.iteh.ai)**

[ISO 16409:2016](https://standards.iteh.ai/catalog/standards/sist/6009435d-8358-4c93-94a3-0cad765744a9/iso-16409-2016)

<https://standards.iteh.ai/catalog/standards/sist/6009435d-8358-4c93-94a3-0cad765744a9/iso-16409-2016>



**iTeh STANDARD PREVIEW**  
**(standards.iteh.ai)**

ISO 16409:2016

<https://standards.iteh.ai/catalog/standards/sist/6009435d-8358-4c93-94a3-0cad765744a9/iso-16409-2016>



**COPYRIGHT PROTECTED DOCUMENT**

© ISO 2016, Published in Switzerland

All rights reserved. Unless otherwise specified, no part of this publication may be reproduced or utilized otherwise in any form or by any means, electronic or mechanical, including photocopying, or posting on the internet or an intranet, without prior written permission. Permission can be requested from either ISO at the address below or ISO's member body in the country of the requester.

ISO copyright office  
Ch. de Blandonnet 8 • CP 401  
CH-1214 Vernier, Geneva, Switzerland  
Tel. +41 22 749 01 11  
Fax +41 22 749 09 47  
[copyright@iso.org](mailto:copyright@iso.org)  
[www.iso.org](http://www.iso.org)

# Contents

	Page
<b>Foreword</b> .....	<b>iv</b>
<b>Introduction</b> .....	<b>v</b>
<b>1 Scope</b> .....	<b>1</b>
<b>2 Normative references</b> .....	<b>1</b>
<b>3 Terms and definitions</b> .....	<b>1</b>
<b>4 Classification</b> .....	<b>2</b>
<b>5 Requirements</b> .....	<b>2</b>
5.1 Defects or contamination.....	2
5.2 Brush size.....	2
5.3 Filament retention.....	3
5.4 Stem retention.....	3
5.5 Stem durability.....	3
<b>6 Sampling</b> .....	<b>3</b>
<b>7 Test methods</b> .....	<b>3</b>
7.1 General.....	3
7.2 Pass/fail criteria.....	3
7.3 Visual inspection.....	3
7.4 Passage hole diameter.....	3
7.4.1 Apparatus.....	3
7.4.2 Procedure.....	4
7.4.3 Evaluation.....	5
7.5 Filament retention.....	6
7.5.1 Apparatus.....	6
7.5.2 Procedure.....	6
7.5.3 Evaluation.....	6
7.6 Stem retention.....	6
7.6.1 Apparatus.....	6
7.6.2 Procedure.....	7
7.6.3 Evaluation.....	8
7.7 Stem durability.....	8
7.7.1 Apparatus.....	8
7.7.2 Procedure.....	10
7.7.3 Evaluation.....	11
<b>8 Test report</b> .....	<b>11</b>
<b>9 Accompanying information</b> .....	<b>11</b>
9.1 Manufacturer's instructions for use.....	11
9.2 Labelling on the package.....	11
<b>10 Packaging</b> .....	<b>12</b>

## Foreword

ISO (the International Organization for Standardization) is a worldwide federation of national standards bodies (ISO member bodies). The work of preparing International Standards is normally carried out through ISO technical committees. Each member body interested in a subject for which a technical committee has been established has the right to be represented on that committee. International organizations, governmental and non-governmental, in liaison with ISO, also take part in the work. ISO collaborates closely with the International Electrotechnical Commission (IEC) on all matters of electrotechnical standardization.

The procedures used to develop this document and those intended for its further maintenance are described in the ISO/IEC Directives, Part 1. In particular the different approval criteria needed for the different types of ISO documents should be noted. This document was drafted in accordance with the editorial rules of the ISO/IEC Directives, Part 2 (see [www.iso.org/directives](http://www.iso.org/directives)).

Attention is drawn to the possibility that some of the elements of this document may be the subject of patent rights. ISO shall not be held responsible for identifying any or all such patent rights. Details of any patent rights identified during the development of the document will be in the Introduction and/or on the ISO list of patent declarations received (see [www.iso.org/patents](http://www.iso.org/patents)).

Any trade name used in this document is information given for the convenience of users and does not constitute an endorsement.

For an explanation on the meaning of ISO specific terms and expressions related to conformity assessment, as well as information about ISO's adherence to the WTO principles in the Technical Barriers to Trade (TBT) see the following URL: [Foreword - Supplementary information](#).

The committee responsible for this document is ISO/TC 106, *Dentistry*, Subcommittee SC 7, *Oral care products*.

This second edition cancels and replaces the first edition (ISO 16409:2006), which has been technically revised with the following changes:

- addition of bigger brush size 8 in [Table 1](#);
- specification of number of test samples (eight manual interdental brushes) in [Clause 6](#);
- clarification of measuring procedure for the passage hole diameter for cylindrical and tapered brush heads.

It also incorporates the Amendment ISO 16409:2006/Amd 1:2010.

## Introduction

Manual interdental brushes are used for oral hygiene purposes intended to provide health benefits. Their main application purpose is mechanical plaque removal, primarily from the interdental regions.

**iTeh STANDARD PREVIEW**  
**(standards.iteh.ai)**

ISO 16409:2016

<https://standards.iteh.ai/catalog/standards/sist/6009435d-8358-4c93-94a3-0cad765744a9/iso-16409-2016>

**iTeh STANDARD PREVIEW**  
**(standards.iteh.ai)**

ISO 16409:2016

<https://standards.iteh.ai/catalog/standards/sist/6009435d-8358-4c93-94a3-0cad765744a9/iso-16409-2016>

# Dentistry — Oral care products — Manual interdental brushes

## 1 Scope

This International Standard specifies requirements and test methods for performance criteria for manual interdental brushes with a round cross-section of the brush head and consisting of a wired stem with inserted filaments. It also specifies the accompanying information such as manufacturer's instructions for use and labelling of the packaging.

Excluded are interdental brushes with a plastic core.

This International Standard is not applicable to powered interdental brushes, manual toothbrushes, dental floss, tapes, and strings and to interdental cleaners that do not include filaments.

## 2 Normative references

The following documents, in whole or in part, are normatively referenced in this document and are indispensable for its application. For dated references, only the edition cited applies. For undated references, the latest edition of the referenced document (including any amendments) applies.

ISO 1942, *Dentistry — Vocabulary*

## 3 Terms and definitions

ISO 16409:2016

<https://standards.iteh.ai/catalog/standards/sist/6009435d-8358-4c93-94a3->

For the purposes of this document, the terms and definitions given in ISO 1942 and the following apply.

### 3.1

#### manual interdental brush

hand-powered device composed of *filaments* (3.5) emanating radially from a *stem* (3.4) intended for cleaning of interdental surfaces

### 3.2

#### interdental brush head

part of *manual interdental brush* (3.1), which passes in and out of spaces between the teeth to clean the exposed surfaces

Note 1 to entry: The brush head may be fixed or removable, but is fixed during use.

### 3.3

#### interdental brush handle

part of *manual interdental brush* (3.1), which holds the *stem* (3.4) of the manual interdental brush

### 3.4

#### stem

central support structure of the manual *interdental brush head* (3.2), usually composed of twisted wire, which secures the *filaments* (3.5)

Note 1 to entry: The stem is either secured

- in the handle,
- in a connector, or
- fulfils the function of a handle itself.

3.5

**filament**

single strand, attached to the *stem* (3.4)

3.6

**stem retention force**

force required to remove the *stem* (3.4) from the *interdental brush handle* (3.3) holding it

3.7

**passage hole diameter**

minimum diameter of a hole through which a manual *interdental brush head* (3.2) can pass without *stem* (3.4) deformation

3.8

**brush size**

index of brush sizes determined by the *passage hole diameter* (3.7)

4 Classification

Manual interdental brushes shall be classified as follows:

- **Type 1:** replacement heads may be mounted into a handle;
- **Type 2:** the brush head is permanently affixed into the handle;
- **Type 3:** the stem fulfils the function of a handle.

STANDARD PREVIEW  
(standards.iteh.ai)

5 Requirements

ISO 16409:2016

5.1 Defects or contamination

standards.iteh.ai/catalog/standards/sist/6009435d-8358-4c93-94a3-0cad765744a9/iso-16409-2016

Manual interdental brushes including all supplied parts shall be free of apparent defects or contamination.

Test in accordance with 7.3.

5.2 Brush size

The brush size of manual interdental brushes shall be in accordance with Table 1.

Table 1 — Brush size of interdental brushes

Dimensions in millimetres

Brush size	Passage hole diameter
0	≤0,6
1	0,7 to 0,8
2	0,9 to 1,0
3	1,1 to 1,2
4	1,3 to 1,5
5	1,6 to 1,8
6	1,9 to 2,3
7	2,4 to 2,8
8	≥2,9

Determine the brush size of a manual interdental brush by using the passage hole diameter in accordance with 7.4



### 5.3 Filament retention

The filaments of manual interdental brushes shall not come off.

Test in accordance with [7.5](#).

### 5.4 Stem retention

The stem of manual interdental brushes of Type 1 and Type 2 shall withstand a removal force not less than 15 N.

Test in accordance with [7.6](#).

### 5.5 Stem durability

The stem of manual interdental brushes shall withstand the repeated bending for 20 cycles.

Test in accordance with [7.7](#).

## 6 Sampling

The manual interdental brushes used for testing shall be representative of manufactured manual interdental brushes and shall not be altered or adjusted in any way, except as needed to perform the tests.

Eight interdental brushes of each type shall be evaluated in each test. If it is necessary to repeat a test, another eight interdental brushes shall be tested.

ITEH STANDARD PREVIEW  
(standards.iteh.ai)

## 7 Test methods

ISO 16409:2016

### 7.1 General

<https://standards.iteh.ai/catalog/standards/sist/6009435d-8358-4c93-94a3-0cad765744a9/iso-16409-2016>

All tests shall be conducted using dry interdental brushes at the temperature of  $(23 \pm 5)$  °C and  $(50 \pm 10)$  % relative humidity.

### 7.2 Pass/fail criteria

For the filament retention, stem retention and stem durability tests, if none fail, the product set passes. If one manual interdental brush does not meet the minimum requirement, test another eight interdental brushes. If no more manual interdental brushes fail, the product passes. If a total of two or more manual interdental brushes of the sixteen fail, the product fails.

For the determination of the passage hole diameter, see [7.4](#).

### 7.3 Visual inspection

Visual inspection shall be performed with normal visual acuity without magnification.

### 7.4 Passage hole diameter

#### 7.4.1 Apparatus

**7.4.1.1 Measuring plate**, made of stainless steel or hardened steel with a thickness of  $(2,0 \pm 0,1)$  mm. The measuring plate has holes without sharp edges with diameters ranging from 0,6 mm up to 3,5 mm

in 0,1 mm increments and a total of 30 holes (see [Figure 1](#)). Tolerance of diameters of holes shall be from -0,02 mm to +0,02 mm.

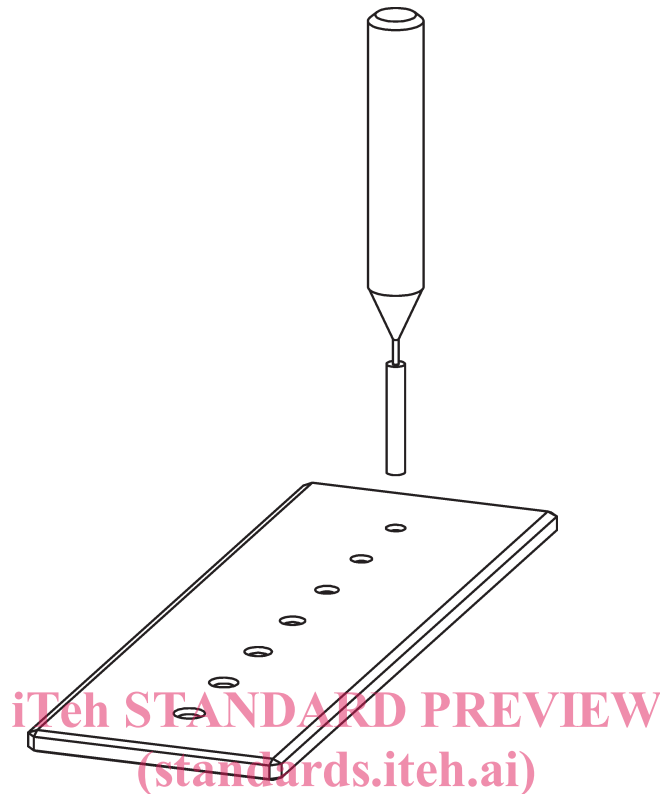

NOTE The design of the manual interdental brush head is given as an example; other designs are also possible.

<https://standards.iteh.ai/catalog/standards/sist/6009435d-8358-4c93-94a3-0cad765744a9/iso-16409-2016>

**Figure 1 — Measuring plate for the determination of passage hole diameter showing seven holes of the indicated 30 holes**

## 7.4.2 Procedure

### 7.4.2.1 Step 1

Select a hole on the measuring plate ([7.4.1.1](#)) such that the manual interdental brush head is expected to pass unobstructed through the hole.

### 7.4.2.2 Step 2

#### 7.4.2.2.1 Cylindrical brush heads

Insert the manual interdental brush into the hole by hand with a clinically relevant force until the entire manual interdental brush head passes through the hole. Then, pull out the manual interdental brush head from the hole. Repeat with all eight brush samples.

#### 7.4.2.2.2 Tapered brush heads

Insert the manual interdental brush into the hole by hand with a clinically relevant force until the entire manual interdental brush head passes through the hole. Then, pull out the manual interdental brush head from the hole. Repeat with all eight brush samples.

As an option, in order to describe the taper of the brush, insert the manual interdental brush into the hole by hand with a clinically relevant force until the tip of the manual interdental brush head passes

through the hole 1 mm beyond the surface of the measuring plate (see Figure 2). Then, pull out the manual interdental brush head from the hole. Repeat with all eight brush samples.

Dimensions in millimetres

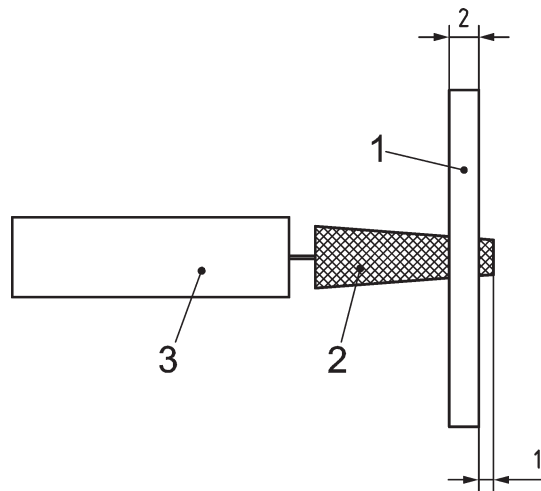

#### Key

- 1 measuring plate
- 2 tapered brush head
- 3 brush handle

## iTeh STANDARD PREVIEW

Figure 2 — Procedure for tapered brush heads

#### 7.4.2.3 Step 3

ISO 16409:2016

[https://standards.iteh.ai/catalog/standards/sist/6009435d-8358-4c93-94a3-](https://standards.iteh.ai/catalog/standards/sist/6009435d-8358-4c93-94a3-9017c5544892/iso-16409-2016)

When all eight samples can be inserted and removed from the hole without stem deformation, the sample set is judged to pass that hole. Otherwise, the sample set is judged not to pass that hole.

#### 7.4.2.4 Step 4

If the sample set is judged to pass the hole in step 3, repeat step 2 using the hole smaller by one increment. If the sample set does not pass the hole in step 3, repeat step 2 using the hole larger by one increment.

#### 7.4.2.5 Step 5

Stop the test when the smallest hole that allows passage without deformation of all samples in the set has been determined.

#### 7.4.2.6 Step 6

Record the diameter of the smallest hole that had been passed.

#### 7.4.2.7 Step 7, only for tapered brushes (optional)

Record the diameter of the second smallest hole (see 7.4.3) that had been passed.

#### 7.4.3 Evaluation

The diameter of the smallest hole that had been passed is the passage hole diameter. For tapered brushes, a one or two number range of sizes can be identified.