



Designation: D2570 – 08

# Standard Test Method for Simulated Service Corrosion Testing of Engine Coolants<sup>1</sup>

This standard is issued under the fixed designation D2570; the number immediately following the designation indicates the year of original adoption or, in the case of revision, the year of last revision. A number in parentheses indicates the year of last reapproval. A superscript epsilon ( $\epsilon$ ) indicates an editorial change since the last revision or reapproval.

## 1. Scope

1.1 This test method evaluates the effect of a circulating engine coolant on metal test specimens and automotive cooling system components under controlled, essentially isothermal laboratory conditions.

1.2 This test method specifies test material, cooling system components, type of coolant, and coolant flow conditions that are considered typical of current automotive use.

1.3 The values stated in foot-pound-second units are to be regarded as the standard. The values given in parentheses (SI units) are approximate equivalents for information only.

1.4 *This standard does not purport to address all of the safety concerns, if any, associated with its use. It is the responsibility of the user of this standard to establish appropriate safety and health practices and determine the applicability of regulatory limitations prior to use.* Specific precautionary statements are given in Section 6.

## 2. Referenced Documents

### 2.1 ASTM Standards:<sup>2</sup>

**D1121** Test Method for Reserve Alkalinity of Engine Coolants and Antirusts

**D1176** Practice for Sampling and Preparing Aqueous Solutions of Engine Coolants or Antirusts for Testing Purposes

**D1177** Test Method for Freezing Point of Aqueous Engine Coolants

**D1193** Specification for Reagent Water

**D1287** Test Method for pH of Engine Coolants and Antirusts

**D1384** Test Method for Corrosion Test for Engine Coolants in Glassware

**D2758** Test Method for Engine Coolants by Engine Dynamometer

**D2847** Practice for Testing Engine Coolants in Car and Light Truck Service

**D3306** Specification for Glycol Base Engine Coolant for Automobile and Light-Duty Service

**D3321** Test Method for Use of the Refractometer for Field Test Determination of the Freezing Point of Aqueous Engine Coolants

**D4985** Specification for Low Silicate Ethylene Glycol Base Engine Coolant for Heavy Duty Engines Requiring a Pre-Charge of Supplemental Coolant Additive (SCA)

**D6210** Specification for Fully-Formulated Glycol Base Engine Coolant for Heavy-Duty Engines

**D6660** Test Method for Freezing Point of Aqueous Ethylene Glycol Base Engine Coolants by Automatic Phase Transition Method

### 2.2 SAE Standard:<sup>3</sup>

**SAE J20e** Standard for Coolant System Hoses

### 2.3 ASTM Adjuncts:

Coolant reservoir (1 drawing)

Framework for test equipment (3 drawings and B/M)

## 3. Summary of Test Method

3.1 An engine coolant is circulated for 1064 h at 190°F (88°C) in a flow loop consisting of a metal reservoir, an automotive coolant pump, an automotive radiator, and connecting rubber hoses. Test specimens representative of engine cooling system metals are mounted inside the reservoir, which simulates an engine cylinder block. At the end of the test period, the corrosion-inhibiting properties of the coolant are determined by measuring the mass losses of the test specimens and by visual examination of the interior surfaces of the components.

## 4. Significance and Use

4.1 This test method, by a closer approach to engine cooling system conditions, provides better evaluation and selective screening of engine coolants than is possible from glassware testing (Test Method **D1384**). The improvement is achieved by controlled circulation of the coolant, by the use of automotive cooling system components, and by a greater ratio of metal surface area to coolant volume.

4.2 Although this test method provides improved discrimination, it cannot conclusively predict satisfactory corrosion

<sup>1</sup> This test method is under the jurisdiction of ASTM Committee **D15** on Engine Coolants and is the direct responsibility of Subcommittee **D15.09** on Simulated Service Tests.

Current edition approved Oct. 1, 2008. Published December 2008. Originally approved in 1966. Last previous edition approved in 2002 as D2570 - 96(2002) <sup>$\epsilon$ 1</sup>. DOI: 10.1520/D2570-08.

<sup>2</sup> For referenced ASTM standards, visit the ASTM website, www.astm.org, or contact ASTM Customer Service at service@astm.org. For *Annual Book of ASTM Standards* volume information, refer to the standard's Document Summary page on the ASTM website.

<sup>3</sup> Available from Society of Automotive Engineers, 400 Commonwealth Dr., Warrendale, PA 15096.

inhibition and service life. If greater assurance of satisfactory performance is desired, it should be obtained from full-scale engine tests (Test Method [D2758](#)) and from field testing in actual service (Practice [D2847](#)).

4.3 Significance and interpretation of the test and its limitations are discussed further in [Appendix X1](#).

4.4 If this test method is used as a qualification test for Specification [D3306](#) and Specification [D4985](#), the recommended components listed in Section 5 shall be used. If it is not being used for such qualification purposes, then suitable substitution components may be used, if agreed upon between the contracting parties.

## 5. Apparatus

5.1 *Reservoir*—An assembly drawing of this component<sup>4</sup> is shown in [Fig. 1](#). The material of construction, representing that of the engine cylinder block, shall be SAE G3500 Gray Iron for Automotive Castings.<sup>5</sup> Install a right angle fitting on the top of the reservoir for attachment of an air line. Install a shutoff valve in the air line to avoid backing up the solution into the pressure hose.

5.2 *Automotive Components*—These shall be those normally used with a 4, 6, or 8-cylinder automobile engine used in current automobiles in the United States, in the 1.6 to 5.0-L (98 to 305-in.<sup>3</sup>) range of piston displacement. General characteristics shall be as follows:

5.2.1 *Radiator*—Brass, GM part No. 3056740 (cross flow), with coolant recovery tank. An aluminum radiator, GM part No. 3093506, may be used subject to mutual agreement of the parties involved.

5.2.2 *Radiator Pressure Cap*—Normally open 12 to 15 psi (80 to 100 kPa), GM part No. 6410427.

5.2.3 *Coolant Pump*<sup>5</sup>—GM part No. 14033483 (aluminum matching front end cover). GM part No. 14033526 (aluminum provides back cover), coolant discharge parts and mounting for pump.

5.2.4 *Coolant Outlet*—GM part No. 14033198 (aluminum).

5.2.5 *Hoses*—Reinforced elastomer, meeting the requirements of [SAE J20e](#).<sup>6</sup>

5.2.6 *Hose Clamps*—Preferably worm-screw type (constant tension may be used).

5.2.7 *Hose Sight Tube*—A borosilicate glass sight tube shall be installed in the top radiator hose. The tube should have a slight bead on each end. (The primary purpose of the sight tube is to see that there is entrained air in the system.)

5.3 *Pipe Fittings*—The preferred material for the fittings required in the hose connections between pump discharge ports and reservoir inlet is malleable cast iron. A satisfactory alternative is steel.

<sup>4</sup> Detail drawings are available from ASTM International Headquarters. Order Adjunct No. ADJ257001. Original adjunct produced in 1982. Reservoirs of cast iron or cast aluminum, made in accordance with these drawings, may be obtained from Commercial Machine Service, 1099 Touhy Ave., Elk Grove Village, IL 60007, (847) 806-1901.

<sup>5</sup> Aluminum or iron may be used if mutually agreed upon between the parties involved.

<sup>6</sup> Gates “Vulco Straight” bulk-length radiator hose, Product Type 4178, has been found satisfactory. Equivalent radiator hoses may be used.

5.4 *Electric Motor*—1½ hp (1.1 kW) or larger, drip-proof or explosion-proof in accordance with local safety regulations.

5.5 *Pulleys and Drive Belt*—Sized to drive the pump at speed that will produce a flow rate of 20 to 25 gal/min (1.3 to 1.6 L/s) for the General Motors 173-in.<sup>3</sup> (2.8-L) V-6 engine. The flow rate may be determined by a flow measurement device<sup>7</sup> located between pump discharge and reservoir inlet, as indicated in [Fig. 2](#). The pressure drop between pump discharge and reservoir inlet, measured by the pressure gages shown in [Fig. 2](#), must be maintained when the flow measurement device is removed from the system. This can be done by substituting for the flow measurement device a variable-flow restriction, such as a valve, which can be adjusted to produce the same pressure drop as that measured across the flow measurement device at the specified flow rate.

5.6 *Electric Heater*—About 2000 W, either a hot plate<sup>8</sup> installed under the reservoir or a circumferential, metal-clad heater band<sup>9</sup> around the reservoir.

5.7 *Thermoregulator*—A suitable temperature regulator<sup>10</sup> shall be used to maintain the coolant temperature between the limits specified by [9.3](#). The sensing unit of the regulator shall be installed in an opening on the reservoir cover.

5.8 *Temperature Measuring Device*—An instrument<sup>11</sup> capable of indicating coolant temperature to the nearest 1°F or 1°C shall be installed in an opening on the reservoir cover.

5.9 *Framework*—A suitable framework shall be used to mount all the components as a unit.<sup>12</sup>

## 6. Safety Precautions

6.1 *Reservoir*—Protection against bursting shall be provided, either by a pressure-relief valve on the cover or by a safety enclosure.

6.2 *Pump Drive*—A safety guard for the coolant pump drive belt and pulleys shall be provided.

6.3 *Electrical*—Electrical circuits required for operation of motor, heater, and thermoregulator shall be installed with suitable precautions against electrical shock to operating personnel in the event of accidental spills of electrically conductive liquids.

6.4 *Thermal*—Protection of operating personnel against burns from exposed metal surfaces, especially those of the heater, shall be provided.

6.5 *Plumbing*—Protection of operating personnel against burns or scalds from hot fluid escaping from burst hoses or failed plumbing connections shall be provided.

<sup>7</sup> Fischer and Porter Series 10A2235A Ratosight Flow Rate Indicator, 4 to 50 gal/min (0.3 to 3.0 L/s), of bronze construction, has been found satisfactory. Equivalent flow measuring devices may be used.

<sup>8</sup> Chromalox No. ROPH-204 has been found satisfactory. Equivalent hot plates may be used.

<sup>9</sup> Chromalox No. HB-8415 has been found satisfactory. Equivalent heater bands may be used.

<sup>10</sup> Chromalox No. AR-2524P has been found satisfactory. Equivalent thermoregulators may be used.

<sup>11</sup> Fischer Scientific No. 15-076D and Weston No. 2261 dial-type thermometers have been found satisfactory. Equivalent thermometers may be used.

<sup>12</sup> Detail and assembly drawings of a suitable framework and arrangement of components thereon are available from ASTM International Headquarters. Order Adjunct No. ADJ257002. Original adjunct produced in 1982.

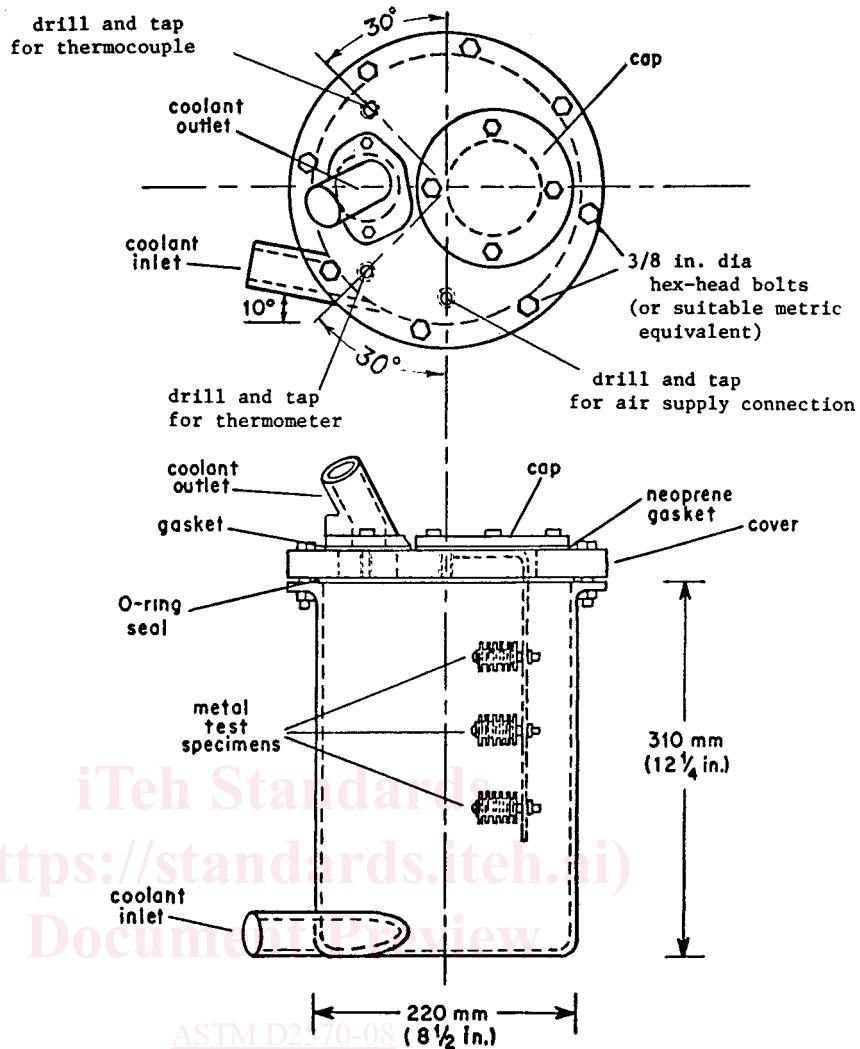

FIG. 1 Reservoir

## 7. Metal Test Specimens

NOTE 1—The specimens prescribed for this test method have been accepted by automobile manufacturers and are required for Specifications D3306 and D4985D3306D4985 qualification. Current production vehicles may have differing alloy. Therefore, specimens other than those designated in this test method may be used by mutual agreement of the parties involved.

7.1 The description, specification, preparation, cleaning, and weighing of the metal test specimens to be used in this test method are given in detail in Test Method D1384. However, the solid solder specimen allowed as an alternative in Test Method D1384 shall not be used in this test method, as it has been known to bend and contact an adjoining specimen. Specimens containing high lead solder, or low lead solder, or both, may be used subject to mutual agreement of the parties involved.

NOTE 2—The procedure for the cleaning of aluminum alloy coupons was changed in 1995 to eliminate the use of chromic acid, a recognized health hazard.

7.2 Arrangement—The metal test specimens shall be drilled through the center with a  $1/64$ -in. (6.8-mm) drill to accommodate a  $2\frac{1}{2}$ -in. (65-mm) 10–24 brass machine screw covered with a thin-walled insulating sleeve. Polytetrafluoroethylene tubing with a  $1/4$ -in. (6.4-mm) outside diameter and a wall thickness of  $1/64$  in. (0.4 mm) is satisfactory. The standard test “bundle” shall be assembled on the insulated screw with the specimens in the following order, starting from the screw head: copper, solder, brass, steel, cast iron, and cast aluminum. The specimens shall be separated by  $3/16$ -in. (5-mm) thick solid metal and insulating spacers having a  $1/64$ -in. (6.8-mm) inside diameter and a 7.16-in. (11-mm) outside diameter. Brass spacers shall be used between the copper, solder, and brass specimens, and steel spacers between the steel, cast iron, and cast aluminum specimens. Insulating spacers made from polytetrafluoroethylene shall be used between the screw head and the copper specimen, between the brass and steel specimens, and between the cast aluminum specimen and a brass nut. The nut shall be tightened firmly to ensure good electrical contact