

1097

# INTERNATIONAL STANDARD



# 1860

INTERNATIONAL ORGANIZATION FOR STANDARDIZATION • МЕЖДУНАРОДНАЯ ОРГАНИЗАЦИЯ ПО СТАНДАРТИЗАЦИИ • ORGANISATION INTERNATIONALE DE NORMALISATION

## Information processing — Precision reels for magnetic tape used in interchange instrumentation applications

*Traitement de l'information — Bobines de précision pour bandes magnétiques pour l'enregistrement de mesures*

**iTeh STANDARD PREVIEW**

Second edition — 1978-07-15

**(standards.iteh.ai)**

[ISO 1860:1978](#)

<https://standards.iteh.ai/catalog/standards/sist/96738284-ac5a-4c79-8ab6-e831b5c11971/iso-1860-1978>

UDC 681.327.64

Ref. No. ISO 1860-1978 (E)

**Descriptors:** data processing, bobbins, magnetic tapes, information interchange, instrumentation recording, specifications, dimensions.

Price based on 3 pages

## FOREWORD

ISO (the International Organization for Standardization) is a worldwide federation of national standards institutes (ISO member bodies). The work of developing International Standards is carried out through ISO technical committees. Every member body interested in a subject for which a technical committee has been set up has the right to be represented on that committee. International organizations, governmental and non-governmental, in liaison with ISO, also take part in the work.

Draft International Standards adopted by the technical committees are circulated to the member bodies for approval before their acceptance as International Standards by the ISO Council.

International Standard ISO 1860 was developed by Technical Committee ISO/TC 97, *Computers and information processing*.

This second edition was circulated to the member bodies in March 1977.

It has been approved by the member bodies of the following countries:

Australia	Italy	Spain
Belgium	Japan	Switzerland
Canada	Korea, Rep. of	United Kingdom
Czechoslovakia	Mexico	U.S.A.
France	Netherlands	Yugoslavia
Germany	Romania	
Hungary	South Africa, Rep. of	

No member body expressed disapproval of the document.

This second edition cancels and replaces the first edition (i.e. ISO 1860-1974).

An inter-related series of International Standards is in preparation in the field of instrumentation recording.

The series covers

- reels;
- unrecorded magnetic tape;
- recorded magnetic tape;
- recording methods.

This International Standard is part of that series and should be read accordingly.

## **iTeh STANDARD PREVIEW** **(standards.iteh.ai)**

[ISO 1860:1978](#)

<https://standards.iteh.ai/catalog/standards/sist/96738284-ac5a-4c79-8ab6-e831b5c11971/iso-1860-1978>

**iTeh STANDARD PREVIEW**  
**(standards.iteh.ai)**

ISO 1860:1978

<https://standards.iteh.ai/catalog/standards/sist/96738284-ae5a-4c79-8ab6-e831b5c11971/iso-1860-1978>

# Information processing — Precision reels for magnetic tape used in interchange instrumentation applications

## 1 SCOPE AND FIELD OF APPLICATION

This International Standard defines the recorder/reproducer interface or envelope requirements for precision reels with 76 mm (3 in) centre hole, designed for use in magnetic tape interchange instrumentation applications.

## 2 REEL DIMENSIONS

2.1 The dimensions of the reels shall be as specified in the figure and in tables 1, 2 and 3. The dimensions from which conversions are made are millimetres, and conversion is accomplished according to ISO 370, method A, except for dimensions  $A$  and  $M$ , which are converted by method B.

2.2 For measurement purposes, dimensions are referred to a reference plane (see figure) which coincides with the mounting surface of the reel. Reels and hubs shall be symmetrical to permit mounting from either side, and the specified dimensions must be achieved with each mounting surface taken in turn as the reference plane.

2.3 Reels shall be so constructed that any profile section taken through the centre axis of the reel will fall within the cross-hatched envelope of the figure; this includes lateral run-out of the flanges.

2.3.1 Bosses, ribs, or raised designs are permitted on the outside surfaces of the flanges provided that they do not extend beyond the cross-hatched envelope when the reel is rotated around its centre axis.

2.3.2 The surface of the two flanges, considered between diameters  $L$  and  $B$ , shall lie between the planes defined respectively by dimensions  $H_1$  and  $J_1$  for the flange closest to the reference plane, and between  $H_2$  and  $J_2$  for the other flange.

2.3.3 Between diameters  $A$  and  $L$  the outside surfaces of the reel, including any flange fastening device employed, shall not extend beyond the surfaces defined by dimension  $M$  (see figure).

2.3.4 The hub surfaces defined by dimensions  $M$  and  $K$  shall be parallel within 0,000 4 mm per millimetre (0.000 4 in per inch). The hub surface defined by diameter  $C$  shall be square to the reference plane within 0,001 5 mm per millimetre (0.001 5 in per inch).

2.4 Flanges may have holes of convenient size, shape and location to facilitate threading of the tape; these holes are optional.

2.5 The inside cylindrical surface of the centre hole (diameter  $A$ ) shall be coaxial with the outside cylindrical surface of the hub (diameter  $C$ ) within 0,05 mm (0.002 in) TIR; i.e. the deviation of the centre of diameter  $A$  with respect to the centre of diameter  $C$  shall not exceed 0,025 mm (0.001 in).

2.6 The outside diameter of the flanges (diameter  $B$ ) shall be coaxial with the centre hole of the hub (diameter  $A$ ) within 0,4 mm (0.015 in) TIR; i.e. the deviation of the centre of diameter  $B$  with respect to the centre of diameter  $A$  shall not exceed 0,2 mm (0.008 in).

2.7 The maximum taper (change of radius) of the outside cylindrical surface of the hub measured over the length included between the inner surfaces of the flanges shall be as follows :

Tape width	Maximum taper
6,30 mm (0.25 in)	0,02 mm (0.000 8 in)
12,7 mm (0.5 in)	0,02 mm (0.000 8 in)
25,4 mm (1 in)	0,02 mm (0.000 8 in)
50,8 mm (2 in)	0,04 mm (0.001 6 in)

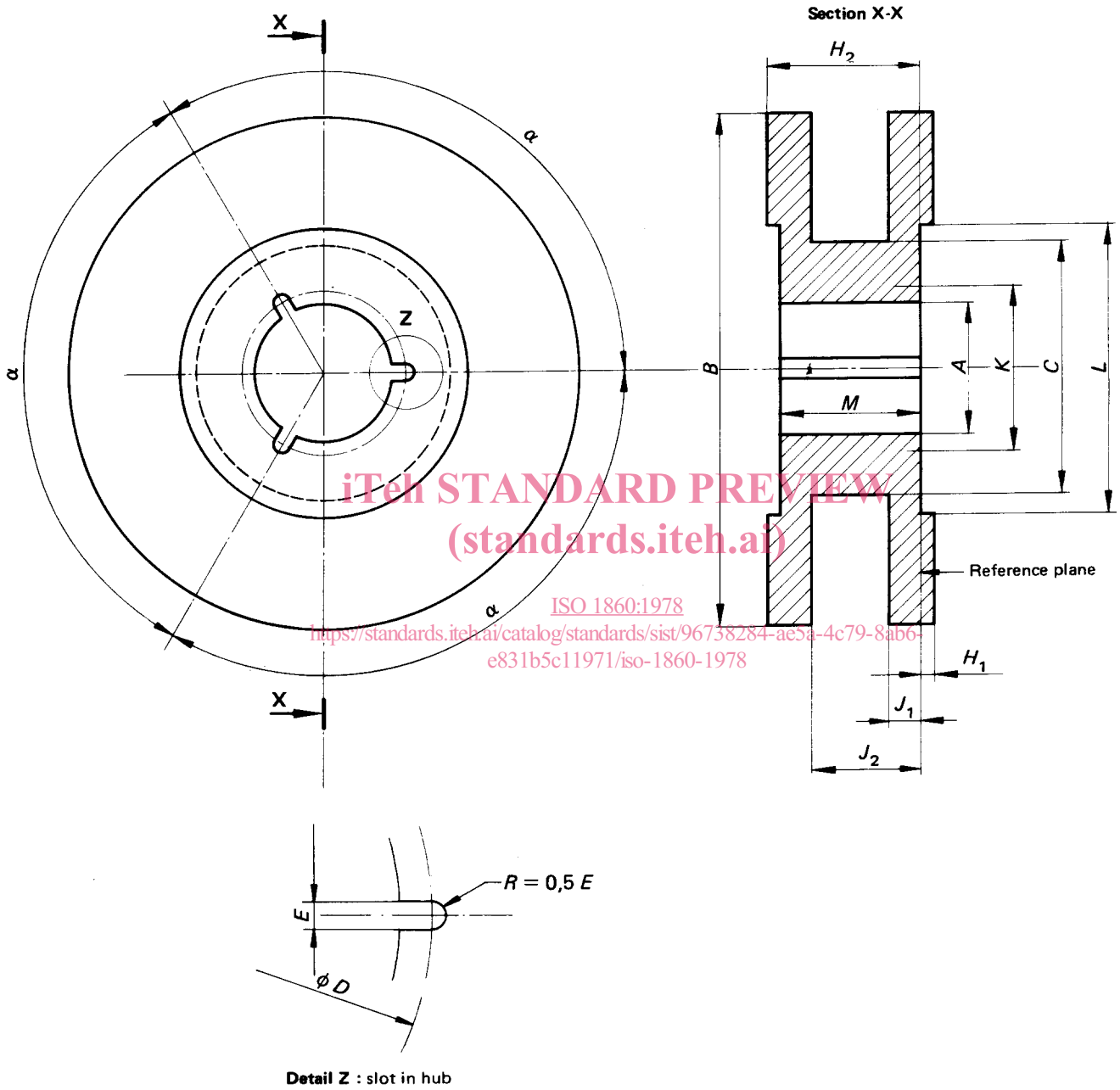

NOTE – Dimensions  $J_1$ ,  $H_1$ ,  $J_2$  and  $H_2$  define the envelope within which the flanges must lie and do not define the thickness of the flanges.

FIGURE – Dimensions of the reels

TABLE 1 – Reel dimensions

Dimension	millimetres	inches	angular degrees
A	76,3	3.003 9	
	76,2	3.000 0	
C*	114,6	4.512	
	114,0	4.488	
D	82,6	3.252 0	
	82,5	3.248 0	
E	5,72	0.225 2	
	5,56	0.218 9	
H <sub>1</sub>	0,64 max.	0.025 max.	
J <sub>1</sub>	2,50 max.	0.098 max.	
K	91,5 min.	3.602 min.	
L	152,4 min.	6.000 min.	
α			120,1 119,9

\* Exclusive of friction rings.

TABLE 3 – Reel widths

Standard tape width*		Dimension M			
mm	in	mm		in	
		max.	min.	max.	min.
6,30	0,25	11,81	11,66	0.464 9	0.459 1
12,70	0,50	18,16	18,01	0.714 9	0.709 1
25,40	1,00	30,86	30,71	1.214 9	1.209 1
50,80	2,00	56,26	56,11	2.214 9	2.209 1

\* The values given in this column are nominal. See ISO 1859, *Information processing – Unrecorded magnetic tapes for interchange instrumentation applications – General dimensional requirements.*

NOTE – Dimensions H<sub>2</sub> and J<sub>2</sub> are determined by the following formulae :

$$H_2 \text{ max.} = M \text{ max.} + H_1 \text{ max.}$$

$$J_2 \text{ min.} = M \text{ min.} - J_1 \text{ max.}$$

**iTeh STANDARD PREVIEW**  
(standards.iteh.ai)

TABLE 2 – Reel diameters

Dimension B	
mm	in
203,5	8.012
202,9	7.988
267,0	10.512
266,4	10.488
355,9	14.012
355,3	13.988
381,3	15.012
380,7	14.988
406,7	16.012
406,1	15.988

ISO 1860:1978

[https://standards.iteh.ai/catalog/standards/sist/96738284-ae5a-4c79-8ab6-](https://standards.iteh.ai/catalog/standards/sist/96738284-ae5a-4c79-8ab6-e831b5c11971/iso-1860-1978)

[e831b5c11971/iso-1860-1978](https://standards.iteh.ai/catalog/standards/sist/96738284-ae5a-4c79-8ab6-e831b5c11971/iso-1860-1978)

**iTeh STANDARD PREVIEW**  
**(standards.iteh.ai)**

ISO 1860:1978

<https://standards.iteh.ai/catalog/standards/sist/96738284-ae5a-4c79-8ab6-e831b5c11971/iso-1860-1978>