



# Standard Test Method for Smoke Obscuration of Insulating Materials Contained in Electrical or Optical Fiber Cables When Burning in a Vertical Cable Tray Configuration<sup>1</sup>

This standard is issued under the fixed designation D 5424; the number immediately following the designation indicates the year of original adoption or, in the case of revision, the year of last revision. A number in parentheses indicates the year of last reapproval. A superscript epsilon ( $\epsilon$ ) indicates an editorial change since the last revision or reapproval.

## 1. Scope

1.1 This is a fire-test-response standard.

1.2 This test method provides a means to measure the smoke obscuration resulting from burning electrical insulating materials contained in electrical or optical fiber cables when the cable specimens, excluding accessories, are subjected to a specified flaming ignition source and burn freely under well ventilated conditions.

1.3 This test method provides two different protocols for exposing the materials, when made into cable specimens, to an ignition source (approximately 20 kW), for a 20 min test duration. Use it to determine the flame propagation and smoke release characteristics of the materials contained in single and multiconductor electrical or optical fiber cables designed for use in cable trays.

1.4 This test method does not provide information on the fire performance of electrical or optical fiber cables in fire conditions other than the ones specifically used in this test method nor does it measure the contribution of the cables to a developing fire condition.

1.5 Data describing the burning behavior from ignition to the end of the test are obtained.

1.6 The production of light obscuring smoke is measured.

1.7 The burning behavior is documented visually, by photographic or video recordings, or both.

1.8 The test equipment is suitable for making other, optional, measurements, including the rate of heat release of the burning specimen, by an oxygen consumption technique and weight loss.

1.9 Another set of optional measurements are the concentrations of certain toxic gas species in the combustion gases.

1.10 The values stated in SI units are to be regarded as the standard (see IEEE/ASTM SI 10).

1.11 *This standard measures and describes the response of materials, products, or assemblies to heat and flame under controlled conditions, but does not by itself incorporate all*

*factors required for fire hazard or fire risk assessment of the materials, products or assemblies under actual fire conditions.*

1.12 Fire testing of products and materials is inherently hazardous. Employ adequate safeguards for personnel and property in conducting these tests.

1.13 *This standard does not purport to address all of the safety concerns, if any, associated with its use. It is the responsibility of the user of this standard to establish appropriate safety and health practices and determine the applicability of regulatory limitations prior to use.*

## 2. Referenced Documents

### 2.1 ASTM Standards:

D 1835 Specification for Liquefied Petroleum (LP) Gases<sup>2</sup>

E 84 Test Method for Surface Burning Characteristics of Building Materials<sup>3</sup>

E 176 Terminology of Fire Standards<sup>3</sup>

E 800 Guide for Measurement of Gases Present or Generated During Fires<sup>3</sup>

E 1354 Test Method for Heat and Visible Smoke Release Rates for Materials and Products Using an Oxygen Consumption Calorimeter<sup>3</sup>

IEEE/ASTM SI 10 Standard for Use of the International System of Units (SI): The Modern Metric System<sup>4</sup>

### 2.2 NFPA Standard:<sup>5</sup>

ANSI/NFPA 70-1990, National Electrical Code—1990, National Fire Protection Association<sup>5</sup>

### 2.3 Underwriters Laboratories Standards:<sup>6</sup>

UL 1056: Fire Test of Upholstered Furniture, Underwriters Laboratories, 1989

UL 1581: Reference Standard for Electrical Wires, Cables, and Flexible Cords, March 6, 1987, Underwriters Laboratories, Inc., ANSI/UL 1581-1985

UL 1685: Standard Vertical Tray Fire Propagation and

<sup>2</sup> Annual Book of ASTM Standards, Vol 05.01.

<sup>3</sup> Annual Book of ASTM Standards, Vol 04.07.

<sup>4</sup> Annual Book of ASTM Standards, Vol 14.02.

<sup>5</sup> Available from National Fire Protection Association, Batterymarch Park, Quincy, MA 02269.

<sup>6</sup> Available from Underwriters Laboratories, Inc., 333 Pfingsten Rd., Northbrook, IL 60062.

<sup>1</sup> This test method is under the jurisdiction of ASTM Committee D-9 on Electrical and Electronic Insulating Materials and is the direct responsibility of Subcommittee D09.21 on Fire Performance Standards.

Current edition approved Oct. 10, 1999. Published December 1999. Originally published as D 5424 – 93. Last previous edition D 5424 – 98.

Smoke Release Test for Electrical and Optical Fiber Cables, Underwriters Laboratories, Inc., January 27, 1992

2.4 *Canadian Standards Association Standards:*<sup>7</sup>

CSA Standard FT-4, Vertical Flame Tests: Cables in Cable Trays, Section 4.11.4 in C22.2 No. 0.3-M1985, Test Methods for Electrical Wires and Cables

2.5 *IEEE Standards:*<sup>8</sup>

IEEE 1202-1991: Standard for Flame Testing of Cables for Use in Cable Tray in Industrial and Commercial Occupancies, May 29, 1991.

2.6 *Other Standards:*

CA Technical Bulletin 133, Flammability Test Procedure for Seating Furniture for Use in Public Occupancies, January, 1991<sup>9</sup>

Nordtest Method NT Fire 032, Upholstered Furniture: Burning Behavior—Full Scale Test<sup>10</sup>

### 3. Terminology

3.1 For definitions of terms used in this test method and associated with fire issues, refer to Terminology E 176.

3.2 *Definitions of Terms Specific to This Standard:*

3.2.1 *sample, n*—an amount of the cable type and construction to be tested, which is representative of the product for test.

3.2.2 *specimen, n*—the individual length of cable, or cable bundle, to be placed in the cable tray, which is representative of the product to be tested.

### 4. Summary of Test Method

4.1 This fire-test-response standard determines a number of fire-test-response characteristics associated with smoke obscuration resulting from burning the materials insulating full-scale specimens of electrical or optical fiber cables located in a vertical cable tray and ignited with a propane gas burner. This test method is also suitable for making other, optional measurements, including rates of heat release, total amounts of heat released, rates and concentrations of carbon oxides released and rates and amounts of mass of the specimen lost (see Appendix X2). Further optional measurements are also possible.

4.2 The vertical cable tray that holds the specimen is located in an enclosure of specified dimensions.

4.3 A hood, connected to a duct, is located above the fire enclosure. Smoke release instrumentation is placed in the duct. Heat and gas analysis release instrumentation (optional) is also placed in the duct.

4.4 Two different test procedures are specified, which differ in the burner used and in the electrical or optical fiber cable loading. These reflect details of three existing test methods: UL 1581 (protocol A) and CSA Standard FT-4 in C22.2 No. 0.3-M1985 or IEEE 1202 (protocol B) and UL 1685 (both protocols).

<sup>7</sup> Available from Canadian Standards Association, 178 Rexdale Blvd., Rexdale, Ontario, Canada, M9W 1R3.

<sup>8</sup> Available from Institute of Electrical and Electronic Engineers, 345 East 47th St., New York, NY 10017.

<sup>9</sup> Available from Bureau of Home Furnishings and Thermal Insulation, State of California, Department of Consumer Affairs, 3485 Orange Grove Ave., North Highlands, CA 95660-5595.

<sup>10</sup> Available from Nordtest, P.O. Box 22, SF-00341, Helsingfore, Finland, 1987.

### 5. Significance and Use

5.1 This test method provides a means to measure a variety of fire-test-response characteristics associated with smoke obscuration and resulting from burning the electrical insulating materials contained in electrical or optical fiber cables. The specimens are allowed to burn freely under well ventilated conditions after ignition by means of a propane gas burner.

5.2 Smoke obscuration quantifies the visibility in fires.

5.3 This test method is also suitable for measuring the rate of heat release as an optional measurement. The rate of heat release often serves as an indication of the intensity of the fire generated.

5.4 Other optional fire-test-response characteristics that are measurable by this test method are useful to make decisions on fire safety. The most important gaseous components of smoke are the carbon oxides, present in all fires. They are major indicators of the toxicity of the atmosphere and of the completeness of combustion and are often used as part of fire hazard assessment calculations and to improve the accuracy of heat release measurements. Other toxic gases, which are specific to certain materials, are less crucial for determining combustion completeness.

5.5 *Test Limitations:*

5.5.1 The fire-test-response characteristics measured in this test method are a representation of the manner in which the specimens tested behave under certain specific conditions. Do not assume they are representative of a generic fire performance of the materials tested when made into cables of the construction under consideration.

5.5.2 In particular, it is unlikely that this test method is an adequate representation of the fire behavior of cables in confined spaces, without abundant circulation of air.

5.5.3 This is an intermediate-scale test, and the predictability of its results to large scale fires has not been determined. Some information exists to suggest that it has been validated against some large-scale scenarios.

### 6. Apparatus

6.1 *Enclosure:*

6.1.1 The enclosure in which the specimen is tested is shown in Fig. 1.

6.1.2 The enclosure has a floor area of  $2.44 \text{ m} \pm 25 \text{ mm}$  by  $2.44 \text{ m} \pm 25 \text{ mm}$ , with a height of  $3.35 \text{ m} \pm 25 \text{ mm}$  ( $8 \text{ ft} \pm 1 \text{ in.}$  by  $8 \text{ ft} \pm 1 \text{ in.}$  by  $11 \text{ ft} \pm 1 \text{ in.}$  high). On top of the walls there is a pyramidal collection hood with a collection box.

6.1.2.1 Other enclosure sizes, such as  $2.4 \text{ by } 2.4 \text{ by } 2.4 \text{ m}$  ( $8 \text{ by } 8 \text{ by } 8 \text{ ft}$ ) or the  $3 \text{ m}$  cube are permitted, provided that the internal volume of the enclosure, exclusive of the pyramidal hood, ranges between  $14.5 \text{ m}^3$  ( $512 \text{ ft}^3$ ) and  $36 \text{ m}^3$  ( $1272 \text{ ft}^3$ ), the floor area ranges between  $6 \text{ m}^2$  ( $64 \text{ ft}^2$ ) and  $9 \text{ m}^2$  ( $97 \text{ ft}^2$ ), and the maximum air movement within the enclosure complies with 6.1.10 (Note 1).

NOTE 1—There is, as yet, not enough information as to the equivalence on smoke release between the various facilities. Further work needs to be done to confirm this.

6.1.2.2 In case of disputes, the referee method are the tests conducted using the enclosure in 6.1.2.

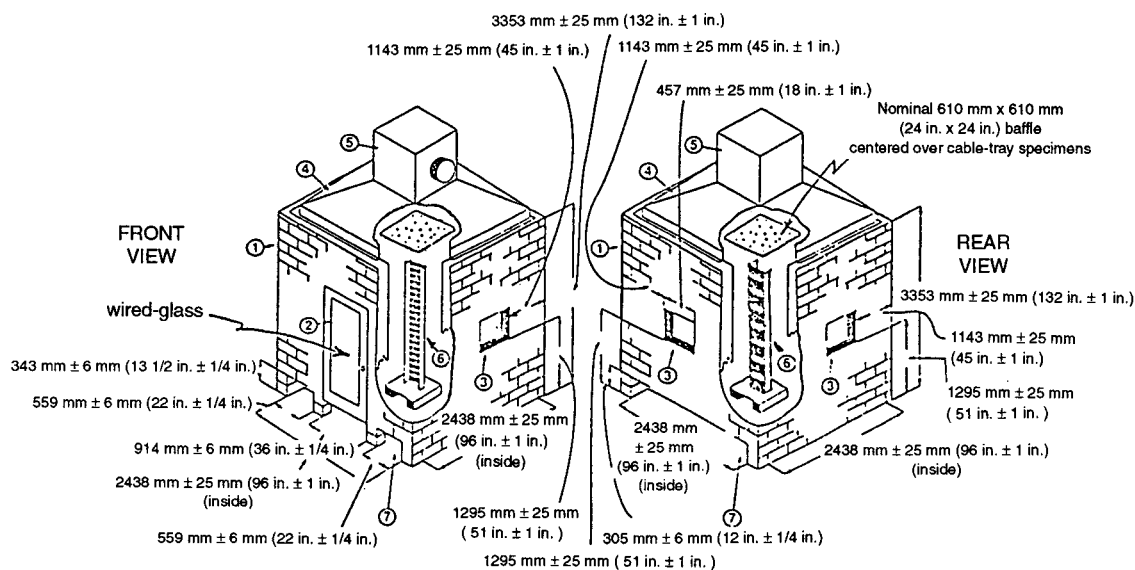

1. Enclosure: an acceptable construction consists of concrete masonry blocks, laid up with mortar, nominally 203 mm high by 406 mm wide by 152 mm thick (8 by 16 by 6 in.).
2. Wired-glass door, for access and observation. The overall size of the door is 2.1 m high and 0.9 m wide (84 by 36 in.).
3. Steel-framed wired-glass observation windows, 457 mm (18 in.) per side (optional).
4. Truncated-pyramid stainless steel hood, with each side sloped 40°.
5. Cubical collection box, 914 mm (36 in.) per side, with exhaust duct centered on one side.
6. Cable tray, mounted vertically in the center of the enclosure. Tray base (stand) is optional.
7. Air intake openings.

FIG. 1 Cable Test Enclosure

6.1.3 Walls—The maximum conductive heat flux loss of the walls of the structure is 6.8 W/(m<sup>2</sup>K) (30 Btu/h-ft<sup>2</sup>), based upon an inside wall temperature of 38°C (100°F) and an outside air temperature of 24°C (75°F). Paint the interior surface of the walls flat black. Any materials of construction that meet the preceding requirements are acceptable. Two examples of acceptable construction materials are nominally 152 mm (6 in.) thick concrete masonry blocks (density: 1700 kg m<sup>-3</sup>(106 lb ft<sup>-3</sup>) and thermal conductivity nominally  $k = 1.75$  W/(m K), at 21°C; 12.13 Btu in./ft<sup>2</sup> h°F, at 70°F) or nominally 13 mm (0.5 in.) gypsum board, with 89 ± 6 mm (3.5 ± 0.25 in.) of standard fiberglass insulation, with an  $R$  value of 1.94 m<sup>2</sup> K/W (which corresponds in practical units to an  $R$  value of 11 h ft<sup>2</sup>°F/Btu). Windows for observation of the fire test are allowed in the walls; ensure that the total area of the windows does not exceed 1.86 m<sup>2</sup>(20 ft<sup>2</sup>).

6.1.3.1 Select materials of construction which can withstand the high temperatures and presence of open flame within the test enclosure and duct.

6.1.4 Provide air intakes at the base of two opposite walls, one of which contains the access door. Ensure that the total cross sectional area of the air intakes is 1.45 ± 0.03 m<sup>4</sup>(2250 ± 50 in.<sup>2</sup>), and that the intake areas are divided approximately equally. Fig. 1 shows dimensions for the air intakes installed in the walls. Air intakes are not permitted in either of the other two walls.

6.1.5 Construct a door with wired glass and locate it as shown in Fig. 1. The door is 900 ± 25 mm wide and 2100 ± 25 mm high (35 ± 1 in. by 83 ± 1 in.), with an overall conductive

heat flux loss no greater than that of the walls, that is, 6.8 W/(m<sup>2</sup>K) (30 Btu/h-ft<sup>2</sup>). A steel framed wired glass door will meet these requirements. Adequately seal the sides and the top of the door to prevent drafts.

6.1.6 Construct a truncated pyramid stainless steel hood, formed as shown in Fig. 1, and locate it on top of the enclosure walls. Make the slope on each side of the hood 40°. Form a seal between the hood and the walls; a compressible inorganic batting as gasket is suitable.

6.1.7 Insulate the exterior of the hood to make an overall conductive heat loss no greater than that of the walls.

6.1.8 Locate a cubical stainless steel collection box (914 ± 25 mm (36 ± 1 in.) per side) on top of the exhaust hood, with a nominal 406 ± 25 mm (16 ± 1 in.) diameter stainless steel pipe exhaust duct centered in one side.

6.1.9 Install the exhaust duct horizontally and connect it to the plenum of the hood.

6.1.10 Ensure that the maximum air movement within the enclosure, with only the intake and exhaust openings open, the exhaust fan on, and the burner off, does not exceed 1 m/s (3.3 ft/s), as measured by a vane-type anemometer in the following areas: (1) at the floor level where the burner is positioned during the test, and (2) at 1.50 ± 0.05 m (4.9 ft ± 2 in.) above the enclosure floor, where the cable tray is positioned during the test.

6.1.11 Construct a square 610 ± 25-mm (24 ± 1-in.) baffle, centered over the cable tray. An acceptable height is 300 to 400 mm (12 to 15 in.) above the tray.

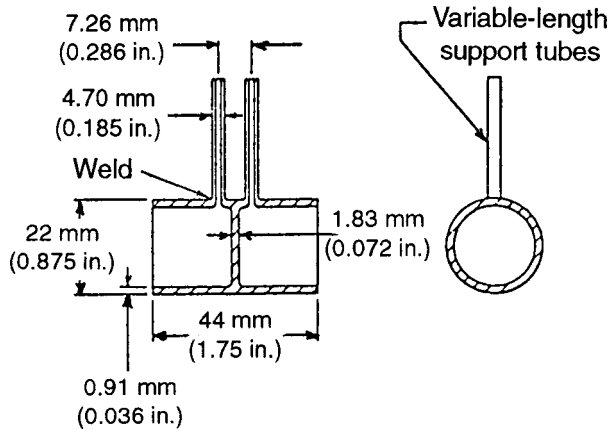

FIG. 2 Bidirectional Probe

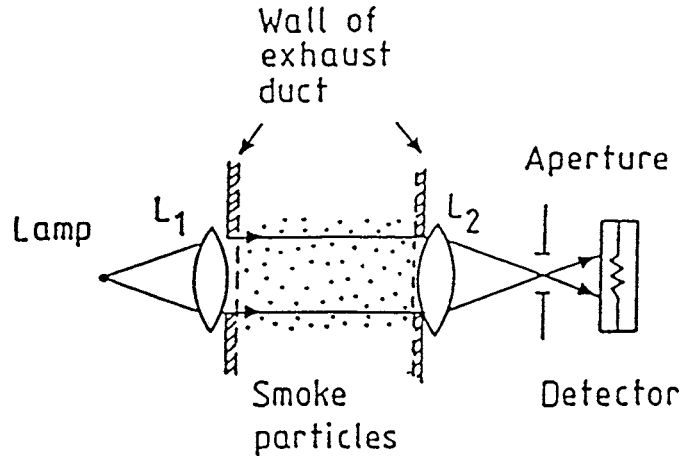

FIG. 3 Optical System

6.1.12 Construct a collection-exhaust system consisting of a blower, steel hood, duct, bidirectional probe, thermocouple(s), oxygen measurement system (optional), smoke obscuration measurement system, and gas analysis system (optional). Ensure that the system for collecting the combustion products has the capacity and is designed in such a way that all of the combustion products leaving the burning specimen are collected. Make the exhaust system capacity at least  $2.7 \text{ m}^3 \text{ s}^{-1}$  at normal pressure and at a temperature of  $25 \pm 2^\circ\text{C}$ . Construct the collection-exhaust system as explained in Annex A2 and Annex A3.

6.2 Exhaust Collection System:

6.2.1 Construct the exhaust collection system with the following minimal requirements: a blower, steel hood, duct, bidirectional probe, thermocouple(s) and a smoke obscuration measurement system (white light photocell lamp/detector or laser). Construct the exhaust collection system as explained in Annex A2 and Annex A3.

6.2.2 Ensure that the system for collecting the combustion products has sufficient exhaust capacity and is designed in such a way that all of the combustion products leaving the burning specimen are collected. Design the capacity of the evacuation system such that it will exhaust minimally all combustion gases leaving the cable specimen (see Annex A2, A2.1.4).

6.2.3 Place probes for sampling of combustion gas and for measurement of volume flow rate in the exhaust duct leading from the hood.

6.3 Instrumentation in the Exhaust Duct:

6.3.1 The following specifications are minimum requirements for exhaust duct instrumentation. Additional information is found in Annex A3.

6.3.2 Flow Rate Measurement—Measure the flow rate in the exhaust duct by means of a bidirectional probe, or an equivalent measuring system, with an accuracy of at least  $\pm 6\%$  (see Annex A3 for further details). The response time to a stepwise change of the duct flow rate shall not exceed 5 s to reach 90 % of the final value.

6.3.3 Use a bidirectional probe or an equivalent measuring system to measure pressure in the duct. Locate the probe shown in Fig. 2 in the exhaust duct, at least 4.6 m (15 ft) but no more than 13.7 m (45 ft) from the centerline of the collection box. Ensure that the minimum length between any

bend and the probe is at least 8 times the inside diameter of the duct. If the system is positioned at a different location, demonstrate the achievement of equivalent results.

6.3.4 Build the probe of a short stainless steel cylinder 44-mm (1.75-in.) long and 22-mm (0.875-in.) inside diameter with a solid diaphragm in the center. The pressure taps on either side of the diaphragm are also the support for the probe. Position the axis of the probe along the centerline of the duct. Connect the taps to a pressure transducer able to resolve pressure differences of 0.25 Pa (0.001 in. of water).

6.3.5 Measure gas temperatures in the vicinity of the probe with Inconel sheathed Chromel-Alumel thermocouples. Ensure that the thermocouple does not disturb the flow pattern around the bidirectional probe. Further details are discussed in Annex A3.1.

6.4 Smoke Obscuration Measurements:

6.4.1 Install an optical system for measurement of light obscuration across the centerline of the exhaust duct. Determine the optical density of the smoke by measuring the light transmitted with a photometer system consisting of a white light source and a photocell/detector or a laser system for measurement of light obscuration across the centerline of the exhaust duct. Locate the system so that it is preceded by at least eight diameters of duct without bends, to ensure a nearly uniform velocity across the duct section. If the system is positioned at a different location, demonstrate the achievement of equivalent results.

6.4.2 One photometer system found suitable consists of a lamp, lenses, an aperture and a photocell (see Fig. 3 and Annex A3.2). Construct the system so that soot deposits on the optics during a test do not reduce the light transmission by more than 5 %.

6.4.2.1 Alternatively, instrumentation constructed using a 0.5 to 2.0 mW helium-neon laser, instead of a white light system is also acceptable. See Fig. 4 and Annex A3.2 for further details. White light and laser systems give similar results (15-19).

6.5 Cable Tray:

6.5.1 Use a steel ladder cable tray,  $300 \pm 25 \text{ mm}$  ( $12 \pm 1 \text{ in.}$ ) wide,  $75 \pm 6 \text{ mm}$  ( $3 \pm 0.25 \text{ in.}$ ) deep, and  $2440 \pm 25 \text{ mm}$  ( $8 \text{ ft} \pm 1 \text{ in.}$ ) long. Arrange the tray so that the burner flame will impinge on the cables midway between rungs.

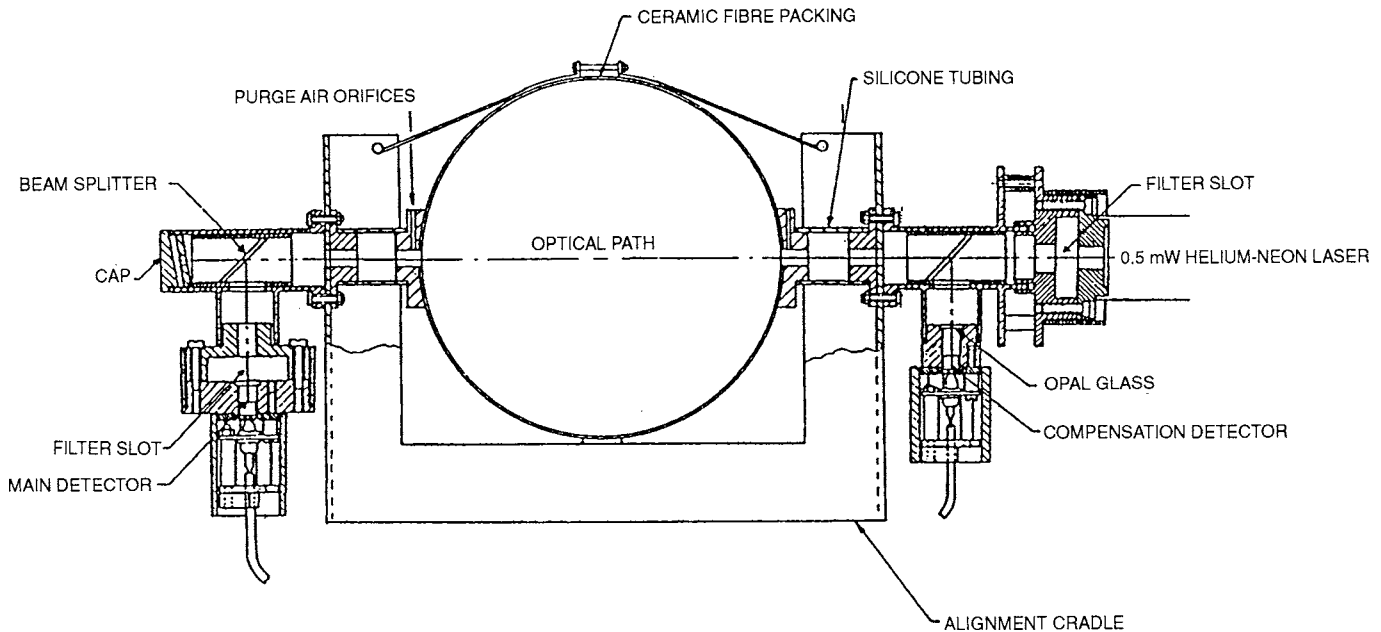

FIG. 4 Laser Extinction Beam

6.5.1.1 Each rung in the tray is to measure  $25 \pm 6$  mm ( $1 \pm 0.25$  in.) in the direction parallel to the length of the tray and  $13 \pm 3$  mm ( $0.5 \pm 0.125$  in.) in the direction parallel to the depth of the tray.

6.5.1.2 Space the rungs  $230 \pm 13$  mm ( $9 \pm 0.5$  in.) apart (measured center to center).

6.5.1.3 Attach the rungs to the side rails.

6.5.1.4 Mount the cable tray vertically in the center of the enclosure. Position the tray on a tray base (stand) which is to be no higher than  $152 \pm 25$  mm ( $6 \pm 1$  in.).

6.5.2 Place a square galvanized steel platform under the cable tray. The platform shall be constructed of nominally 1.6 mm ( $1/16$  in.) thick steel, and have dimensions of no less than 1.0 m by 1.0 m (approximately 39 in. by 39 in.), with a uniform raised lip, 100 mm (approximately 4 in.) high, on each side, to catch falling material. The platform shall be covered by a tight fitting sheet of standard gypsum board, of nominally 13 mm (0.5 in.) thickness. If a load cell is placed underneath the cable tray (as optionally in X2.1), the platform shall protect the load cell. The gypsum board shall be clean before the start of a test; if the sheet used has been damaged it shall be replaced.

NOTE 2—A square galvanized steel platform of dimensions of up to 1.22 m by 1.22 m (approximately 4 ft by 4 ft) with a raised lip is also acceptable.

#### 6.6 Burner:

6.6.1 Use a 254-mm (10-in.) strip or ribbon type propane gas burner with an air/gas Venturi mixer.

6.6.2 The flame producing surface of the burner consists essentially of a flat metal plate that is 341 mm ( $13\frac{7}{16}$  in.) long and 30 mm ( $1\frac{5}{32}$  in.) wide. The plate has an array of 242 holes drilled in it. The holes are to be 1.35 mm (metric drill size: 1.35 mm) or 0.052 in. (No. 55 drill) in diameter, on 3.2-mm (0.125-in.) centers in three staggered rows of 81, 80 and 81

holes each, to form an array measuring 257 mm ( $10\frac{1}{8}$  in.) by 5 mm ( $\frac{3}{16}$  in.). Center the array of holes on the plate (see Fig. 5).<sup>11</sup>

#### 6.6.3 Protocol A:

6.6.3.1 Position the burner behind the cable tray containing the specimen, with the flame-producing surface (face) of the burner vertical and its long dimension horizontal, and with the 257-mm ( $10\frac{1}{8}$ -in.) dimension of the array of holes spaced  $76 \pm 5$  mm ( $3.0 \pm 0.2$  in.) from the specimens in the tray and centered midway between the side rails of the tray. Position the centerpoint of the array of holes at 457 mm (18 in.) above the bottom end of the tray and specimen and midway between two rungs. Support the burner in a manner to enable the burner to be quickly removed and precisely returned to the position described. The burner faces the doorway.

#### 6.6.4 Protocol B:

6.6.4.1 Mount the burner on a stand and place it  $20 \pm 2^\circ$  from the horizontal with the burner ports up, in front of the cable tray. Locate the major axis of the burner ports  $305 \pm 25$  mm ( $12 \pm 1$  in.) above the base of the cable tray and parallel to the cable tray rungs during the fire test (Fig. 6). The burner faces the doorway.

6.6.4.2 Attach a guide to the burner or stand such that the leading edge of the burner face is located quickly and accurately  $76 \pm 5$  mm ( $3 \pm 0.2$  in.) horizontally away from the nearest surface of the cables during the burn period of the test.

6.6.5 Insert a flowmeter in both the propane and the air lines feeding the burner to measure the flow rates of these gases during the test.

6.6.6 Use a propane flowmeter capable of measuring at least  $230 \text{ cm}^3/\text{s}$  ( $29 \text{ ft}^3/\text{h}$ ) and an air flowmeter of at least  $1330 \text{ cm}^3/\text{s}$

<sup>11</sup> A satisfactory system is a burner supplied by American Gas Furnace Company, Inc., of Elizabeth, NJ. Catalog No. 10 L11-55, with an air/gas Venturi mixer, Catalog No. 14-18. Equivalent systems are probably available.

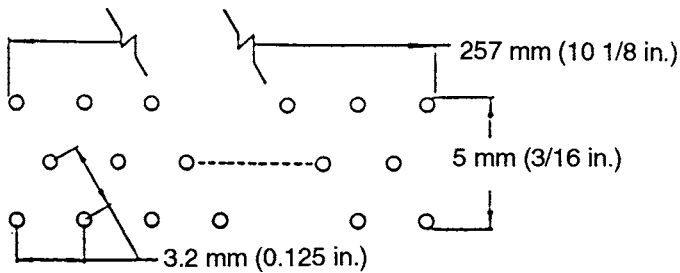

FIG. 5 Burner Holes

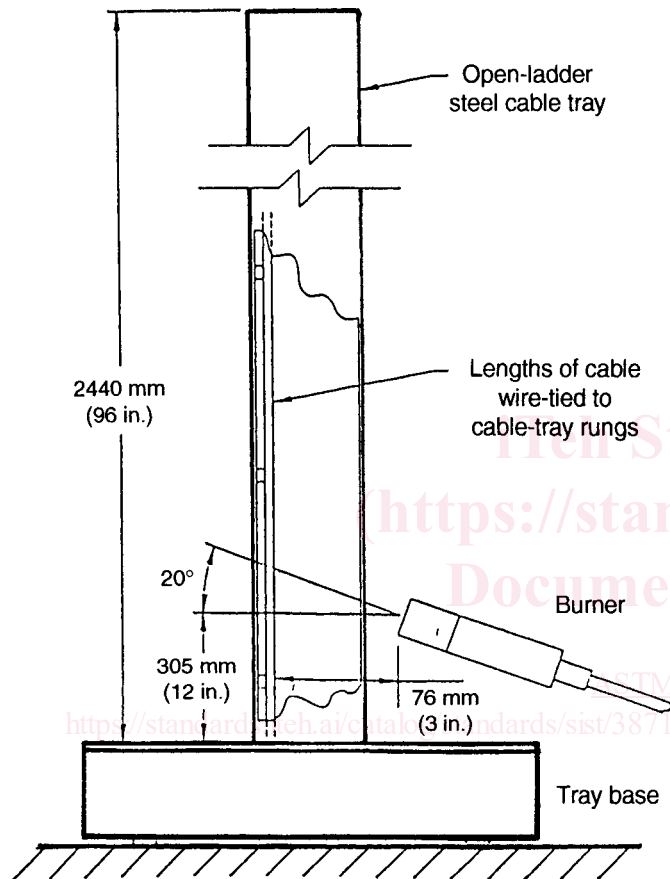

FIG. 6 Protocol B Cable Tray

TABLE 1 Tray Loading for Circular Cables Smaller than 13 mm (0.5 in.) in Diameter

Cable Diameter, mm		Number of Cables in Each Bundle	Number of Bundles in Tray
From	But Less Than		
11	13	3	7
9	11	3	8
6	9	3	10
5	6	7	9
3	5	19	8
0	3	19	13

6.6.10 Use a propane flow rate of  $220 \pm 8 \text{ cm}^3/\text{s}$  ( $28 \pm 1 \text{ ft}^3/\text{h}$ ) when corrected to standard temperature and pressure ( $20^\circ\text{C}$ ,  $101 \text{ kPa}$ ). This propane flow will provide a theoretical heat output of  $20 \text{ kW}$  (approximately  $70\,000 \text{ Btu/h}$ ). The actual heat output is less, due to incomplete combustion of the propane at the burner.

6.6.11 Use an air flow rate to the burner of  $1280 \pm 80 \text{ cm}^3/\text{s}$  ( $163 \pm 10 \text{ ft}^3/\text{h}$ ) when corrected to standard temperature and pressure.

6.7 Cable Mounting:

6.7.1 Protocol A—Fasten  $2438 \pm 10\text{-mm}$  ( $96 \pm 0.5\text{-in.}$ ) specimen lengths of finished cable in a single layer in the tray by means of steel or copper wire, not larger than  $2.1 \text{ mm}^2$  (14 AWG gage) in cross section, at their upper and lower ends and at two other equally spaced points along their lengths with each cable vertical. Install as many specimens in the tray as will fit, spaced one half cable diameter apart, to fill the center  $150 \text{ mm}$  (6 in.) of the tray width.

6.7.1.1 Determine the number of specimen lengths for test using Eq 1:

$$N = [(4 \times 25.4)/D] + 0.33 \quad (1)$$

where:

$N$  = number of cables (rounded up to the nearest whole number), and  
 $D$  = diameter of the cable, mm.

6.7.2 Protocol B—Fasten  $2438 \pm 10 \text{ mm}$  ( $96 \pm 0.5 \text{ in.}$ ) specimen lengths of finished cable in the tray. Depending upon the outside diameter of the individual cables, the test specimen is to be either an individual length or a bundle of individual lengths. Center the specimens or specimen bundles in a single layer between the side rails of the cable tray. Ensure that the lower end of each specimen is no more than  $100 \text{ mm}$  (4 in.) above the bottom end of the cable tray. Attach each individual specimen or bundle of specimens separately to each rung of the cable tray using one wrap of a copper or steel wire tie not larger than  $2.1 \text{ mm}^2$  (14 AWG) in diameter.

6.7.2.1 For cables smaller in diameter than  $13 \text{ mm}$  ( $0.5 \text{ in.}$ ), group the specimens into untwisted bundles (nominally circular) as shown in Table 1. Space the bundles one-half bundle diameter apart on the cable tray as measured at the point of attachment to the cable tray.

6.7.2.2 For cables  $13 \text{ mm}$  ( $0.5 \text{ in.}$ ) in diameter and larger, attach the individual specimens to the cable tray with spacings of  $1/2$  cable diameter, except do not exceed a spacing of  $15 \text{ mm}$  ( $0.6 \text{ in.}$ ). Table 2 shows the tray loading.

6.7.3 On flat cables, calculate the equivalent cable diameter using Eq 2:

( $170 \text{ ft}^3/\text{h}$ ). Flow rate measurements shall be accurate to within 3 %. Mass flow controllers with recordable outputs are permitted alternatives.

6.6.7 Supply compressed air to the burner, either bottled or from a compressed air system. Filter the air supply sufficiently so as to eliminate any contaminants that might affect the test results.

6.6.8 Use air with a dew point no greater than  $0^\circ\text{C}$  ( $32^\circ\text{F}$ ), as measured by a dew point measuring device.<sup>12</sup>

6.6.9 Use CP grade propane (99 % pure), having a heat content of approximately  $50.8 \text{ MJ/kg}$  ( $21.7 \text{ k Btu/lb}$ ) ( $93.0 \text{ MJ/m}^3$  at  $20^\circ\text{C}$ ,  $101 \text{ kPa}$ ), for the burner.

<sup>12</sup> A satisfactory system is Alnor Model 7000U, No. 1999, but equivalent alternative systems are probably available.

**TABLE 2 Tray Loading for Cables 13 mm (0.5 in.) in Diameter and Larger**

Cable Diameter, mm		Number of Cables in Tray
From	But Less Than	
13	15	11
15	19	9
19	21	8
21	26	7
26	28	6
28	39	5
39	52	4
52	73	3
73	120	2

$$D = 1.128 \times \sqrt{(T \times W)} \quad (2)$$

where:

$D$  = calculated equivalent cable diameter,

$T$  = minor axis of the cable, and

$W$  = major axis of the cable.

## 7. Test Specimens

7.1 Use multiple lengths of electrical or optical fiber cable as test specimens.

7.2 The mounting of the specimen on the cable tray is specified in 6.7.

## 8. Calibration

8.1 Prior to the start of each day of testing, verify the linearity of the photometer system by interrupting the light beam with multiple calibrated neutral density filters to cover the range of the recording instrument. Use at least two neutral density filters of significantly different values, and also one for 100 % transmission. Ensure that the transmittance values measured by the photometer, using neutral density filters, are within  $\pm 3$  % of the specified value for each filter.

8.2 At the end of each test, investigate and correct any excessive departure from the zero line.

8.3 Perform a calibration of the flow rates of propane and air from the burner before each continuous test series.

8.4 The recommended procedure for calibration of the propane gas flow rate is by measuring the heat release rate in the duct using Eq 3. Further details are given in X2.3.

$$\dot{q} = E \times 1.10 \times C \sqrt{\left[ \frac{\Delta p}{T_e} \right]} \times \left[ \frac{(X_{O_2}^A - X_{O_2}^A)}{1.084 - 1.5 \times X_{O_2}^A} \right] \quad (3)$$

where:

$q$  = rate of heat release, kW,

$C$  = orifice plate coefficient, in  $\text{kg}^{1/2} \text{m}^{1/2} \text{K}^{1/2}$ ,

$\Delta p$  = pressure drop across the orifice plate or bidirectional probe,

$T_e$  = gas temperature at the orifice plate, K,

$E$  = net heat released for complete combustion, per unit of oxygen consumed, 13 100 kJ/kg  $\text{O}_2$ ,

$X_{O_2}^A$  = measured mole fraction of  $\text{O}_2$  in incoming air, nondimensional, and

$X_{O_2}^A$  = measured mole fraction of  $\text{O}_2$  in exhaust flow, nondimensional.

## 9. Conditioning

9.1 Prior to testing, condition the specimen for at least 3 h in an atmosphere at a temperature of  $23 \pm 5^\circ\text{C}$  ( $73^\circ\text{F}$ ) with a relative humidity of less than 55 %. Test cables within 10 min of removal from such conditions if test room conditions differ from the preceding conditions.

## 10. Procedure

10.1 Do not carry out the test if the wall temperature of the chamber is below  $5^\circ\text{C}$  ( $41^\circ\text{F}$ ) or above  $30^\circ\text{C}$  ( $86^\circ\text{F}$ ).

10.2 Establish an initial volumetric flow rate of  $0.65 \pm 0.05 \text{ m}^3/\text{s}$  ( $23 \pm 2 \text{ ft}^3/\text{s}$ ) through the duct. Calculate the volumetric flow rate of the gas in the duct from Eq A1.1 in Annex A1 and reported as a function of time, starting 1 min prior to the test. Do not change the flow rate once the initial flow rate is established.

10.3 Position the prepared cable tray vertically inside the enclosure with the open front of the cable tray facing the front of the enclosure. Fix the cable tray firmly in position.

10.4 Start all recording and measuring devices before starting the ignition burner, to ensure they are stabilized.

10.5 Ignite the gas mixture in the burner and adjust the gas flows to the values specified in 6.6.10 and 6.6.11. Position the burner as indicated in 6.6.3 (Protocol A) or 6.6.4 (Protocol B). See Fig. 6 for the relative positions of the cable tray and burner in the enclosure.

10.6 Allow the burner flame to impinge on the specimen for a continuous period of 20 min.

10.7 At 20 min, extinguish the burner flame, but allow the cable fire (if any) to burn out.

10.8 Photograph or video record the cable tray and flame before and during the test. Include a clock, giving the time to the nearest 1 s, in all photographic records.

10.9 During the test, record the following events and the time when they occur:

10.9.1 Ignition of the specimen,

10.9.2 Position of flame front,

10.9.3 Melting and dripping,

10.9.4 Occurrence of pool fire under the specimen,

10.9.5 General description of the burning behavior,

10.9.6 Time of afterburn, after extinguishing the propane, and

10.9.7 Any other event of special interest.

NOTE 3—It is possible for ignition of the cables to occur almost immediately after ignition of the burner. However, time to ignition of the cables may be difficult to determine.

10.10 Conduct the procedure in duplicate on the number of sets of specimens specified. Conduct each procedure (burn) on untested cable specimens.

10.11 *Evaluation of Damage:*

10.11.1 After burning has ceased, and after the cables and tray have cooled to room temperature, wipe the cables clean with a cloth, and determine cable damage.

10.11.1.1 *Protocol A*—Determine the maximum height of charred cable damage by measuring the blistering, char and other damage upward from the bottom of the vertical tray.

10.11.1.2 *Protocol B*—Determine the maximum height of charred cable damage by measuring the blistering, char and other damage upward from the lower edge of the burner face.

10.11.2 Determine the limit of charring by pressing against the cable surface with a sharp object. Where the surface of the cable (outer jacket, if any) changes from a resilient surface to a brittle (crumbling) surface determines the limit of charring. Include distortion of the outer surface of the cable, such as blistering or melting, immediately above the char, in the damage measurement.

10.11.3 Record the cable damage (char) to the nearest 25 mm (1 in.). On cable constructions that do not have charring, define the limit for the affected portion as the point where the overall diameter is visibly reduced or increased.

10.11.4 For engineering information, record damage such as blistering, or softening/melting of combustible material above the char.

10.12 *Smoke Obscuration Measurements:*

10.12.1 Make continuous measurements of light obscuration by the smoke and volume flow rate in the exhaust duct.

10.12.2 From these measurements and the equations in Annex A4 determine the rates and amounts of light obscuring smoke. These values together with the visual recordings constitute the results from the test.

## 11. Calculation

11.1 Equations for smoke release calculations are presented in Annex A4. Considerations for heat release measurements (optional) are presented in Appendix X4 and the appropriate equations for calculations are in Appendix X5. The choice of the equations in Appendix X5 that the testing laboratory wishes to use for the (optional) heat release calculations is up to the testing laboratory.

## 12. Report

12.1 Report the following information:

12.1.1 *Descriptive Information:*

12.1.1.1 Name and address of the testing laboratory,

12.1.1.2 Inside dimensions of the enclosure,

12.1.1.3 Date and identification number of the report,

12.1.1.4 Name and address of the test requester,

12.1.1.5 Methods of sampling,

12.1.1.6 Name of product manufacturer or supplier, if known,

12.1.1.7 Name or other identification marks and description of the product,

12.1.1.8 Density, or weight per unit surface, and total mass, thickness of the main components in the product, and mass of combustible portion of product, if known,

12.1.1.9 Description of the samples,

12.1.1.10 Conditioning of the specimens,

12.1.1.11 Date of test, and

12.1.1.12 Test number, Protocol (A or B) and any special remarks.

12.1.2 *Test Results* (see also Appendixes).

12.1.3 *Table of Mandatory Numerical Results Containing:*

12.1.3.1 Maximum char damage, m,

12.1.3.2 Peak rate of smoke release,  $m^2s^{-1}$ , and the appropriate time that it occurred,

12.1.3.3 Total smoke released,  $m^2$ , and

12.1.3.4 Time of afterburn, s.

12.1.4 *Additional Table of Mandatory Numerical Results Containing:*

12.1.4.1 Total smoke release data after every minute, and

12.1.4.2 Rate of smoke release data after every minute.

12.1.5 *Mandatory Graphical Results:*

12.1.5.1 Plot of rate of smoke release versus time, and

12.1.5.2 Plot of total smoke released versus time.

12.2 *Descriptive Results:*

12.2.1 Photographs or videotape, if available, of the fire development, and

12.2.2 All available information listed in 10.9.

## 13. Precision and Bias

13.1 *Precision*—The precision of this test method has not been determined. Results of a planned interlaboratory test series will be included when available.

13.2 *Bias*—The true value of fire performance of electrical or optical fiber cables can only be defined in terms of a test method. Within this limitation, this test method has no known bias and can be accepted as a reference method.

## 14. Keywords

14.1 cable; cable tray; carbon dioxide; carbon monoxide; char; electrical cable; fire; fire-test response; flame; heat release; heat release rate; ignition; optical density; optical fiber cable; oxygen consumption calorimetry; smoke obscuration; smoke release; smoke release rate; total smoke released; toxic gases



## ANNEXES

### (Mandatory Information)

#### A1. CALCULATION OF VOLUMETRIC FLOW RATE

A1.1 The volumetric flow rate in m<sup>3</sup>/s in the duct under standard conditions is calculated according to Eq A1.1, as follows:

$$V_s = C_V k_r A \sqrt{\left[ \frac{2\Delta_p T_o}{\rho_o T} \right]} = 20.1 kA \sqrt{\left[ \frac{\Delta_p}{T} \right]} \quad (\text{A1.1})$$

where:

$C_V$  = a suitable calibration factor for bidirectional probes based upon air velocities in excess of 3.0 m/s (10 ft/s) in a 0.4 m (16 in.) duct, nondimensional,

$k_r$  = ratio of the average duct gas mass flow per unit area, as determined by measuring the velocity and temperature profiles across the stack, to the duct mass gas flow rate per unit area, as determined by measuring the velocity and temperature at the centerline where the bidirectional probe is located during the test,

$A$  = cross-sectional area of the duct at the location of the probe, m<sup>2</sup>,

$\Delta_p$  = differential pressure measured with the probe, Pa,  
 $\rho_o$  = density of air, kg/m<sup>3</sup>, at the reference temperature  $T_o$ ,  
 K,

$T$  = duct gas temperature, K, and

$T_o$  = the reference temperature, K.

#### A2. DESIGN OF EXHAUST SYSTEM

##### A2.1 Hood and Exhaust Duct, Recommended Design:

A2.1.1 Collect the combustion gases from the burning specimen by means of a hood. A system is described in A2.1.2 which was tested in practice and proven to fulfill the specifications given in the test method.

A2.1.2 The hood is located above the room. The bottom dimensions of the hood are 2.44 by 2.44 m (8 by 8 ft) (see Fig. 1). The hood feeds into a cubical box/plenum having 914 ± 13 mm (36.0 ± 0.5 in.) as the dimension of each side. A maximum height of 1.8 m ± 0.05 m (5 ft 11 in. ± 2 in.), to satisfy building constraints, is acceptable. Underneath the hood, two baffle plates approximately 0.61 by 0.61 m (2 by 2 ft) are located (see Fig. 1), to increase mixing of the combustion gases. Design and manufacture the hood so that no leakage exists.

A2.1.3 If a laser beam is used, a suitable means of mounting the beam together with the gas sampling probes is shown in Fig. A2.1.

A2.1.4 An exhaust duct is connected with the plenum chamber. The inner diameter of the exhaust duct is 406 ± 25 mm (16 ± 1 in.). To facilitate flow measurements, guide vanes, if needed, are located at both ends of the exhaust duct.

Alternatively, the rectilinear part of the exhaust duct must have such a length that a fully-developed flow profile is established at the point of measurement. The exhaust duct is connected to an evacuation system.

A2.1.5 Design the capacity of the evacuation system so as to exhaust minimally all combustion gases leaving the specimen. This requires an exhaust capacity of at least 2.7 kg s<sup>-1</sup> (about 8000 m<sup>3</sup> h<sup>-1</sup> at standard atmospheric conditions) corresponding to a driving under pressure of about 2 kPa at the end of the duct. Provide a means to control the exhaust flow from about 0.5 kg s<sup>-1</sup> up to maximum flow as stated above during the test process. Ensure that the measurement system has sufficient sensitivity for measurement of low rates of heat release. Mixing vanes in the duct are a means of solving the problem if concentration gradients are found to exist.

A2.1.6 An alternative exhaust system design is acceptable if it is shown to produce equivalent results. Equivalency is demonstrated by meeting the calibration requirements of Section 8. Exhaust system designs based on natural convection are unacceptable.

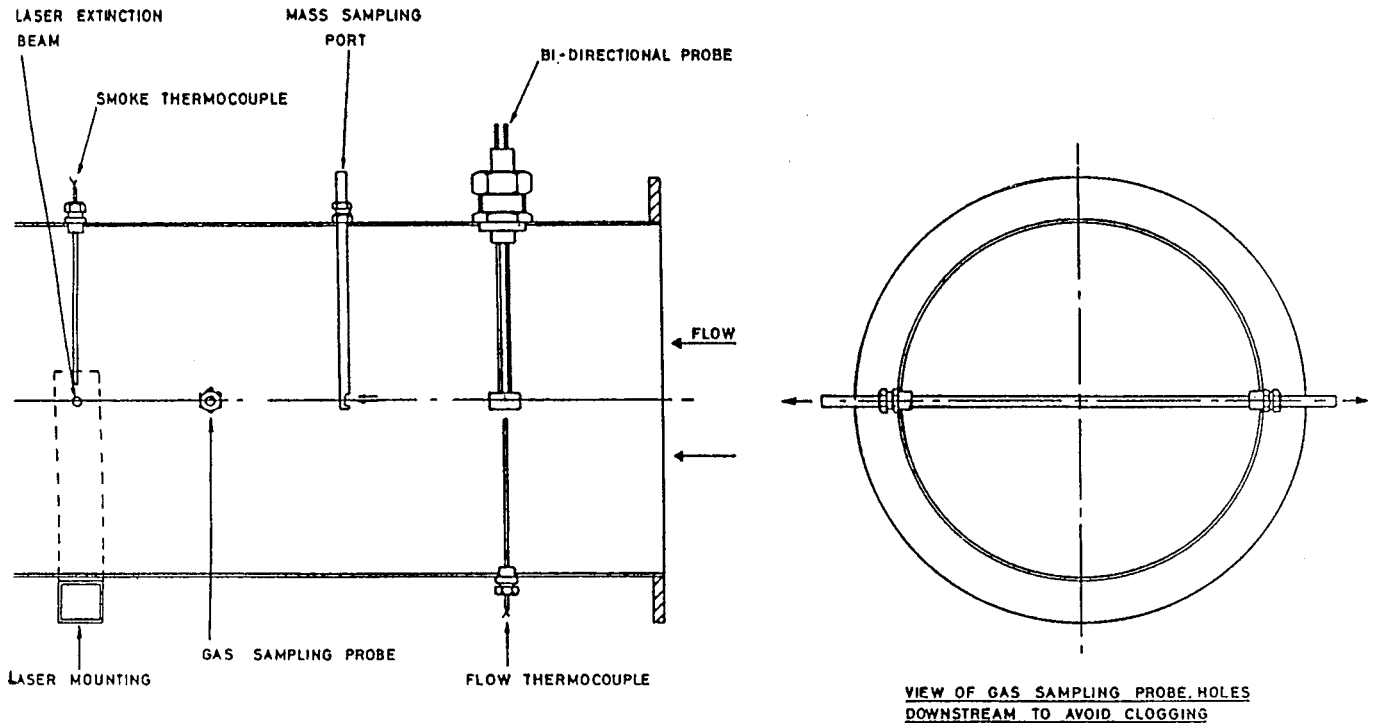

FIG. A2.1 Means of Mounting Laser Beam and Sampling Probe

### A3. INSTRUMENTATION IN EXHAUST DUCT

#### A3.1 Volume Flow:

A3.1.1 One technique for measuring the flow is a bidirectional probe located at the centerline of the duct. The probe shown in Fig. 2 consists of a stainless steel cylinder, 44 mm (1.75 in.) long and with an inner diameter of 22 mm (0.875 in.). The cylinder has a solid diaphragm in the center, dividing it into two chambers. The pressure difference between the two chambers is measured by a differential pressure transducer.

A3.1.2 Use a differential pressure transducer with an accuracy of at least  $\pm 0.25$  Pa (0.001 in.) of water and of the capacitance type. A suitable range of measurement is 0 to 150 Pa.

A3.1.3 Place one thermocouple  $152 \pm 25$  mm ( $6 \pm 1$  in.) upstream from the bidirectional probe. Use an Inconel sheathed 24 AWG gage (0.51 mm (0.020 in.) in diameter) thermocouple, type K Chromel-Alumel. Place the thermocouple wire, within 13 mm (0.5 in.) of the bead, along expected isotherms to minimize conduction errors. Use an insulation between the Chromel and Alumel wires that is stable to at least 1100°C (2000°F). Ensure that the thermocouple does not disturb the flow pattern around the bidirectional probe.

#### A3.2 Smoke Obscuration:

A3.2.1 One suitable light measuring system based on white light has the following components: a lamp, plano convex lenses, an aperture, a photocell and an appropriate power supply. Mount lenses, lamp and photocell inside two housings located on the exhaust duct, diametrically opposite each other. It has been found that a system consisting solely of a white

light and a photocell, along the exhaust duct, across from each other and at an angle to the vertical, is satisfactory in some cases.

A3.2.1.1 Use a lamp of the incandescent filament type, which operates at a color temperature of  $2900 \pm 100^\circ\text{K}$ . Supply the lamp with stabilized direct current, stable within  $\pm 0.2\%$  (including temperature, short term and long term stability). Center the resultant light beam on the photocell.

A3.2.1.2 Select the lens system such that the lens  $L_2$ , according to Fig. 3, has a diameter,  $d$ , chosen with regard to the focal length,  $f$ , of  $L_2$  so that  $d/f \leq 0.04$ .

A3.2.1.3 Place the aperture in the focus of lens  $L_2$  according to Fig. 3.

A3.2.1.4 Use a detector with a spectrally distributed response according to the CIE photopic curve and linear within 5% over an output range of at least 3.5 decades. Check this linearity over the entire range of the instrument periodically with calibrated optical filters.

A3.2.2 The system described as follows is an example of a light measuring system that has been found satisfactory:

- (1) Lenses—Plano convex: diameter 40 mm, focal length 50 mm,
- (2) Lamp—Osram Halo Stars: 64410: 6 V, 10 W, or equivalent,
- (3) Photocell—United Detector Technology: PIN 10 AP, or equivalent, and
- (4) Voltage Supply—Gresham Lion Ltd: Model G × 012, or equivalent.