



Designation: F 1264 – 03 (Reapproved 2007)<sup>e1</sup>

## Standard Specification and Test Methods for Intramedullary Fixation Devices<sup>1</sup>

This standard is issued under the fixed designation F 1264; the number immediately following the designation indicates the year of original adoption or, in the case of revision, the year of last revision. A number in parentheses indicates the year of last reapproval. A superscript epsilon ( $\epsilon$ ) indicates an editorial change since the last revision or reapproval.

<sup>e1</sup> NOTE—Editorial changes were made throughout in December 2008.

### 1. Scope

1.1 This specification is intended to provide a characterization of the design and mechanical function of intramedullary fixation devices (IMFDs), specify labeling and material requirements, provide test methods for characterization of IMFD mechanical properties, and identify needs for further development of test methods and performance criteria. The ultimate goal is to develop a standard which defines performance criteria and methods for measurement of performance-related mechanical characteristics of IMFDs and their fixation to bone. It is not the intention of this specification to define levels of performance or case-specific clinical performance of these devices, as insufficient knowledge to predict the consequences of the use of any of these devices in individual patients for specific activities of daily living is available. It is not the intention of this specification to describe or specify specific designs for IMFDs.

1.2 This specification describes IMFDs for surgical fixation of the skeletal system. It provides basic IMFD geometrical definitions, dimensions, classification, and terminology; labeling and material specifications; performance definitions; test methods and characteristics determined to be important to *in-vivo* performance of the device.

1.3 This specification includes four standard test methods:

1.3.1 Static Four-Point Bend Test Method—**Annex A1** and

1.3.2 Static Torsion Test Method—**Annex A2**.

1.3.3 Bending Fatigue Test Method—**Annex A3**.

1.3.4 Test Method for Bending Fatigue of IMFD Locking Screws—**Annex A4**.

1.4 A rationale is given in **Appendix X1**.

1.5 The values stated in SI units are to be regarded as standard. The values given in parentheses are mathematical conversions to inch-pound units that are provided for information only and are not considered standard.

<sup>1</sup> This specification is under the jurisdiction of ASTM Committee F04 on Medical and Surgical Materials and Devices and is the direct responsibility of Subcommittee F04.21 on Osteosynthesis.

Current edition approved Oct. 1, 2007. Published October 2007. Originally approved in 1989. Last previous edition approved in 2003 as F 1264 – 03.

### 2. Referenced Documents

2.1 *ASTM Standards*:<sup>2</sup>

**A 214/A 214M** Specification for Electric-Resistance-Welded Carbon Steel Heat-Exchanger and Condenser Tubes

**A 450/A 450M** Specification for General Requirements for Carbon and Low Alloy Steel Tubes

**D 790** Test Methods for Flexural Properties of Unreinforced and Reinforced Plastics and Electrical Insulating Materials

**E 4** Practices for Force Verification of Testing Machines

**E 691** Practice for Conducting an Interlaboratory Study to Determine the Precision of a Test Method

**F 86** Practice for Surface Preparation and Marking of Metallic Surgical Implants

**F 138** Specification for Wrought 18Chromium-14Nickel-2.5Molybdenum Stainless Steel Bar and Wire for Surgical Implants (UNS S31673)

**F 339** Specification for Cloverleaf Intramedullary Pins<sup>3</sup>

**F 383** Practice for Static Bend and Torsion Testing of Intramedullary Rods<sup>3</sup>

**F 565** Practice for Care and Handling of Orthopedic Implants and Instruments

**F 1611** Specification for Intramedullary Reamers

2.2 *AMS Standard*:

**AMS 5050** Steel Tubing, Seamless, 0.15 Carbon, Maximum Annealed<sup>4</sup>

2.3 *SAE Standard*:

**SAE J524** Seamless Low-Carbon Steel Tubing Annealed for Bending and Flaring<sup>4</sup>

### 3. Terminology

3.1 *Definitions for Geometric*:

<sup>2</sup> For referenced ASTM standards, visit the ASTM website, [www.astm.org](http://www.astm.org), or contact ASTM Customer Service at [service@astm.org](mailto:service@astm.org). For *Annual Book of ASTM Standards* volume information, refer to the standard's Document Summary page on the ASTM website.

<sup>3</sup> Withdrawn.

<sup>4</sup> Available from Society of Automotive Engineers (SAE), 400 Commonwealth Dr., Warrendale, PA 15096-0001, <http://www.sae.org>.

3.1.1 *closed section, n*—any cross section perpendicular to the longitudinal axis of a solid IMFD or hollow IMFD in which there is no discontinuity of the outer wall.

3.1.1.1 *Discussion*—To orient the IMFD for testing and for insertion, the desired relationship of any irregularities, asymmetries, and so forth, to the sagittal and coronal planes should be described for the intended applications.

3.1.2 *IMFD curvature, n*—dimensions of size and locations of arcs of the curvature, or mathematical description of the curvature, or other quantitative descriptions to which the curvature is manufactured along with tolerances.

3.1.2.1 *Discussion*—To orient the IMFD for testing and for insertion, the desired relationship of the curvature to the sagittal and coronal planes should be described for the intended applications.

3.1.3 *IMFD diameter, n*—diameter of the circumscribed circle that envelops the IMFDs' cross section when measured along the IMFDs' working length. If the diameter is not constant along the working length, then the site of measurement should be indicated.

3.1.4 *IMFD length, n*—length of a straight line between the most proximal and distal ends of the IMFD.

3.1.5 *open section, n*—any cross section perpendicular to the longitudinal axis of a hollow IMFD in which there is a discontinuity of the outer wall.

3.1.5.1 *Discussion*—To orient the IMFD for testing and insertion, the desired relationship of the discontinuity to the sagittal and coronal planes should be described for the intended applications.

3.1.6 *potential critical stress concentrator (CSC), n*—any change in section modulus, material property, discontinuity, or other feature of a design expected to cause a concentration of stress in a region of the IMFD expected to be highly stressed under the normal anticipated loading conditions.

3.1.7 *working length, n*—length of uniform cross section of the IMFD intended to obtain some type of fit to the medullary canal in the area of the diaphysis.

3.1.8 *tolerance, n*—acceptable deviations from the nominal size of any dimension describing the IMFD.

## 3.2 Definitions—Mechanical/Structural:

3.2.1 *bending compliance, n*—reciprocal of the stiffness of the IMFD under a bending load in a specified plane as defined and determined in the static four-point bend test described in [Annex A1](#).

3.2.2 *fatigue strength at N cycles, n*—the maximum cyclic force parameter (for example, load, moment, torque, stress, and so forth) for a given load ratio, which produces device structural damage or meets some other failure criterion in no less than *N* cycles as defined and measured according to the test conducted.

3.2.3 *failure strength, n*—the force parameter (for example, load, moment, torque, stress, and so forth) required to meet the failure criteria, as defined and measured according to the test conducted. (See [Note 1](#).)

NOTE 1—No present testing standard exists related to this term for IMFDs.

3.2.4 *yield strength, n*—the force parameter (for example, load, moment, torque, stress, and so forth) which initiates permanent deformation as defined and measured according to the test conducted.

3.2.5 *no load motion*—relative motion between the IMFD and the bone that occurs with no elastic strain in the device and no (or minimal) change in load. (See [Note 1](#).)

3.2.6 *structural stiffness, n*—the maximum slope of the elastic portion of the load-displacement curve as defined and measured according to the test conducted.

3.2.6.1 *Discussion*—For bending in a specified plane, this term is defined and determined in the static four-point bend test described in [Annex A1](#).

3.2.7 *ultimate strength, n*—maximum force parameter (for example, load, moment, torque, stress, and so forth) which the structure can support, defined and measured according to the test conducted.

3.2.8 *N*—a variable representing a specified number of cycles.

## 4. Classification

4.1 The following IMFDs may be used singly, multiply, and with or without attached supplemental fixation.

4.2 Types of IMFDs: solid cross section, hollow cross section (open, closed, combination).

4.3 Intended application or use for particular IMFD designs:

4.3.1 *Preferred Orientation:*

4.3.1.1 Right versus left,

4.3.1.2 Sagittal versus coronal plane,

4.3.1.3 Proximal versus distal, and

4.3.1.4 Universal or multiple options.

4.3.2 *Preferred Anatomic Location:*

4.3.2.1 Specific bone,

4.3.2.2 Proximal versus distal versus midshaft, and

4.3.2.3 Universal or multiple options.

4.3.3 *Preferred Use Limited to Specific Procedures:*

4.3.3.1 Acute care of fractures,

(a) Specific types,

(b) Specific locations,

4.3.3.2 Reconstructive procedures, and

4.3.3.3 Universal or multiple options.

## 5. Material

5.1 All IMFDs are made of materials that have an ASTM standard shall meet those requirements given in the ASTM standards ([2.1](#)).

## 6. Performance Considerations and Test Methods

6.1 *Cross Section Dimensional Tolerances* affect matching the bone preparation instruments (that is, reamers) to the IMFD diameter, and fit the fixation of IMFDs in the bone.

6.1.1 Terminology related to sizing of IMFD devices and instruments is provided in Terminology [F 1611](#).

6.2 *Longitudinal Contour Tolerances* (along with bending compliance) affect the fit and fixation of IMFDs in the bone.<sup>4</sup>

6.3 *Fatigue Strength* affects the choice of implant in cases in which delayed healing is anticipated (that is, infected non-unions, allografts, segmental loss, multiple trauma, and so forth).

6.3.1 The fatigue strength or fatigue lives or both for IMFDs subjected to cycle bending forces shall be determined using the cyclic bending fatigue test method described in Annex A3.

6.3.2 The fatigue strength or fatigue lives or both for IMFD locking screws subjected to cyclic bending forces shall be determined using the cyclic bending fatigue test method for locking screws described in Annex A4.

6.4 *Bending Strength* affects the choice of implant in which load sharing is minimized or loading is severe or both (that is, with distal or proximal locking, subtrochanteric fractures, comminuted fracture, segmental loss, noncompliant patient, and so forth).

6.4.1 Yield, failure, and ultimate strength for IMFDs subjected to bending in a single plane shall be determined using the static four-point bend test method described in Annex A1.

6.5 *Bending and Torsional Stiffness* may affect the type and rate of healing (primary or secondary healing) depending upon the fracture type (transverse, oblique, and so forth).

6.5.1 Bending structural stiffness for IMFDs subjected to bending in a single plane shall be determined using the static four-point bend test method described in Annex A1.

6.5.2 Torsional stiffness for IMFDs subjected to pure torsion shall be determined using the static torsion test method described in Annex A2.

6.6 *No-Load Axial and Torsional Motion Allowed in Devices Using Secondary Attached Fixation* affects degree of motion at the fracture site. (See Note 1.)

6.7 *Extraction System*—Mechanical failures should occur in the extraction device before they occur in the IMFD. This prevents the need to remove the IMFD without proper tools. (See Note 1.)

**7. Marking, Packaging, Labeling, and Handling**

7.1 Dimensions of IMFDs should be designated by the standard definitions given in 3.1.

7.2 Mark IMFDs using a method specified in accordance with Practice F 86.

7.3 Use the markings on the IMFD to identify the manufacturer or distributor. Mark away from the most highly stressed areas where possible.

7.4 Packaging shall be adequate to protect the IMFD during shipment.

7.5 Include the following on package labeling for IMFDs:

7.5.1 Manufacturer and product name,

7.5.2 Catalog number,

7.5.3 Lot or serial number,

7.5.4 IMFD diameter (3.1.3), and

7.5.5 IMFD length (3.1.4).

7.6 Care for and handle IMFDs in accordance with Practice F 565.

**8. Means for Insertion and Extraction**

8.1 For IMFDs that are to be extracted using a hook device, the following requirements apply:

8.1.1 The slot at the end of the IMFD shall have the dimensions shown in Fig. 1.

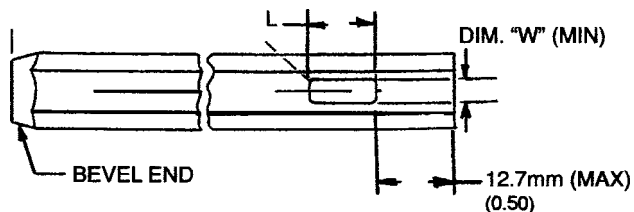

IMFD Diameter, mm	Hook Size	Slot Length, L, mm (in.)	Slot Width, W, mm (in.)
6, 7	2	9.53 (0.375)	1.91 (0.075)
8 and larger	1	9.53 (0.375)	3.23 (0.127)

FIG. 1 Dimensions of Extractor Hook Slot

8.1.2 The hook used for extraction shall have the dimensions shown in Fig. 2.

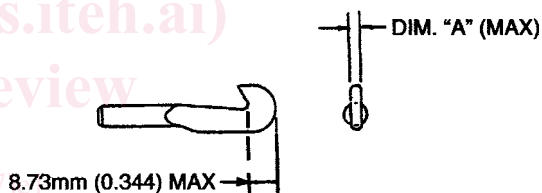

Hook Size	Hook Width, A, mm (in.)
1	3.05 (0.120)
2	1.78 (0.070)

FIG. 2 Dimensions of Extractor Hook

**9. Keywords**

9.1 bend testing; definitions; extraction; fatigue test; fracture fixation; implants; intramedullary fixation devices; orthopaedic medical device; performance; surgical devices; terminology; test methods; torsion test; trauma

## ANNEXES

### (Mandatory Information)

#### A1. TEST METHOD FOR STATIC FOUR-POINT BEND TEST METHOD

##### A1.1 Scope

A1.1.1 This test method describes methods for static four-point bend testing of intrinsic, structural properties of intramedullary fixation devices (IMFDs) for surgical fixation of the skeletal system. This test method includes bend testing in a variety of planes relative to the major anatomic planes. The purpose is to measure bending strength and bending stiffness intrinsic to the design and materials of IMFDs.

A1.1.2 This test method is designed specifically to test IMFD designs that have a well-defined working length ( $WL$ ) of uniform open or closed cross section throughout the majority of its length ( $WL \geq 10 \times$  diameter) and is to be applied to the full length of the diaphysis of a femur, tibia, humerus, radius, or ulna. This is not applicable to IMFDs that are used to fix only a short portion of the diaphysis of any of the long bones or the diaphysis of small bones such as the metacarpals, metatarsals, phalanges, and so forth.

A1.1.3 This test method is not intended to test the extrinsic properties of any IMFD, that is, the interaction of the device with bone or other biologic materials.

A1.1.4 This test method is not intended to define case-specific clinical performance of these devices, as insufficient knowledge to predict the consequences of the use of any of these devices in individual patients is available.

A1.1.5 This test method is not intended to serve as a quality assurance document, and thus, statistical sampling techniques for batches from production of IMFDs are not addressed.

A1.1.6 This test method may not be appropriate for all types of implant applications. The user is cautioned to consider the appropriateness of the method in view of the devices being tested, the material of their manufacture, and their potential applications.

A1.1.7 The values stated in SI units are to be regarded as the standard.

A1.1.8 *This standard does not purport to address all of the safety concerns, if any, associated with its use. It is the responsibility of the user of this standard to establish appropriate safety and health practices and determine the applicability of regulatory limitations prior to use.*

##### A1.2. Terminology

###### A1.2.1 Definitions:

A1.2.1.1 *bending compliance,  $n$* —reciprocal of the stiffness of the IMFD under a bending load in a specified plane ( $1/EI_e$  for the IMFD,  $y/F$  for the system tested).

A1.2.1.2 *bending moment,  $n$* —moment required to meet predetermined failure criteria measured in accordance with [A1.5.1](#).

A1.2.1.2.1 *Discussion*—Failure may be defined by permanent deformation, breakages, or buckling.

A1.2.1.3 *bending moment to yield,  $n$* —moment which produces plastic deformation as defined by the 0.2 % strain off-set method from the load-displacement curve.

A1.2.1.4 *bending structural stiffness,  $n$* —resistance to bending of an IMFD tested in accordance with the procedures of [A1.5.1](#), normalized to the cross-sectional properties of the working length without regard to the length of IMFD tested, by the calculations described in [A1.5.1.8](#) (the effective  $EI_e$  for the region tested).

A1.2.1.5 *fixture/device compliance,  $n$* —measurement of the combined compliance of the IMFD on the test fixture with co-aligned load-support points (such as [A1.6.2](#)). This value is dependent upon IMFD orientation, load direction and load and support spans.

A1.2.1.6 *ultimate bending moment,  $n$* —moment at the maximum or ultimate load as measured on the load-displacement curve for any test in accordance with [A1.5.1](#).

###### A1.2.2 Definitions of Terms Specific to This Standard:

A1.2.2.1 The testing mode shall consist of an applied compression load cycle, at a constant displacement rate, to a defined failure.

A1.2.2.2 The testing mode shall be single cycle with the load applied at least three diameters of the IMFD from the nearest critical stress concentration point (CSC) unless otherwise specified or unless the CSC is a characteristic of the normal cross section in the working length.

##### A1.3 Classification

###### A1.3.1 Types of Test Covered by This Specification Are:

A1.3.1.1 Measurement of structural mechanical behavior inherent to IMFDs—intrinsic properties.

A1.3.1.2 Measurement of single-cycle elastic stiffness and strength in four-point bending.

A1.3.1.3 Measurement of a single-cycle fixture/device elastic compliance.

##### A1.4 Procedure

###### A1.4.1 Bending Test for Intrinsic Properties of the Working Length ( $WL$ ):

A1.4.1.1 Determine the spans to be used as described in [A1.4.1.2](#) and [A1.4.1.3](#) and set the spans,  $s$ ,  $c$ , and  $L$  to within 1 % of the determined values.

A1.4.1.2 Conduct four-point bending at room atmospheric conditions as shown in [Fig. A1.1](#) using two rolling supports spaced from 10 to 50 cm apart,  $L$ , with the span between the loading points,  $c$ , no greater than  $L/3$ . Loading points should also be of the rolling type, and the diameter of both the loading

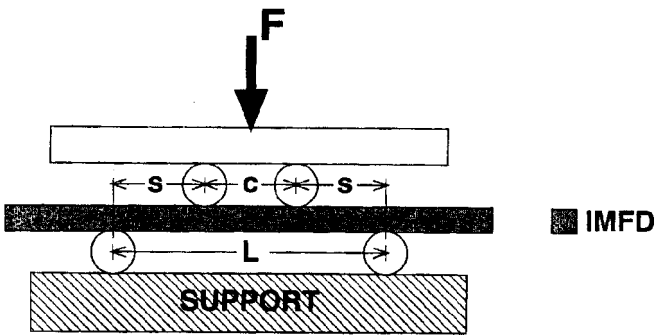

**RANGE OF SPANS, in mm**

**L = 100 -> 500**

**s = 33 -> 250**

**c = 0 -> 167**

**FIG. A1.1 Four-Point Bend Test Setup**

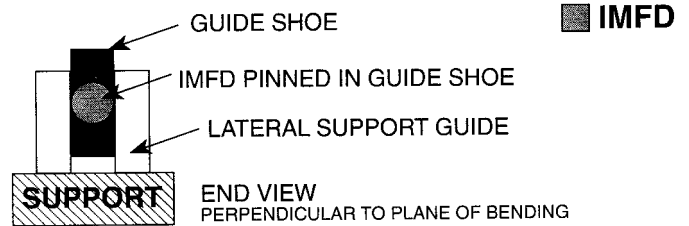
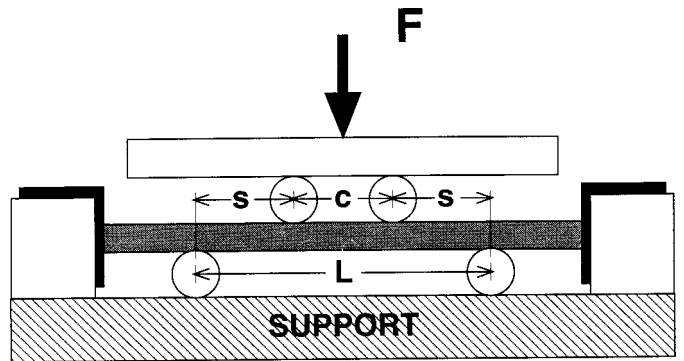

**FIG. A1.2 Four-Point Bend Test with Guide Shoes**

and support rollers should be between 1.0 and 2.6 cm. The choice of spans should be made based upon the guidelines given in A1.7.1.

A1.4.1.3 A recommendation for load and support spans is provided below to minimize interlaboratory variability and provide consistency with the previous ASTM standard for four-point bend testing of IMFDs. The suggested long or short span should be used whenever possible, provided the general guidelines of A1.7.1 are achieved. The short span is identical to that used in the previous standard, Practice F 383, and the long span is based upon the experience of several laboratories testing a broad range of design and sizes of current (1995) IMFD designs.

Short span	$s = c = 38 \text{ mm (1.5 in.)}$	$L = 114 \text{ mm (4.5 in.)}$
Long span	$s = c = 76 \text{ mm (3.0 in.)}$	$L = 228 \text{ mm (9.0 in.)}$

A1.4.1.4 Apply equal loads at each of the loading points (a single load centered over the load points as shown in Figs. A1.1 and A1.2 is the usual method) at a constant rate of displacement no greater than 1 mm/s. Measure the relative deflections between the support and loading points (inner versus outer),  $y$ . For devices made of strain-rate-sensitive materials, the displacement rate for a given strain rate may be estimated by using the following approximations:

$$y_R = S_{t1\%}, \text{ and } c = L - 2s \quad (\text{A1.1})$$

$$y_{1\%} = \frac{s(L + 2c)}{300 D_{IMFD}} \quad (\text{A1.2})$$

$$= \frac{s(3L - 4s)}{300 D_{IMFD}}$$

or

$$= \frac{s(3c + 2s)}{300 D_{IMFD}}$$

where:

- $S_t$  = the desired strain rate,
- $y_{1\%}$  = the deflection at the loading point for an estimated 1% maximum strain in the IMFD,
- $s$  = the span from a load point to the nearest support,
- $c$  = the center span,
- $L$  = the total span ( $c + 2s$ ), and
- $D_{IMFD}$  = the diameter of the IMFD.

NOTE A1.1—The estimate of the deflection rate that corresponds to the desired strain rate is only a rough estimate based upon the assumptions of plane strain for closed-section tubes or solid rods so that the neutral axis of the cross section lies uniformly throughout the working length in the center of the circumscribed circle of the cross section and that there is material in the cross section touching the circumscribed circle where it intersects the plane of bending.

A1.4.1.5 Compute the bending moment,  $M$ , as used in A1.2.1 as follows:

$$M = Fs/2 \quad (\text{A1.3})$$

where:

- $F$  = the force applied to the system (two times the force applied to each of the loading points) and
- $s$  = the span from a load point to the nearest support.

A1.4.1.6 Compute an estimate for the maximum strain in the IMFD as follows:

$$S_{MAX} = FS D_{IMFD} (4 EI_e)^{-1} \quad (\text{A1.4})$$

$$y = Fs^2 (L + 2c) (12 EI_e)^{-1} \quad (\text{A1.5})$$

where:

- $S_{MAX}$  = estimate of maximum strain in the IMFD,
- $F$  = force on the system,
- $s$  = span from a load point to the nearest support point,
- $EI_e$  = effective structural stiffness of the IMFD portion tested,
- $D_{IMFD}$  = diameter of the IMFD,
- $L$  = the total span between supports ( $2s + c$ ), and
- $c$  = the center span.

A1.4.1.7 Compute the bending moment to yield by estimating the load at 0.2% maximum plastic strain. This can be approximated by calculating as follows:

$$y_{0.2\%} = s(L + 2c)/(1500 D_{IMFD}) \quad (\text{A1.6})$$

where:

- $y_{0.2\%}$  = the permanent deflection at the loading point for 0.2 % maximum plastic strain (estimated by measuring the offset displacement from the linear region of the load-displacement curve),
- $s$  = the span from a load point to the nearest support,
- $c$  = the center span,
- $L$  = the total span ( $c + 2s$ ), and
- $D_{IMFD}$  = the diameter of the IMFD.

At this point on the load-deflection curve, read the yield force,  $F_y$ . From  $F_y$ , the bending moment to yield is computed from:

$$M_y = F_y s / 2, \text{ (see Fig.A1.3)} \quad (A1.7)$$

Likewise, the ultimate bending moment,  $M_{MAX}$ , may be determined from the load-deflection curve as follows:

$$M_{MAX} = F_{MAX} s / 2, \text{ (see Fig.A1.3)} \quad (A1.8)$$

NOTE A1.2—The estimate of the deflection that corresponds to the 0.2 % desired strain is only a rough estimate based upon the assumptions of plane strain for closed section tubes or solid rods so that the neutral axis of the cross section lies uniformly throughout the working length in the center of the circumscribed circle of the cross section and that there is material in the cross section touching the circumscribed circle where it intersects the plane of bending.

A1.4.1.8 Compute the bending structural stiffness as follows:

$$EI_e = s^2(L + 2c)(F/y) / 12 \quad (A1.9)$$

or

$$EI_e = s^2(3L - 4s)(F/y) / 12 \quad (A1.10)$$

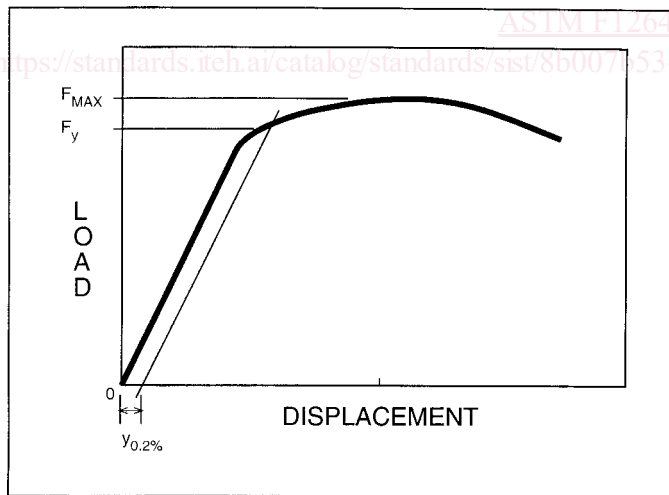

NOTE 1—An estimate of a 0.2 % yield point can be made from the “load cell versus ram displacement” measurements. Load represents the total load on the system ( $2 \times$  the load at each support) and the displacement represents the deflection at the load point(s) relative to the supports in the  $y$  (or vertical) direction. Setting  $S_{MAX} = 0.002$  in the strain estimate equation (A1.5.1.6) and substituting into  $y$  gives:

$$y_{0.2\%} = 2 s (L + 2c) (3D_{IMFD})^{-1} \times 10^{-3}$$

where:  $y_{0.2\%}$  = an estimate of the deflection at the load point which corresponds to 0.2 % strain.

FIG. A1.3 Load Cell Versus Ram Displacement Graph

where:

- $F/y$  = the slope of the elastic portion of the load-displacement curve,
- $s$  = the span from a load point to the nearest support,
- $c$  = the center span, and
- $L$  = the total span ( $c + 2s$ ).

NOTE A1.3—If no linear range can be easily approximated from the load-displacement curve, the ratio of the bending load to yield, as defined in A1.2.1.1, to the total deflection produced by that load at the loading point, when tested in accordance with the procedures of A1.5.1 can be used to estimate the average slope of the elastic range of bending.

A1.4.1.9 Bending should be applied in the planes of maximum ( $I_{max}$ ) and minimum ( $I_{min}$ ) area moments of inertia of the working length cross section, and the orientation of the principal inertia axes relative to the  $ML$  and  $AP$  anatomic planes should be reported. If the working length of the IMFD does not have a uniform cross section, or is twisted such that the orientation of the principal inertial axes are not constant along its length, then the IMFD should be loaded in the  $ML$  and  $AP$  anatomic planes, with the IMFD oriented relative to the anatomic planes as defined from its intended clinical application.

A1.4.1.10 For IMFDs that have rotational instability for any given bending mode, the ends should be gripped by the fixtures shown in Fig. A1.2. This fixture will allow the IMFD to be constrained outside the actively loaded region by plates that prevent rotation of the IMFD while allowing the in-plane bending with supported, free ends in such a manner that the ends are stable when the IMFD rests on the outer support rollers. The use of guide shoes will produce a mixed loading condition as a result of friction in the portion of the system that resists rotation, which will contribute to the bending resistance. The magnitude of this effect is not easily measured or estimated but should be noted in the report.

A1.4.2 Fixture/Device Compliance Test for the Intrinsic Properties of the Working Length:

A1.4.2.1 Align both of the supports directly in line with the load points (see Fig. A1.4).

A1.4.2.2 Place the working length of the IMFD between the load point and support. Orient the IMFD so that the load is applied in the desired plane ( $AP$ ,  $ML$ , or another specified direction).

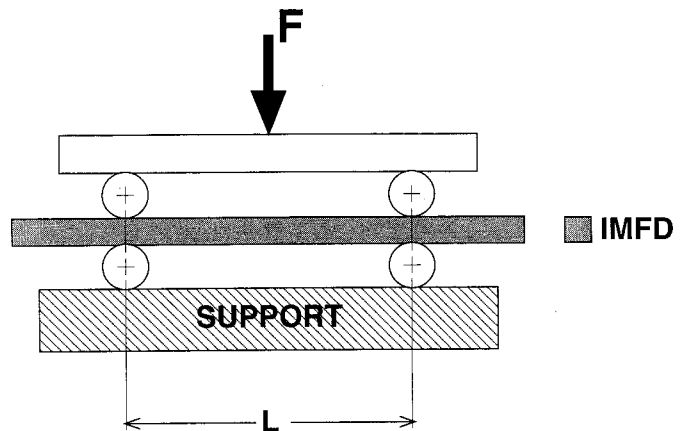

FIG. A1.4 Fixture/Device Compliance Test Setup