



Designation: ~~F382–99 (Reapproved 2003)~~<sup>ε1</sup> Designation: F 382 – 99 (Reapproved 2008)

## Standard Specification and Test Method for Metallic Bone Plates<sup>1</sup>

This standard is issued under the fixed designation F 382; the number immediately following the designation indicates the year of original adoption or, in the case of revision, the year of last revision. A number in parentheses indicates the year of last reapproval. A superscript epsilon ( $\epsilon$ ) indicates an editorial change since the last revision or reapproval.

~~<sup>ε1</sup>Note—Editorial changes were made throughout in December 2004.~~

### 1. Scope

1.1 This specification and test method is intended to provide a comprehensive reference for bone plates used in the surgical internal fixation of the skeletal system. The standard establishes consistent methods to classify, define the geometric characteristics, and performance characteristics of bone plates. The standard also presents a catalog of standard specifications that specify material; labeling and handling requirements; and standard test methods for measuring performance related mechanical characteristics determined to be important to the *in vivo* performance of bone plates.

1.2 It is not the intention of the standard to define levels of performance or case-specific clinical performance for bone plates, as insufficient knowledge is available to predict the consequences or their use in individual patients for specific activities of daily living. Furthermore, it is not the intention of the standard to describe or specify specific designs for bone plates used in the surgical internal fixation of the skeletal system.

1.3 This document may not be appropriate for all types of bone plates. The user is cautioned to consider the appropriateness of the standard in view of a particular bone plate and its potential application.

1.4 This document includes the following test methods used in determining the following bone plate mechanical performance characteristics.

1.4.1 Standard Test Method for Single Cycle Bend Testing of Metallic Bone Plates—Annex A1.

1.4.2 Standard Test Method for Determining the Bending Fatigue Properties Of Metallic Bone Plates—Annex A2.

~~1.5 Unless otherwise indicated, the values stated in SI units shall be regarded as the standard.~~

1.5 The values stated in SI units are to be regarded as standard. The values given in parentheses are mathematical conversions to inch-pound units that are provided for information only and are not considered standard.

1.6 *This standard does not purport to address all of the safety concerns, if any, associated with its use. It is the responsibility of the user of this standard to establish appropriate safety and health practices and determine the applicability of regulatory limitations prior to use.*

### 2. Referenced Documents

2.1 *ASTM Standards:*<sup>2</sup>

~~F67 Specification for Unalloyed Titanium for Surgical Implant Applications~~ F67 Specification for Unalloyed Titanium, for Surgical Implant Applications (UNS R50250, UNS R50400, UNS R50550, UNS R50700)

F 75 Specification for Cobalt-28 Chromium-6 Molybdenum Alloy Castings and Casting Alloy for Surgical Implants (UNS R30075)

F 86 Practice for Surface Preparation and Marking of Metallic Surgical Implants

F 90 Specification for Wrought Cobalt-20Chromium-15Tungsten-10Nickel Alloy for Surgical Implant Applications (UNS ~~R56401~~) R30605)

F 136 Specification for Wrought Titanium-6Aluminum-4Vanadium ELI (Extra Low Interstitial) Alloy for Surgical Implant Applications (UNS R56401)

F 138 Specification for Wrought 18Chromium-14Nickel-2.5Molybdenum Stainless Steel Bar and Wire for Surgical Implants (UNS S31673)

F 139 Specification for Wrought 18Chromium-14Nickel-2.5Molybdenum Stainless Steel Sheet and Strip for Surgical Implants (UNS S31673)

<sup>1</sup> This specification and test method is under the jurisdiction of ASTM Committee F04 on Medical and Surgical Materials and Devices and is the direct responsibility of Subcommittee F04.21 on Osteosynthesis.

Current edition approved Apr. 10, 2003; Nov. 1, 2008. Published May 2003; November 2008. Originally approved in 1973. Last previous edition approved in 1999 as F 382 – 99(2003)<sup>ε1</sup>.

<sup>2</sup> For referenced ASTM standards, visit the ASTM website, www.astm.org, or contact ASTM Customer Service at service@astm.org. For *Annual Book of ASTM Standards* volume information, refer to the standard's Document Summary page on the ASTM website.

- F 543 Specification and Test Methods for Metallic Medical Bone Screws
  - F 565 Practice for Care and Handling of Orthopedic Implants and Instruments
  - F 620 Specification for Alpha Plus Beta Titanium Alloy Forgings for Surgical Implants
  - F 621 Specification for Stainless Steel Forgings for Surgical Implants
  - F 983 Practice for Permanent Marking of Orthopaedic Implant Components
  - F 1295 Specification for Wrought Titanium-6Aluminum-7Niobium Alloy for Surgical Implant Applications (UNS R56700)
  - ~~F1314 Wrought Nitrogen Strengthened-22Chromium-12.5Nickel-5Manganese-2.5Molybdenum Stainless Steel Bar and Wire for Surgical Implants (UNS S20910)~~ 1314 Specification for Wrought Nitrogen Strengthened 22 Chromium 13 Nickel 5 Manganese 2.5 Molybdenum Stainless Steel Alloy Bar and Wire for Surgical Implants (UNS S20910)
  - ~~F1472 Specification for Alpha Plus Beta Titanium Alloy Forgings for Surgical Implants~~ 1472 Specification for Wrought Titanium-6Aluminum-4Vanadium Alloy for Surgical Implant Applications (UNS R56400)
  - F 1713 Specification for Wrought Titanium-13Niobium-13Zirconium Alloy for Surgical Implant Applications (UNS R58130)
- 2.2 ISO Standard:<sup>3</sup>  
 FDIS 14602 Non-active surgical implants—Implants for Osteosynthesis particular requirements.

**3. Terminology**

3.1 Definitions—Geometric:

3.1.1 *auto compression*—a type of bone plate that by its design can generate a compressive force between adjacent unconnected bone fragments through the use of one or more ramped holes or another type of slot geometry. This ramp or slot geometry contacts the underside of the screw head, and induces compressive force as the screw is inserted and tightened to the bone plate.

3.1.2 *bone plate*—a metallic device with two or more holes or slot(s), or both, and a cross section that consists of at least two dimensions (width and thickness) which generally are not the same in magnitude. The device is intended to provide alignment and fixation of two or more bone sections, primarily by spanning the fracture or defect. The device is typically fixed to the bone through the use of bone screws or cerclage wire. A partial list of general types of bone plates is given in Section 4.1.

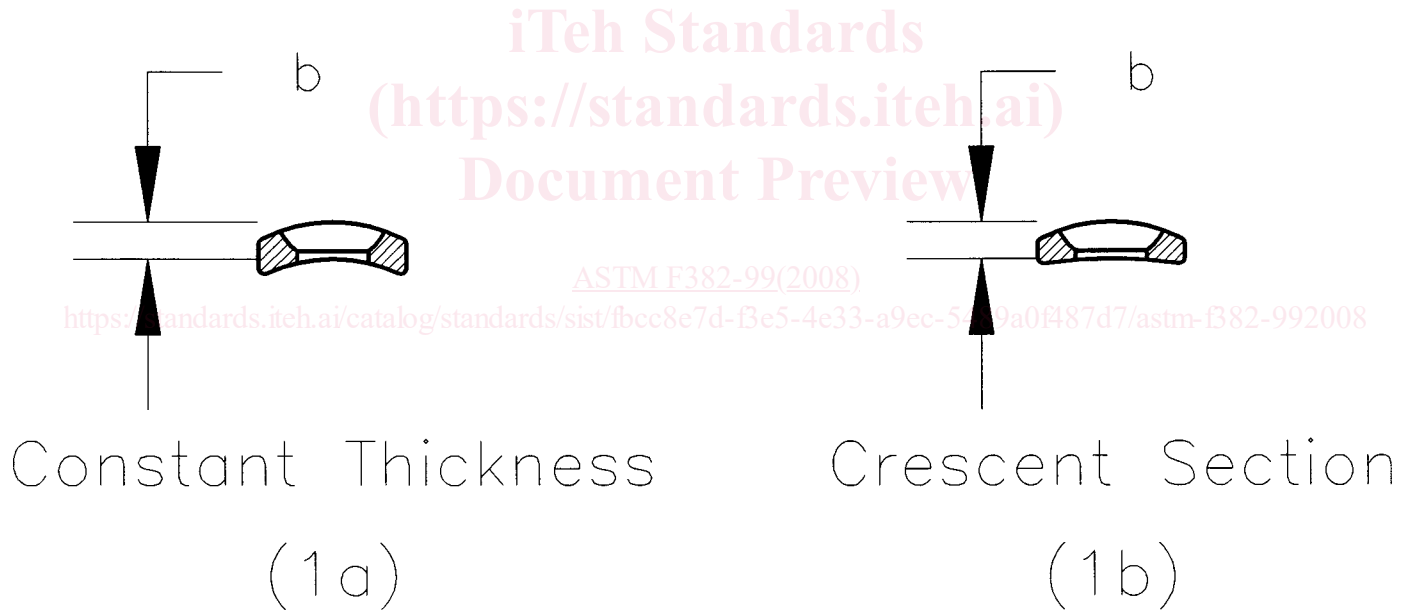

**FIG. 1 Bone Plate Cross-sections**

3.1.3 *bone plate length, L (mm)*—the linear dimension of the bone plate measured along the longitudinal axis as illustrated in Fig. 2.

3.1.4 *bone plate thickness, b (mm)*—the linear dimension of the bone plate measured parallel to the screw hole axis as shown in Fig. 1a, 1b, and Fig. 2. For a bone plate with a crescent section, the thickness is measured at the thickest point along the section.

3.1.5 *bone plate width, w (mm)*—the linear dimension of the bone plate measured perpendicular to both the length and thickness axes as shown in Fig. 2.

3.1.6 *contouring*—the manipulation and bending of a bone plate, either pre-operatively or intra-operatively, to match the anatomic geometry of the intended fixation location.

<sup>2</sup> Available from International Standards Organization, Rue de Varembe, Case Postale 56, CH-1211, Geneva 20, Switzerland.  
<sup>3</sup> Available from American National Standards Institute (ANSI), 25 W. 43rd St., 4th Floor, New York, NY 10036, <http://www.ansi.org>.

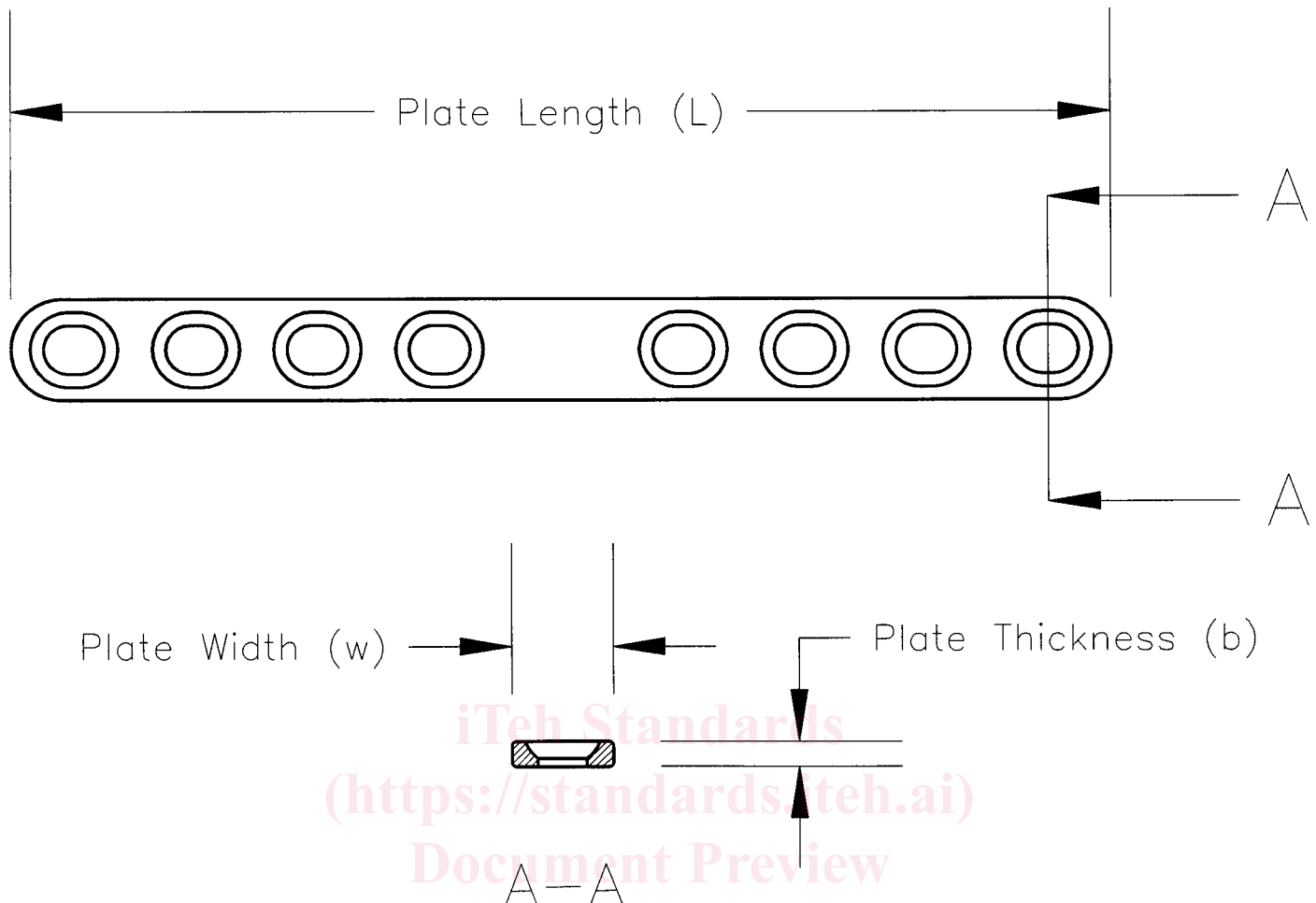

FIG. 2 Bone Plate Dimensions

3.1.7 *crescent section*—a bone plate cross-section shape (perpendicular to the long axis of the bone plate) where the thickness is not constant along the section. Typically the section is thickest along the bone plate's centerline and tapers to a smaller thickness at the bone plate's edges (see Fig. 1b).

3.1.8 *uniform width*—referring to a bone plate where the width is constant along the bone plate's length.

3.2 *Definitions—Mechanical/Structural:*

3.2.1 *bending stiffness,  $K$  (N/mm)*—of a bone plate, the maximum slope of the linear elastic portion of the load versus load-point displacement curve for a bone plate when tested according to the test method of Annex A1.

3.2.2 *bending strength (N-m)*—of a bone plate, the bending moment necessary to produce a 0.2 % offset displacement in the bone plate when tested as described in Annex A1.

3.2.3 *bending structural stiffness,  $EI$  (N-m<sup>2</sup>)*—of a bone plate, the bone plate's normalized effective bending stiffness that takes into consideration the effects of the test setup's configuration when tested according to the method described in Annex A1.

3.2.4 *fatigue life,  $n$* —The number of loading cycles of a specified character that a given specimen sustains before failure of a specified nature occurs.

3.2.5 *fatigue strength at  $N$  cycles*—An estimate of the cyclic forcing parameter (for example, load, moment, torque, stress, and so on) at a given load ratio, for which 50 % of the specimens within a given sample population would be expected to survive  $N$  loading cycles.

#### 4. Classification

4.1 Bone plates used in general orthopaedic surgery can be categorized into general types according to the following classifications.

4.1.1 *cloverleaf plate*—a bone plate that has one three-lobed end which contains screw holes.

4.1.2 *cobra head plate*—a bone plate that has one flared triangular or trapezoidal end which contains multiple screw holes or slots, or both. This type of bone plate is often used for hip arthrodesis.

4.1.3 *reconstruction plate*—a bone plate that does not have a uniform width, but usually has a smaller cross-section between the screw holes or slots. The reduced cross-section between screw holes/slots facilitates contouring the bone plate in several planes. Reconstruction plates are often used in fractures of the pelvis and acetabulum.

4.1.4 *straight plate*—a bone plate with uniform width and a straight longitudinal axis. Straight plates are often used for fractures of the diaphysis of long bones.

4.1.5 *tubular plate*—a bone plate whose cross-section resembles a portion of a tube, and which has a constant thickness or a crescent section. Tubular plates are often used for fractures of the smaller long bones (that is, radius, ulna, fibula).

## 5. Marking, Packaging, Labeling, and Handling

5.1 Dimensions of bone plates should be designated by the standard definitions given in Section 3.1.

5.2 Bone plates shall be marked using a method specified in accordance with either Practice F 983 or ISO 14602.

5.3 Markings on bone plates shall identify the manufacturer or distributor and shall be made away from the most highly stressed areas, where possible.

5.4 Packaging shall be adequate to protect the bone plates during shipment.

5.5 Package labeling for bone plates shall include when possible the following information:

5.5.1 Manufacturer and Product Name,

5.5.2 Catalog number,

5.5.3 Lot or serial number,

5.5.4 Material and, where applicable, its associated ASTM specification designation number,

5.5.5 Number of screw holes,

5.5.6 Bone plate width,

5.5.7 Bone plate length,

5.5.8 Bone plate thickness, and

5.5.9 ASTM specification designation number.

5.6 Bone plates should be cared for and handled in accordance with Practice F 565, as appropriate.

## 6. Materials

6.1 All bone plates made of materials which have an ASTM committee F04 standard designation shall meet those requirements given in the ASTM standards. A majority of materials having ASTM specifications can be found in the list of referenced ASTM standards of Section 2.1.

6.2 Bone plates of forged Specification F 136 shall meet the requirements of specification F 620.

6.3 Bone plates of forged Specification F 138 shall meet the requirements of specification F 621.

## 7. General Requirements and Performance Considerations

7.1 *geometric considerations*—bone plates that are intended to be used with bone screws shall have design features (screw holes or slots) that conform or appropriately fit the corresponding bone screw.

7.2 *bending properties*—a critical characteristic of bone plates for orthopedic applications since the bone plate provides the primary means of stabilizing the bone fragments. Additionally, the bending stiffness of the bone plate may directly affect the rate and ability of healing.

7.2.1 The relevant bending properties (bending stiffness, bending structural stiffness, and bending strength) shall be determined using the standard test method of Annex A1.

7.2.2 Determine the relevant bending fatigue properties according to the methods described in Annex A2.

## 8. Keywords

8.1 bend testing—surgical implants; fatigue test; bone plate; orthopedic medical devices—bone plates; surgical devices; test methods—surgical implants

## ANNEXES

### A1. STANDARD TEST METHOD FOR SINGLE CYCLE BEND TESTING OF METALLIC BONE PLATES<sup>1</sup>

#### A1.1 *Scope*:

A1.1.1 This test method describes methods for single cycle bend testing in order to determine intrinsic, structural properties of metallic bone plates. The test method measures the bending stiffness, bending structural stiffness, and bending strength of bone plates.

A1.1.2 This test method is intended to provide a means of mechanically characterize different bone plate designs. It is not the intention of this standard to define levels of performance for bone plates as insufficient knowledge is available to predict the consequences of the use of particular bone plate designs.

A1.1.3 *Units*—The values stated in SI units are to be regarded as standard. No other units of measurement are included in this standard.

A1.1.4 *This standard does not purport to address all of the safety concerns, if any, associated with its use. It is the responsibility of the user of this standard to establish appropriate safety and health practices and determine the applicability of regulatory limitations prior to use.*

NOTE A1.1—There is currently an ISO standard (ISO 9585—Implants for Surgery—Determination of Bending Strength and Stiffness of Bone Plates) that is similar, but not equivalent to this test method.

A1.2 Referenced Documents:

A1.2.1 *ASTM Standards*<sup>2</sup>:

E 4 Practices for Load Verification of Testing Machines

E 122 Practice for Choice of Sample Size to Estimate the Average Quality of a Lot or Process

A1.3 Terminology:

A1.3.1 Definitions:

A1.3.1.1 *0.2 % offset displacement, q (mm)*—permanent deformation equal to 0.2 % of the center loading span distance. (point B in Fig. A1.1).

A1.3.1.2 *bending strength (N-m)*—of a bone plate, the bending moment necessary to produce a 0.2 % offset displacement in the bone plate when tested as described in Section A1.8 (the bending moment corresponding to point D in Fig. A1.1.). If the bone plate fractures before the proof point is attained the bending strength shall be defined as the bending moment at fracture.

A1.3.1.3 *bending structural stiffness, (EI<sub>e</sub>) (N-m<sup>2</sup>)*—of a bone plate, the bone plate’s normalized effective bending stiffness that takes into consideration the effects of the test setup’s configuration. For this test method, the bending structural stiffness is determined from the single cycle bending response of the bone plate and the testing configuration.

A1.3.1.4 *bending stiffness, K (N/mm)* —of a bone plate, the maximum slope of the linear elastic portion of the load versus load-point curve when tested as described in section A1.8. (See the slope of line Om in Fig. A1.1).

A1.3.1.5 *bone plate width, w (mm)*—the width of the bone plate as shown in Fig. A1.3.

A1.3.1.6 *center span, a (mm)*—the distance between the two loading rollers as shown in Fig. A1.2.

A1.3.1.7 *fracture load, F<sub>max</sub> (N)*—the applied load at the time when the bone plate fractures.

A1.3.1.8 *loading span, h (mm)*—the distance between the loading roller and the nearest support as shown in Fig. A1.2.

A1.3.1.9 *permanent deformation (mm)* —the vertical displacement of the point of load application remaining after the applied load has been removed.

A1.3.1.10 *proof load, P (N)*—the applied load at the intersection point of line. BC with the load versus load-point displacement curve. (See Fig. A1.1).

A1.3.1.11 *proof point displacement (mm)* —the load-point displacement associated with the bone plate’s bending strength. (See point A in Fig. A1.1).

A1.3.1.12 *total deformation (mm)*—the vertical displacement of the point of application of the load when specified load is applied.

A1.4 Summary of Test Method:

A1.4.1 Bone plates are subjected to a single cycle four-point bending load. The bone plate’s bending stiffness, bending structural stiffness, and bending strength are then derived from the test record generated during the test and the testing configuration.

A1.5 Significance and Use:

A1.5.1 This bend test is used to determine values for the mechanical response of bone plates to a specific type of bending load. The information resulting from this test method can give the surgeon some insight into the mechanical response of a given bone plate.

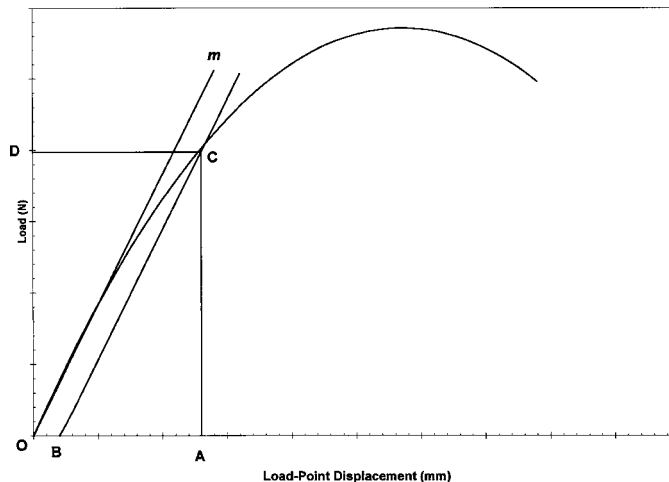

FIG. A1.1 Diagram Illustrating Methods For Determining Bending Properties of Bone Plates

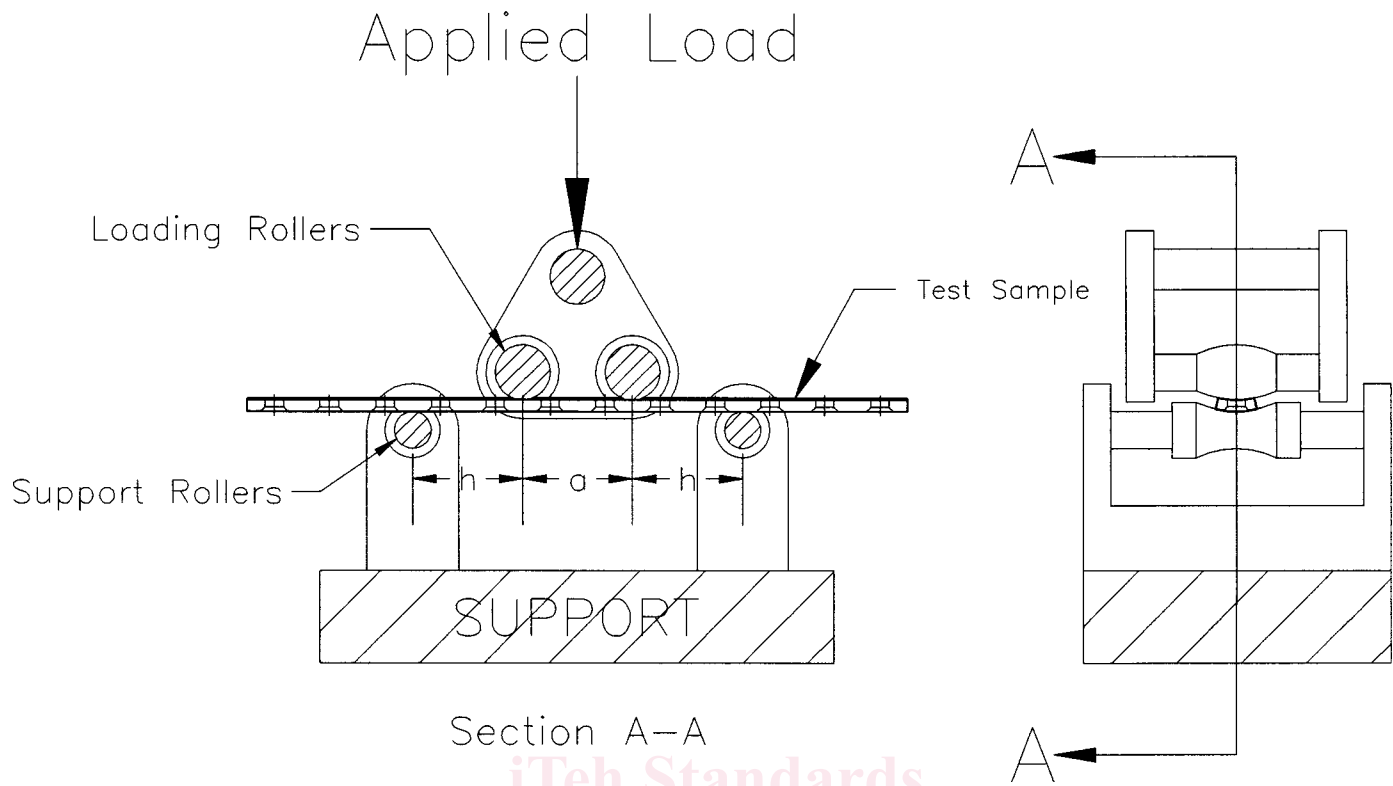

FIG. A1.2 Test Configuration

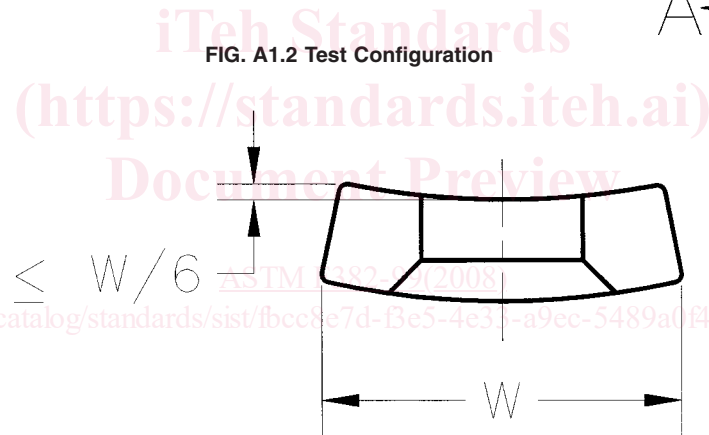

FIG. A1.3 Roller Profiling Requirements

A1.5.2 Since the loading on the bone plate *in situ* will, in general differ from the loading configuration used in this method, the results obtained from this test method cannot be used directly to predict *in vivo* performance of the bone plate being tested. Such mechanical property data can be used to conduct relative comparisons of different bone plate designs.

A1.5.3 The bone plate's bending strength, as defined in Section A1.3.1.2, identifies the bending moment that must be applied to the bone plate in order to produce a specific amount a permanent deformation.

A1.5.4 The bending structural stiffness of the bone plate, as defined in Section A1.3.1.3, is an indicator of the bone plate's stiffness that is independent of the test configuration. Bending structural stiffness is simply related to the bone plate's geometry and the material used in manufacturing the bone plate.

A1.5.5 This test method assumes that linear-elastic material behavior will be observed and therefore, the method is not applicable for the testing of materials that exhibit non-linear elastic behavior.

A1.6 Apparatus:

A1.6.1 The typical test configuration is illustrated in Fig. A1.2.

A1.6.1.1 All loads shall be applied through rollers of equal diameters within the range of 6 to 12 mm. The selected roller diameter should not be greater than the distance between two adjacent screw holes in the bone plate to be tested.

A1.6.1.2 Cylindrical rollers shall be used to test flat bone plates and bone plates of curved cross-section, in which the deviation from flatness at the center of the bone plate does not exceed  $w/6$ . Test other bone plates using rollers of profiled form corresponding to the cross-section of the bone plate to be tested (see Fig. A1.3).