



Designation: B215 – 08

Standard Practices for Sampling Metal Powders¹

This standard is issued under the fixed designation B215; the number immediately following the designation indicates the year of original adoption or, in the case of revision, the year of last revision. A number in parentheses indicates the year of last reapproval. A superscript epsilon (ϵ) indicates an editorial change since the last revision or reapproval.

This standard has been approved for use by agencies of the Department of Defense.

1. Scope*

1.1 These practices describe two procedures for obtaining samples of metal powders for subsequent testing:

1.1.1 *Practice A*—For powders being transferred from blenders or storage tanks.

1.1.2 *Practice B*—For powders already packaged in containers.

1.2 *This standard does not purport to address all of the safety concerns, if any, associated with its use. It is the responsibility of the user of this standard to establish appropriate safety and health practices and determine the applicability of regulatory limitations prior to use.*

2. Referenced Documents

2.1 *ASTM Standards*:²

B243 Terminology of Powder Metallurgy

3. Terminology

3.1 *Definitions*—Definitions of powder metallurgy terms can be found in Terminology **B243**. Additional descriptive information is available in the Related Materials section of Vol 02.05 of the *Annual Book of ASTM Standards*.

3.2 *Description of Terms* (see Fig. 1):

3.2.1 *increment*—quantity of powder obtained by a sampling device at one time from a single lot.

3.2.2 *gross sample*—quantity of powder adequate for the tests to be performed, consisting of all the increments taken from a single lot.

3.2.3 *composite sample*—blended entire gross sample.

3.2.4 *test sample*—quantity of powder taken from the composite sample for determining a single property or for preparing the test pieces. It should normally be taken by splitting the composite sample.

¹ These practices are under the jurisdiction of ASTM Committee B09 on Metal Powders and Metal Powder Products and are the direct responsibility of Subcommittee B09.02 on Base Metal Powders.

Current edition approved Nov. 1, 2008. Published December 2008. Originally approved in 1946. Last previous edition approved in 2004 as B215–04. DOI: 10.1520/B0215-08.

² For referenced ASTM standards, visit the ASTM website, www.astm.org, or contact ASTM Customer Service at service@astm.org. For *Annual Book of ASTM Standards* volume information, refer to the standard's Document Summary page on the ASTM website.

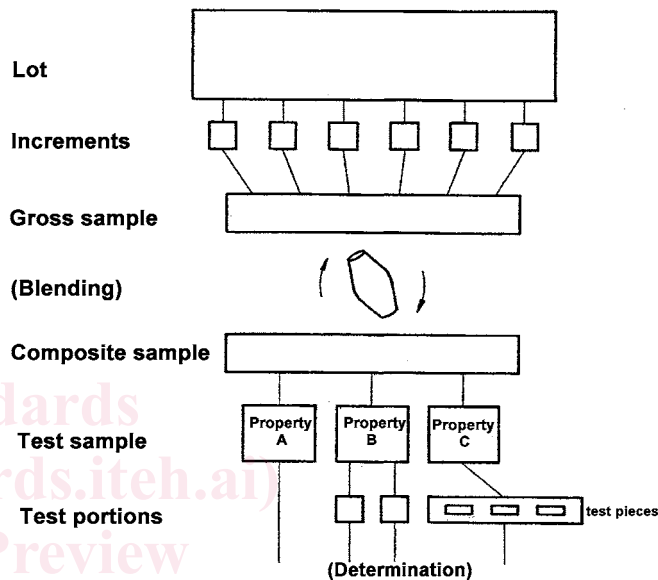

FIG. 1 Scheme of Sampling

3.2.5 *test portion (test specimen)*—defined quantity of powder taken from the test sample on which the test is performed or from which test pieces are produced.

4. Significance and Use

4.1 Since many tests are performed using very small amounts of powder, it is most important that the test portions be obtained in a standardized manner. The practices described here take into account the possibility of segregation of the metal powder during and after filling of containers.

PRACTICE A

FOR POWDERS BEING TRANSFERRED FROM BLENDERS OR STORAGE TANKS

5. Apparatus

5.1 *Rectangular Receptacle*, capable of being moved completely across the stream of flowing powder at a constant speed and having a length and width greater than the stream of powder. It must be large enough so that no overflow of powder occurs when collecting the sample.

*A Summary of Changes section appears at the end of this standard.

PRACTICE B

FOR POWDERS ALREADY PACKAGED IN CONTAINERS

- 5.2 *Small Blender.*
- 5.3 *Sample Splitter, see Fig. 2.*
- 5.4 *Spinning Riffler, see Fig. 3.*

6. Procedure

6.1 Pass the rectangular receptacle at a constant speed completely through the stream of flowing powder. If the entire contents of one lot of powder are being packed in a single container, take increments when the container is $\frac{1}{4}$, $\frac{1}{2}$, and $\frac{3}{4}$ filled. If several containers are to be filled by one lot of powder, take the first increment when the first container is $\frac{1}{2}$ filled, the second increment in the middle of the run, and the third increment near the end of the run. Additional increments may be agreed upon by the parties concerned. The total amount from all increments shall be adequate for the tests to be performed. Combine the increments to obtain the gross sample.

NOTE 1—To investigate within-lot variability, individual increments may be tested rather than being combined to form a composite sample.

6.2 Blend the gross sample in a small blender for 10 to 15 revolutions to form a composite sample.

6.3 Pass the composite sample through a sample splitter or spinning riffler to obtain the test samples.

6.4 Obtain the test portion from the test sample by use of a sample splitter, or a sample spinning riffler.

7. Frequency of Increments

7.1 Take at least three increments for each lot of powder. The actual number depends on the size of the lot and the powder involved and shall be agreed upon by the parties involved.

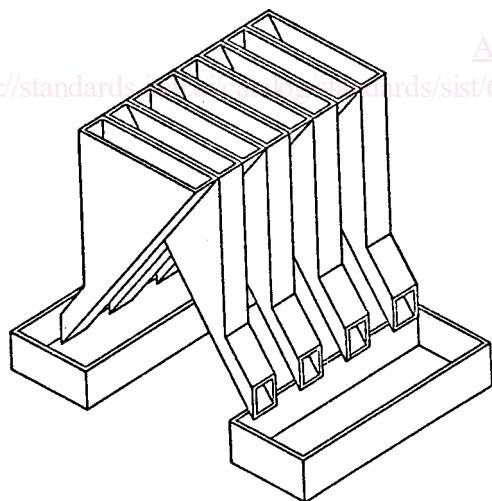

FIG. 2 Sample Splitter

8. Apparatus

- 8.1 *Keystone Sampler, see Fig. 4.*
- 8.2 *Small Blender.*
- 8.3 *Sample Splitter, see Fig. 2.*
- 8.4 *Spinning Riffler, see Fig. 3.*

9. Procedure

9.1 Insert the Keystone sampler in the closed position into the powder at a point 70 % of the distance from the center of the cross section to the periphery and straight down to the bottom of the container. Then twist the sampler to the open position allowing powder to flow into the sampler. Close the sampler tube when filled and remove it from the container. Empty the contents of the sample either into a container or onto a sheet of glazed or waxed paper.

9.2 When a suitable number of increments have been taken, combine them to obtain the gross sample and blend them for 10 to 15 revolutions to obtain a composite sample.

NOTE 2—To investigate within-lot variability, individual increments may be tested rather than being combined to form a composite sample.

9.3 Pass the composite sample through a sample splitter or spinning riffler to obtain the test samples.

9.4 Obtain the test portion from the test sample by use of a sample splitter or a sample spinning riffler.

10. Frequency of Increments

10.1 See Table 1.

TABLE 1 Frequency of Increments

No. of Containers in the Lot	No. of Containers to be Sampled (Randomly Selected)
1 to 5	all
6 to 11	5
12 to 20	6
21 to 35	7
36 to 60	8
61 to 99	9
100 to 149	10
150 to 199	11
200 to 299	12
300 to 399	13
More than 400	13 + 1 per 100 additional containers

11. Keywords

11.1 blender; composite sample; Keystone sampler; sample splitter; sampling segregation