

---

---

**Graphic technology — Test method  
for the determination of the binding  
strength for perfect-bound products  
— Page-pull test working upwards**

*Technologie graphique — Méthodes d'essai pour la détermination de  
la force de fixation des produits à reliure collée — Essai de traction de  
page vers le haut*

iTeh STANDARD PREVIEW  
(standards.iteh.ai)

[ISO 19594:2017](https://standards.iteh.ai/catalog/standards/sist/5099e200-3a57-444d-90ec-c82c2046be9b/iso-19594-2017)

<https://standards.iteh.ai/catalog/standards/sist/5099e200-3a57-444d-90ec-c82c2046be9b/iso-19594-2017>



**iTeh STANDARD PREVIEW**  
**(standards.iteh.ai)**

ISO 19594:2017

<https://standards.iteh.ai/catalog/standards/sist/5099e200-3a57-444d-90ec-c82c2046be9b/iso-19594-2017>



**COPYRIGHT PROTECTED DOCUMENT**

© ISO 2017, Published in Switzerland

All rights reserved. Unless otherwise specified, no part of this publication may be reproduced or utilized otherwise in any form or by any means, electronic or mechanical, including photocopying, or posting on the internet or an intranet, without prior written permission. Permission can be requested from either ISO at the address below or ISO's member body in the country of the requester.

ISO copyright office  
Ch. de Blandonnet 8 • CP 401  
CH-1214 Vernier, Geneva, Switzerland  
Tel. +41 22 749 01 11  
Fax +41 22 749 09 47  
copyright@iso.org  
www.iso.org

# Contents

	Page
<b>Foreword</b> .....	<b>iv</b>
<b>Introduction</b> .....	<b>v</b>
<b>1 Scope</b> .....	<b>1</b>
<b>2 Normative references</b> .....	<b>1</b>
<b>3 Terms and definitions</b> .....	<b>1</b>
<b>4 Principle</b> .....	<b>2</b>
<b>5 Apparatus</b> .....	<b>2</b>
5.1 Material testing system.....	2
5.2 Test fixture.....	3
5.2.1 Equipment on the upper traverse.....	3
5.2.2 Downholder.....	4
<b>6 Test preparation</b> .....	<b>5</b>
6.1 General.....	5
6.2 Sampling.....	6
6.3 Conditioning.....	6
6.4 Insertion of the specimen.....	6
6.5 Application of the preload.....	7
6.6 Fixing the test sheet.....	8
6.7 Execution of the pull procedure.....	9
6.8 Calculation of the binding strength.....	10
6.9 Calculation of the coefficient of variation.....	10
<b>7 Precision</b> .....	<b>11</b>
<b>8 Report</b> .....	<b>11</b>
<b>Annex A (informative) Quality levels for the binding strength based on page-pull tests</b> .....	<b>12</b>
<b>Annex B (informative) Quality levels for the consistency of the binding quality</b> .....	<b>13</b>
<b>Bibliography</b> .....	<b>14</b>

## Foreword

ISO (the International Organization for Standardization) is a worldwide federation of national standards bodies (ISO member bodies). The work of preparing International Standards is normally carried out through ISO technical committees. Each member body interested in a subject for which a technical committee has been established has the right to be represented on that committee. International organizations, governmental and non-governmental, in liaison with ISO, also take part in the work. ISO collaborates closely with the International Electrotechnical Commission (IEC) on all matters of electrotechnical standardization.

The procedures used to develop this document and those intended for its further maintenance are described in the ISO/IEC Directives, Part 1. In particular the different approval criteria needed for the different types of ISO documents should be noted. This document was drafted in accordance with the editorial rules of the ISO/IEC Directives, Part 2 (see [www.iso.org/directives](http://www.iso.org/directives)).

Attention is drawn to the possibility that some of the elements of this document may be the subject of patent rights. ISO shall not be held responsible for identifying any or all such patent rights. Details of any patent rights identified during the development of the document will be in the Introduction and/or on the ISO list of patent declarations received (see [www.iso.org/patents](http://www.iso.org/patents)).

Any trade name used in this document is information given for the convenience of users and does not constitute an endorsement.

For an explanation on the meaning of ISO specific terms and expressions related to conformity assessment, as well as information about ISO's adherence to the World Trade Organization (WTO) principles in the Technical Barriers to Trade (TBT) see the following URL: [www.iso.org/iso/foreword.html](http://www.iso.org/iso/foreword.html).

The committee responsible for this document is ISO/TC 130, *Graphic technology*.

[ISO 19594:2017](https://standards.iteh.ai/catalog/standards/sist/5099e200-3a57-444d-90ec-c82c2046be9b/iso-19594-2017)

<https://standards.iteh.ai/catalog/standards/sist/5099e200-3a57-444d-90ec-c82c2046be9b/iso-19594-2017>

## Introduction

Perfect binding is the most frequently used block-binding technique for brochures and books. The page-pull test, the only established method for the quality assessment of perfect bindings available today, plays an important role in the process control and quality verification.

The page-pull test has historically been performed using different procedures and devices. Test results<sup>[5]</sup> showed significant variations between devices. This document aims to harmonize the testing procedure, the testing equipment and the evaluation of the test results.

Within a research project, the following essential test parameters were identified as influencing the test results of page-pull tests<sup>[1]</sup>:

- test position (front, middle or rear part of the book block);
- specimen alignment in relation to the pull force direction;
- specimen opening and fixing during the page-pull test.

There are many products showing homogeneous test results independent of the test position. However, there are also products showing differences within the book block, even including sheet-to-sheet deviations. Therefore, it is recommended that there should be agreement on page-specific test positions and that these should be communicated with the particular results.

Book blocks show large differences in their opening behaviour. Products with a significant clamp usually show no differences of the test sheet alignment in different test positions. Products with a good lay-flat behaviour usually show significant bending of the test sheet in the area of the spine if tested in a non-centered test position. To avoid known measurement errors, a straight alignment of the test sheet is essential. A technical means to ensure this is the possibility to tilt the opened book block depending on the particular test position.

Non-specified loads on specimens need to be avoided to ensure the absence of preliminary stress on the binding. Therefore, the opening process of the specimen needs to be controlled. The opening angle of the specimen may be standardized by the shape of a book block opening device. The intensity of the opening is determined by the force applied during the opening process and the shape of the device. These settings influence the degree of freedom of movement of the specimen during the page-pull test procedure and thus the warping of the spine. A too low degree of freedom leads to an unrealistically frequent occurrence of paper ruptures, while the opposite may lead to a lifting of the whole book block. The provisions for the opening and fixing of the specimen are realized within this document by the definition of the shape and the force of a downholder. These settings have a significant influence on the test results.

The page-pull speed within a reasonable range, shows no significant influence on the test results. Therefore, in harmonization with ISO 1924-2, the page-pull speed was chosen to be 20 mm/min. This condition results in a non-linear force development during the test.

The test results need to be evaluated in a consistent manner. An evaluation schema that has been proven by long industry practice is given in [Annex A](#).

Devices performing the page-pull test by pulling downwards create different measurement values from those pulling upwards. This results from the different block positioning due to gravity and the mass of the book block.

The pull test described in this document was developed to ensure a high level of reproducibility and comparability between laboratories. For internal quality assurance during production, devices with a lesser degree of comparability may be used.

**iTeh STANDARD PREVIEW**  
**(standards.iteh.ai)**

ISO 19594:2017

<https://standards.iteh.ai/catalog/standards/sist/5099e200-3a57-444d-90ec-c82c2046be9b/iso-19594-2017>

# Graphic technology — Test method for the determination of the binding strength for perfect-bound products — Page-pull test working upwards

## 1 Scope

This document specifies a test method for the determination of the binding strength of perfect-bound products by pulling out single sheets from the book block in an upward direction.

## 2 Normative references

The following documents are referred to in the text in such a way that some or all of their content constitutes requirements of this document. For dated references, only the edition cited applies. For undated references, the latest edition of the referenced document (including any amendments) applies.

ISO 186, *Paper and board — Sampling to determine average quality*

ISO 187, *Paper, board and pulps — Standard atmosphere for conditioning and testing and procedure for monitoring the atmosphere and conditioning of samples*

ISO 2859-1, *Sampling procedures for inspection by attributes — Part 1: Sampling schemes indexed by acceptance quality limit (AQL) for lot-by-lot inspection*

## 3 Terms and definitions

For the purposes of this document, the following terms and definitions apply.

ISO and IEC maintain terminological databases for use in standardization at the following addresses:

- IEC Electropedia: available at <http://www.electropedia.org/>
- ISO Online browsing platform: available at <http://www.iso.org/obp>

### 3.1

#### **binding strength**

quality measure of the binding quality of a perfect-bound product

Note 1 to entry: Ratio between the pull-out force of a single sheet and the spine length.

### 3.2

#### **book block**

part of a case-bound book or brochure, consisting of a trimmed or untrimmed bound block of sheets, prior to the application of the book case or cover

### 3.3

#### **glue penetration**

uncontrolled and inhomogeneous penetration (several millimetres) of glue between the sheets of a *book block* (3.2)

### 3.4

#### **special sheet**

sheet of the book block with potentially different properties from those of the majority of the sheets of that *book block* (3.2)

### 3.5

#### **specimen**

single test object, consisting either of a perfect-bound book (soft cover), a case-bound book (hard cover) or a perfect-bound *book block* (3.2) (intermediate product)

### 3.6

#### **spine length**

length of the spine of a *book block* (3.2), equal to the height of the book block

### 3.7

#### **test fixture**

apparatus to fix the *specimen* (3.5) on the test device during testing

### 3.8

#### **test position**

position of the *test sheet* (3.9) given as a percentage of the total number of pages

### 3.9

#### **test sheet**

sheet of the *book block* (3.2) chosen to be tested according to this document

## 4 Principle

The binding strength is evaluated by pulling out a single sheet from the book block using a material testing system and a specified test fixture. The test is performed in such a way that the test sheet is clamped on the complete fore edge while the opened book block is fixed at the specimen holder with a specified preload. The test sheet is pulled out upwards by a force acting perpendicular to the binding edge. The maximum force resulting from the pull-out procedure is measured. The binding strength of the specimen is calculated by dividing the maximum force by the spine length of the book block.

<https://standards.iteh.ai/catalog/standards/sist/5099e200-3a57-444d-90ec-c82c2046be9b/iso-19594-2017>

## 5 Apparatus

### 5.1 Material testing system

The material testing system shall be constructed as a twin-column device that shall be able to perform tensile testing and to apply a preload. It contains an upper moveable traverse, where the force transducer is located. The horizontal working space of the material testing system is determined by the maximum spine length of the products tested. A scheme of the material testing system, including the test fixture (see 5.2), is shown in [Figure 1](#).



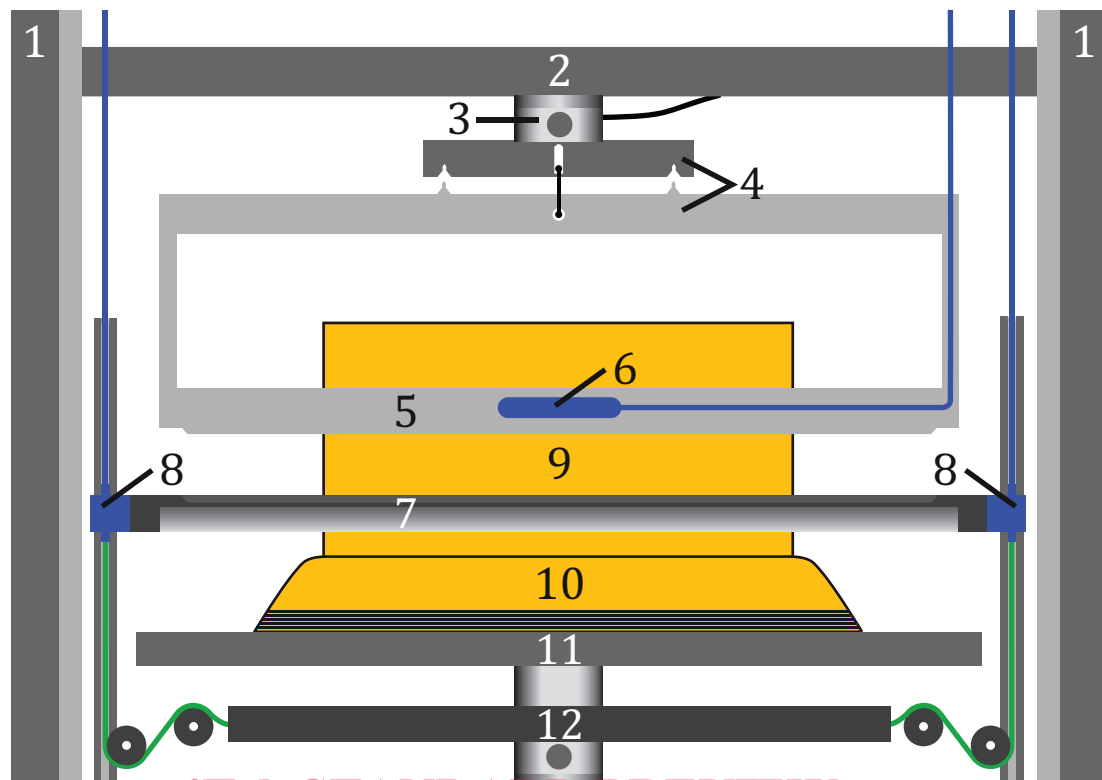

iTeh STANDARD PREVIEW  
(standards.iteh.ai)

#### Key

1	load frame	7	downholder
2	upper traverse	8	downholder locking mechanism (e.g. pneumatic)
3	force transducer	9	test sheet
4	vertical guide	10	specimen (bound product)
5	sheet clamping unit	11	specimen holder
6	sheet clamping mechanism (e.g. pneumatic)	12	counterweight of the downholder

Figure 1 — Scheme of the page pull-test device

## 5.2 Test fixture

### 5.2.1 Equipment on the upper traverse

#### 5.2.1.1 Vertical guide

The vertical guide is positioned between the force transducer and the sheet clamping unit. The vertical guide consists of two parts. The connection between the two parts consists of a centered compensator and means of alignment on both sides. During the application of the preload, both parts lock positively and they are therefore rigid. During tensile testing, both parts are unlocked and flexible to allow tilting.

#### 5.2.1.2 Sheet clamping unit

The sheet clamping unit is positioned between the vertical guide and the downholder. The sheet clamping unit consists of two bars designed to clamp the test sheet. During testing, the two bars are closed with a gap remaining. For clamping the test sheet, this gap will be closed. The clamping position of the test sheet shall not change during the test (no slippage).

The clamping procedure may be performed either manually or automatically.

**5.2.2 Downholder**

The downholder is a separate bar that is used to fix the opened book block on the specimen holder. It shall contain a gap to allow for the feeding through of the test sheet.

The downholder may be constructed as two separate bars with a hinge to make it easier to feed through the test sheet.

The essential part of the downholder is shown in [Figure 2](#).

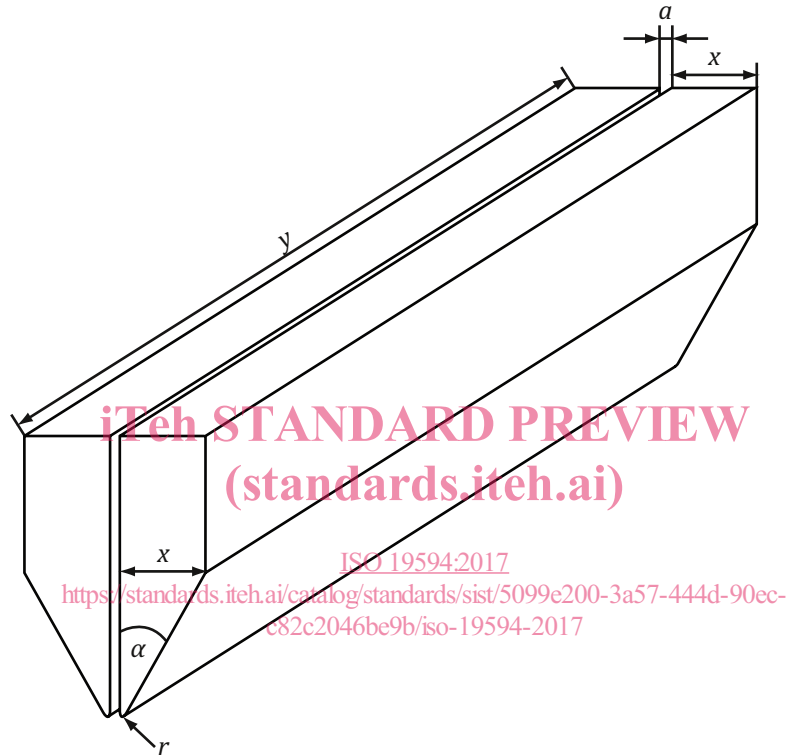

**Figure 2 — Dimensions of the downholder**

**Key**

- $y$  >297 mm
- $x$  10 mm ± 0,5 mm
- $a$  2 mm ± 0,3 mm
- $r$  2 mm ± 0,3 mm
- $\alpha$  30° ± 1°

The downholder shall be adjustable in vertical direction and shall be fixed horizontally, parallel to the specimen holder. The vertical position of the downholder during testing shall be fixable. The clamping position of the downholder shall not change during the test.

The clamping procedure may be performed either manually or automatically (e.g. pneumatically).

NOTE For material testing systems with two moveable traverses, the downholder can be vertically non-adjustable.

To prevent adverse influences on the measurement results, uncontrolled resting of the downholder on the book block shall be avoided.

This may be achieved by a mass-compensated mounting of the downholder.

### 5.2.3 Specimen holder

The support for the book block shall enable a rectangular alignment of the page pulled and the spine according to [Figure 3](#). This shall either be performed by using additional appropriate supporting devices or preferentially by supports consisting of two horizontal plates. If the height alignment is performed by supports consisting of two horizontal plates, the facing edges of both plates shall be located perpendicularly below the gaps of the downholder and the sheet clamping unit. At least one of the plates shall allow continuous vertical adjustment and fixing in place. The vertical distance between the two plates shall be measurable. The plates shall be strong enough to show no bending under the combined load of the book block and the preload. The surface of the plates shall be smooth enough to allow a horizontal alignment of the specimen during the test procedure.

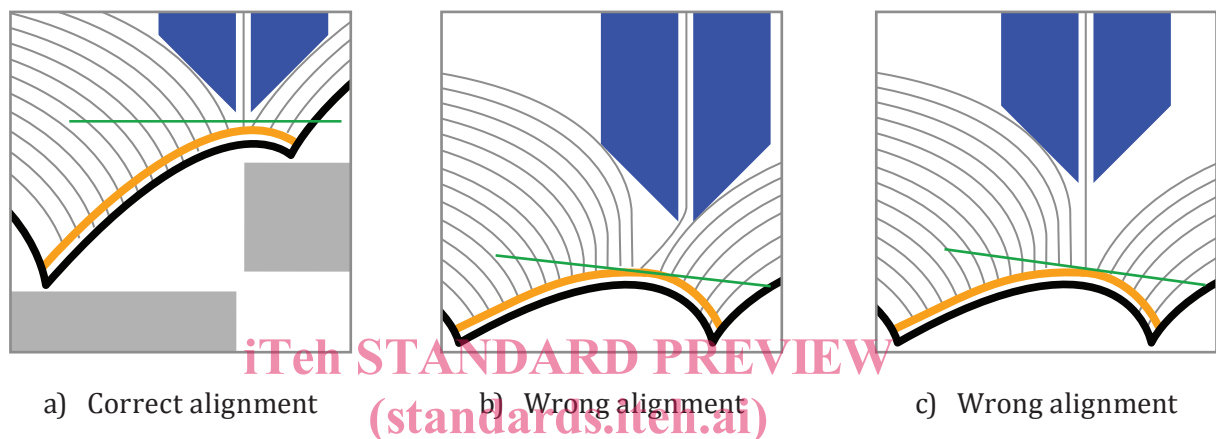

**Figure 3 — Alignment of the test sheet and the spine with respect to the pulling direction**

### 5.3 Calibration and adjustment of apparatus

The apparatus shall be able to be calibrated and shall be calibrated according to the manufacturer's guidelines and specifications. Verification of calibrated status should be made prior to any test being performed.

## 6 Test preparation

### 6.1 General

The aim of the testing of book blocks is to identify possible weaknesses in the binding quality. The number of samples tested depends on the thickness of the book block and the number of special sheets.

This test shall be performed with a sufficient time between production and testing to allow the full binding strength of the glue to be achieved. In addition, separate book blocks shall be used for each sample tested.

For book blocks with a thickness of at least 10 mm, there shall be a minimum of three sample sheets tested. These test sheets shall be located at 10 %, 50 % and 90 % of the total number of pages.

NOTE For example, for a book block of 100 pages, the test sheets are pages 10, 50 and 90.

For book blocks with a thickness less than 10 mm, there shall be at least one sheet tested.

In addition, each type of special sheet included in the book block shall be tested at least once. Special sheets are:

- sheets of differing type or thickness compared to the majority of the sheets;