



Designation: D 5438 – 00

Standard Practice for Collection of Floor Dust for Chemical Analysis¹

This standard is issued under the fixed designation D 5438; the number immediately following the designation indicates the year of original adoption or, in the case of revision, the year of last revision. A number in parentheses indicates the year of last reapproval. A superscript epsilon (ϵ) indicates an editorial change since the last revision or reapproval.

1. Scope

1.1 This practice covers a procedure for the collection of a sample of dust from carpets and bare floors that can be analyzed for lead, pesticides, or other chemical compounds and elements.

1.2 This practice is applicable to a variety of carpeted and bare floor surfaces. It has been tested for level loop and plush pile carpets and bare wood floors, specifically.

1.3 This practice is not intended for the collection and evaluation of dust for the presence of asbestos fibers.

1.4 The values stated in SI units are to be regarded as the standard.

1.5 *This standard does not purport to address all of the safety concerns, if any, associated with its use. It is the responsibility of the user of this standard to establish appropriate safety and health practices and determine the applicability of regulatory limitations prior to use.*

2. Referenced Documents

2.1 ASTM Standards:

D 422 Test Method for Particle-Size Analysis of Soils²

D 1356 Terminology Relating to Sampling and Analysis of Atmospheres³

E 1 Specification for ASTM Thermometers⁴

E 337 Test Method for Measuring Humidity with a Psychrometer (the Measurement of Wet- and Dry-Bulb Temperatures)³

F 608 Test Method for Evaluation of Carpet-Embedded Dirt Removal Effectiveness of Household Vacuum Cleaners⁵

3. Terminology

3.1 *Definitions*—For definitions of terms used in this practice, refer to Terminology D 1356.

3.1.1 *carpet-embedded dust*—soil and other particulate matter, approximately 5- μ m equivalent aerodynamic diameter and

larger, embedded in carpet pile and normally removable by household vacuum cleaners.

3.1.2 *surface dust*—soil and other particulate matter, approximately 5- μ m equivalent aerodynamic diameter and larger, adhering to floor surfaces and normally removable by household vacuum cleaners.

4. Summary of Practice

4.1 The sampling method described in this practice is taken from work published in Roberts, et al,^{6,7,8} and Stamper, et al.⁹

4.2 Particulate matter is withdrawn from the carpet or bare floor by means of a flowing air stream passing through a sampling nozzle at a specific velocity and flow rate and separated mechanically by a cyclone. The cyclone collects efficiently particles approximately 5- μ m mean aerodynamic diameter and larger. The sampling system allows for height, air flow, and suction adjustments to reproduce systematically a specific air velocity for the removal of particulate matter from carpeted and bare floor surfaces, so that these sampling conditions can be repeated.

NOTE 1—Side-by-side comparison of the HVS3 and a conventional upright vacuum cleaner revealed that both collected particles down to at least 0.2 μ m and that the HVS3 was more efficient at collecting particles smaller than 20 μ m than conventional vacuum cleaners.¹⁰ If desired, a fine-particle filter may be added downstream of the cyclone to collect 99.9 % of particles above 0.2 μ m aerodynamic mean diameter.

¹ This practice is under the jurisdiction of ASTM Committee D22 on Sampling and Analysis of Atmospheres and is the direct responsibility of Subcommittee D22.05 on Indoor Air.

Current edition approved March 10, 2000. Published June 2000. Originally published as D 5438 – 93. Last previous edition D 5438 – 94.

² *Annual Book of ASTM Standards*, Vol 04.08.

³ *Annual Book of ASTM Standards*, Vol 11.03.

⁴ *Annual Book of ASTM Standards*, Vol 14.03.

⁵ *Annual Book of ASTM Standards*, Vol 15.07.

⁶ Roberts, J. W., Budd, W. T., Ruby, M. G., Stamper, V. R., Camann, D. E., Fortman, R. C., Sheldon, L. S., and Lewis, R. G., "A Small High Volume Surface Sampler HVS3 for Pesticides, and Other Toxic Substances in House Dust," *Paper No. 91-150.2*, 84th Annual Meeting, Air & Waste Management Association, Vancouver, British Columbia, June 16–21, 1991.

⁷ Roberts, J. W., and Ruby, M. G., "Development of a High Volume Surface Sampler for Pesticides," *U.S. Environmental Protection Agency Report No. EPA 600/4-88/036*, Research Triangle Park, NC, January 1989.

⁸ Roberts, J. W., Han, W., and Ruby, M. G., "Evaluation of Dust Samplers for Bare Floors and Upholstery," Battelle Subcontract No. 46534(g21733808)-00 03EQ, EPA Prime Contract No. 68-00-0007, U.S. EPA, AREAL, Office of Research and Development, 1993.

⁹ Stamper, V. R., Roberts, J. W., and Ruby, M. G., "Development of a High Volume Small Surface Sampler for Pesticide and Toxics in House Dust," *Research Triangle Institute Report No. RTI/171-01/02F*, Research Triangle Park, NC, June 1990. Included in supporting data, which are on file at ASTM Headquarters. Request RR:D22-1010.

¹⁰ Willis, R. D., "SEM Characterization of House Dusts Collected by Conventional Vacuum and the HVS3 Sampler." Report to the U.S. EPA under Contract 68-D5-0049, Research Triangle Park, NC, ManTech Environmental Technology, Inc., 1995.

4.3 The particulate matter in the air stream is collected in a catch bottle attached to the bottom of the collection cyclone. This catch bottle shall be capped for storage of the sample and transported to the laboratory for analysis.

5. Significance and Use

5.1 This practice may be used to collect dust from carpeted or bare floor surfaces for gravimetric or chemical analysis. The collected sample is substantially unmodified by the sampling procedure.

7.1.1 The dimensions of the sampling apparatus (nozzle size, cyclone diameter, cyclone inlet diameter, etc.) are interdependent. The flow rate must produce a sufficient velocity both at the sampled surface and in the cyclone. The cyclone must have a cut diameter of 5 μm at the same velocity that will provide a horizontal velocity of 40 cm/s at 10 mm from the nozzle in the carpet material, or 5 mm from the nozzle on bare floors. The fundamental principles of this device have been discussed in detail in Roberts, et al.^{6,7,8}

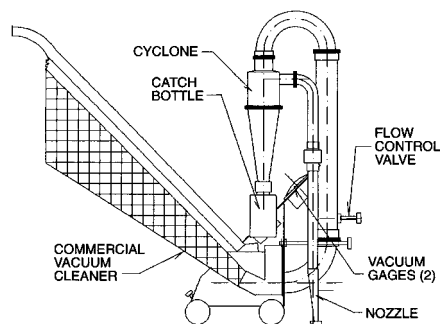

FIG. 1 Floor Dust Sampler Using a Commercial Vacuum Cleaner as the Suction Source

5.2 This practice provides for a reproducible dust removal rate from level loop and plush carpets, as well as bare floors. It has the ability to achieve relatively constant removal efficiency at different loadings of surface dust.

5.3 This practice also provides for the efficient capture of semivolatile organic chemicals associated with the dust. The test system can be fitted with special canisters downstream of the cyclone for the capture of specific semivolatile organic chemicals that may volatilize from the dust particles during collection.

5.4 This practice does not describe procedures for evaluation of the safety of floor surfaces or the potential human exposure to carpet dust. It is the user's responsibility to evaluate the data collected by this practice and make such determinations in the light of other available information.

6. Interferences

6.1 There are no known interferences to the determination of dust loadings covered by this practice.

7. Apparatus

7.1 *Sampling Apparatus*, which may be acquired commercially¹¹ (as shown in Fig. 1) or constructed as follows:

7.1.2 *Nozzle*—The edges and corners of the sampling nozzle shall be rounded to prevent catching the carpet material. The nozzle must be constructed to allow for sufficient suction to separate loose particles from the carpet or bare floor and carry them to the cyclone. It must have an adjustment mechanism to establish the nozzle lip parallel to the surface and to achieve the proper suction velocity and pressure drop across the nozzle. A nozzle 12.4 cm long and 1 cm wide, with a 13-mm flange and tapered to the nozzle tubing at no more than 30°, will yield the appropriate velocities when operated as specified in Section 11.

7.1.3 *Gaskets*—Gaskets in joints should be of a material appropriate to avoid sample contamination.

7.1.4 *Cyclone*—The cyclone shall be of a specific size such that a given air flow allows for separation of the particles 5-μm mean aerodynamic diameter and larger. The cyclone must be made of aluminum or stainless steel, and the catch bottle must be made of clear glass or fluorinated ethylene propylene (FEP) to avoid contamination and allow the operator to see the sample.

7.1.5 *Flow Control System*—The flow control system shall allow for substantial volume adjustment. The suction source must be capable of drawing 12 L/s (26.5 CFM) through the system with no restrictions other than the nozzle, cyclone, and flow control system connected. An upright commercial vacuum cleaner with a 7 amp or greater motor capable of pulling a vacuum of 6.5 kPa may be used for this purpose.

7.1.6 *Flow Measuring and Suction Gages*—Two vacuum gages are required — one with a range of 0 to 3.7 kPa (0–15 in. water) is used for setting flow rate and another with a range

¹¹ The sampling device used in the development and performance evaluation of this test method was manufactured by CS-3, Inc., P.O. Box 1461, Sandpoint, ID 83864, which is the sole source of supply of the sampler known to the committee at this time. If you are aware of alternative suppliers, please provide this information to the Committee on Standards, ASTM Headquarters, 100 Barr Harbor Dr., West Conshohocken, PA 19428. Your comments will receive careful consideration at a meeting of the responsible technical committee, which you may attend.

of 0 to 2.5 kPa (0–10 in. water) is used to set the pressure drop across the vacuum nozzle.

7.1.7 Optional filter holder assembly with appropriate fine particle filter, such as a 25-cm micro-quartz-fibre, binderless, acid-washed filter.¹²

7.2 Other Equipment:

7.2.1 *Stopwatch.*

7.2.2 *Masking Tape and Marking Pen*, for outlining sections for sampling.

7.2.3 *Clean Aluminum Foil and Clean Glass or FEP Jars*, for the collection and storage of samples.

7.2.4 *Thermometer* (see Specification E 1).

7.2.5 *Relative Humidity Meter* (see Test Method E 337).

7.2.6 *Shaker Sieve*, as specified in Test Method D 422, with 100 mesh-screen above the pan to separate the fine dust below 150 μm .

7.2.7 *Analytical Balance*, sensitive to at least 0.1 mg and having a weighing range from 0.1 mg to 1000 g.

8. Reagents and Materials

8.1 *Purity of Reagents*—Reagent grade chemicals shall be used in all tests. Unless otherwise indicated, it is intended that all reagents shall conform to the specifications of the Committee on Analytical Reagents of the American Chemical Society, where such specifications are available.¹³

8.2 Methanol is required for sampling train cleaning after sample collection.

9. Sampling Strategy

9.1 The overall sampling strategy should be designed to address the goals of the study. Users should consider factors such as foot traffic volume, types of activities, proximity to potential sources, etc. The sampling strategy should be described in the sampling report so it can be taken into consideration when readers are comparing loadings or concentrations, or both, to those obtained from other studies. The ideal sampling location(s) for the beginning of the test procedure are an area that conforms with the protocol for the user's overall sampling strategy. For example, when sampling in a home for child exposure assessment, protocol may require the selection of a carpeted area for sampling where small children play or are likely to play.

10. Pretest Preparation and Calibration

10.1 *Calibration*—The sampling system described in this practice does not have any calibrated flow devices other than the cyclone and the Magnehelic gages. The cyclone used for the separation of the particles must be designed to give proper separation at varying flow rates throughout the sampling range of the system. The pressure gages and any other devices (that

is, temperature gage) used for testing purposes should be calibrated against a primary standard.

10.1.1 *Pressure Gages*—Pressure gages shall be calibrated against an inclined manometer or other primary standard prior to any field test. One means of checking a Magnehelic gage is to set a flow rate through the sampling system with a manometer and then switch to the Magnehelic gage. If the difference in the readings is more than 3 %, the gage is leaking or is in need of repair or calibration. This should be done at two different flow rates when checking the gage.

10.1.2 The cyclone flow measurement is calibrated with a laminar flow element, spirometer, or roots meter. See the appendix for cyclone calibration with a laminar flow element.

10.2 Pretest Preparation:

10.2.1 Each catch bottle to be used shall be clean and inspected for any contamination. The bottles should be marked with masking tape and a marking pen for identification of the test site, time, and date.

10.2.2 The sampling train shall be inspected to ensure that it has been cleaned and assembled properly.

10.2.3 The sampling train shall be leak-checked prior to sampling. This can be accomplished by placing a mailing envelope or a piece of cardboard beneath the nozzle and switching on the suction source. The flow Magnehelic gage should read 5 Pa (0.02 in. H₂O) or less to ensure that the system is leak free. If any leakage is detected, the system shall be inspected for the cause and corrected before use.

11. Sampling

11.1 Sampling a Carpeted Floor:

11.1.1 *Pre-Test Survey*—Immediately prior to testing, complete a data form recording all requested information and sketch the area to be sampled. (See Fig. 2 for a sample data form.)

11.1.2 Select a sampling area according to the established protocol for your sampling campaign. This should be determined prior to testing.

11.1.3 A typical sampling procedure may use measuring tapes placed on the carpet so that they are parallel to each other and on either side of the portion of carpet to be sampled (Fig. 3). The measuring tapes should be between 0.5 and 1.5-m apart and extended as far as practical. They should be taped to the carpet with masking tape every 30 cm.

11.1.4 Place the sampler in one corner of the sampling area and adjust the flow rate and pressure drop according to the type of carpet (see 11.8). The two factors that affect the efficiency of the sampling system are the flow rate and pressure drop at the nozzle. The pressure drop at the nozzle is a function of the flow rate and distance between the surface and the nozzle flange.

11.1.5 Clean the wheels and nozzle lip with a clean laboratory tissue immediately before sampling. Begin sampling by moving the nozzle between the ends of the two measuring tapes. The sampler is then moved back and forth four times on the first strip, moving the sampler at approximately 0.5 m/s. (The widths of the strips are defined by the width of the sampling nozzle.) Effective nozzle width is 13 cm for the CS₃ sampler. Move in a straight line between the numbers on the measuring tape. Angle over to the second strip on the next pass gradually, and repeat four double passes. After sampling

¹² A filter holder for circular 25-cm particle filters and flow control valve assembly which replaces the normal flow control assembly is available from the manufacturer of the floor vacuum device.

¹³ *Reagent Chemicals, American Chemical Society Specifications*, American Chemical Society, Washington, DC. For suggestions on the testing of reagents not listed by the American Chemical Society, see *Analar Standards for Laboratory Chemicals*, BDH Ltd., Poole, Dorset, U.K., and the *United States Pharmacopeia and National Formulary*, U.S. Pharmacopeial Convention, Inc. (USPC), Rockville, MD.