



Designation: D 5443 – 93 (Reapproved 1998)

## Standard Test Method for Paraffin, Naphthene, and Aromatic Hydrocarbon Type Analysis in Petroleum Distillates Through 200°C by Multi- Dimensional Gas Chromatography<sup>1</sup>

This standard is issued under the fixed designation D 5443; the number immediately following the designation indicates the year of original adoption or, in the case of revision, the year of last revision. A number in parentheses indicates the year of last reapproval. A superscript epsilon ( $\epsilon$ ) indicates an editorial change since the last revision or reapproval.

### 1. Scope

1.1 This test method provides for the determination of paraffins, naphthenes, and aromatics by carbon number in low olefinic hydrocarbon streams having final boiling points of 200°C or less. Hydrocarbons with boiling points greater than 200°C and less than 270°C are reported as a single group. Olefins, if present, are hydrogenated and the resultant saturates are included in the paraffin and naphthene distribution. Aromatics boiling at C<sub>9</sub> and above are reported as a single aromatic group.

1.2 This test method is not intended to determine individual components except for benzene and toluene that are the only C<sub>6</sub> and C<sub>7</sub> aromatics, respectively, and cyclopentane, that is the only C<sub>5</sub> naphthene. The lower limit of detection for a single hydrocarbon component or group is 0.05 mass %.

1.3 This test method is applicable to hydrocarbon mixtures including virgin, catalytically converted, thermally converted, alkylated and blended naphthas.

1.4 The values stated in SI (metric) units are to be regarded as the standard.

1.5 *This standard does not purport to address all of the safety concerns, if any, associated with its use. It is the responsibility of the user of this standard to establish appropriate safety and health practices and determine the applicability of regulatory limitations prior to use.* Specific precautionary statements are given in Note 1 and Note 2 and Table 1.

### 2. Referenced Documents

#### 2.1 ASTM Standards:

D 4057 Practice for Manual Sampling of Petroleum and Petroleum Products<sup>2</sup>

D 4307 Practice for Preparation of Liquid Blends for Use As Analytical Standards<sup>2</sup>

<sup>1</sup> This test method is under the jurisdiction of ASTM Committee D-2 on Petroleum Products and Lubricants and is the direct responsibility of Subcommittee D02.04.0L on Gas Chromatography.

Current edition approved Aug. 15, 1993. Published October 1993.

<sup>2</sup> Annual Book of ASTM Standards, Vol 05.02.

TABLE 1 Hydrocarbon Test Mixture

Hydrocarbons	Warning
Cyclopentane	(Warning—Extremely Flammable. Harmful if inhaled.)
Pentane	(Warning—Extremely Flammable. Harmful if inhaled.)
Cyclohexane	(Warning—Extremely Flammable. Harmful if inhaled.)
2,3-Dimethylbutane	(Warning—Extremely Flammable. Harmful if inhaled.)
Hexane	(Warning—Extremely Flammable. Harmful if inhaled.)
1-Hexene	(Warning—Extremely Flammable. Harmful if inhaled.)
Methylcyclohexane	(Warning—Extremely Flammable. Harmful if inhaled.)
4-Methyl-1-hexene	(Warning—Extremely Flammable. Harmful if inhaled.)
Heptane	(Warning—Flammable. Harmful if inhaled.)
1,cis-2-Dimethylcyclohexane	(Warning—Extremely Flammable. Harmful if inhaled.)
2,2,4-Trimethylpentane (iso-octane)	(Warning—Flammable. Harmful if inhaled.)
Octane	(Warning—Flammable. Harmful if inhaled.)
1,cis-2,cis-4-Trimethylcyclohexane	(Warning—Flammable. Harmful if inhaled.)
Nonane	(Warning—Flammable. Harmful if inhaled.)
Decane	(Warning—Flammable. Harmful if inhaled.)
Undecane	(Warning—Flammable. Harmful if inhaled.)
Dodecane	(Warning—Flammable. Harmful if inhaled.)
Benzene	(Warning—Extremely Flammable. Harmful if inhaled.)
Methylbenzene (Toluene)	(Warning—Flammable. Harmful if inhaled.)
trans-Decahydronaphthalene (Decalin)	(Warning—Flammable. Harmful if inhaled.)
Tetradecane	(Warning—Harmful if inhaled.)
Ethylbenzene	(Warning—Extremely Flammable. Harmful if inhaled.)
1,2-Dimethylbenzene (o-Xylene)	(Warning—Extremely Flammable. Harmful if inhaled.)
Propylbenzene	(Warning—Extremely Flammable. Harmful if inhaled.)
1,2,4-Trimethylbenzene	(Warning—Extremely Flammable. Harmful if inhaled.)
1,2,3-Trimethylbenzene	(Warning—Extremely Flammable. Harmful if inhaled.)
1,2,4,5-Tetramethylbenzene	(Warning—Flammable. Harmful if inhaled.)
Pentamethylbenzene	(Warning—Harmful if inhaled.)

### 3. Summary of Test Method

3.1 A representative sample is introduced into a gas chromatographic system containing a series of columns and switching valves. As the sample passes through a polar column, the polar aromatic compounds, bi-naphthenes, and high boiling (>200°C) paraffins and naphthenes are retained. The fraction not retained elutes to a platinum column, that hydrogenates olefins, if present, in this fraction, and then to a molecular sieve column which performs a carbon number separation based on molecular structure, that is, naphthenes and paraffins. The fraction remaining on the polar column is further divided into three separate fractions that are then separated on a non-polar

column by boiling point. Eluting compounds are detected by a flame ionization detector.

3.2 The mass concentration of each group is determined by the multiplication of detected peak areas by flame ionization detector response factors and normalization to 100 %.

#### 4. Significance and Use

4.1 A knowledge of the composition of hydrocarbon refinery streams is useful for process control and quality assurance.

4.2 Aromatics in gasoline are soon to be limited by federal mandate. This test method can be used to provide such information.

#### 5. Interferences

5.1 Chemicals of a non-hydrocarbon composition may elute within the hydrocarbon groups, depending on their polarity, boiling point, and molecular size. Included in this group are ethers (for example, methyl-tertiary butyl ether) and alcohols (for example, ethanol).

#### 6. Apparatus

6.1 *Chromatograph*—A gas chromatograph capable of isothermal operation at  $130 \pm 0.1^\circ\text{C}$ . The gas chromatograph must contain the following:

6.1.1 A heated flash vaporization sample inlet system capable of operation in a splitless mode.

6.1.2 Associated gas controls with adequate precision to provide reproducible flows and pressures.

6.1.3 A flame ionization detection system optimized for use with packed columns and capable of the following:

Isothermal temperature operation	150 to $170^\circ\text{C}$
Sensitivity	$>0.015$ coulombs/g
Minimum detectability	$5 \times 10^{-12}$ g carbon/second
Linearity	$>10^7$

Some instruments will produce a non-linear response for benzene, above approximately 5.5 mass %, and for toluene above approximately 15 mass %. The linearity of these components above these concentrations must be verified with appropriate blends. Where non-linearity has been shown to exist, samples, that contain no higher than  $C_{13}$ , can be analyzed if the sample is diluted with  $n-C_{15}$  and the instrument is equipped with a prefractionating column. The sample may also be diluted with a component that is not present in the sample and this component will then not be included in the normalized report.

6.2 *Sample Introduction System*—Manual or automatic liquid sample system operated in a splitless mode. Although this test method is intended primarily for use with syringe sample injection, automatic sampling valves have also been found satisfactory. Devices capable of a reproducible injection volume of 0.1 to 0.5  $\mu\text{L}$  are suitable. The sample introduction system must be capable of heating the sample to a temperature that ensures total sample vaporization. A temperature range of 120 to  $180^\circ\text{C}$  has been found suitable.

6.3 *Electronic Data Acquisition System*—The data acquisition and integration device used for detection and integration must meet or exceed the following specifications:

- 6.3.1 Capacity for at least 75 peaks for each analysis,
- 6.3.2 Normalized area percent calculation,
- 6.3.3 Noise and spike rejection capability,
- 6.3.4 Sampling rates for fast ( $<2$  s) peaks,
- 6.3.5 Peak width detection for narrow and broad peaks, and
- 6.3.6 Perpendicular drop and tangent skimming as required.

6.4 *Independent Temperature Control*—This test method requires the temperature control of five columns, column switching valves and sample lines. The columns consist of polar, non-polar, Tenax<sup>3</sup>, platinum, and molecular sieve columns. The specifications for these columns are listed in Table 2. The polar column, non-polar column, column switching valves, and sample lines require isothermal operation at a temperature equivalent to the temperature of the gas chromatograph oven. These components may be located in the gas chromatograph oven. The Tenax<sup>3</sup> column, platinum column, and molecular sieve column require operation at temperatures other than the gas chromatograph oven temperature. These columns may be temperature controlled by any means that will meet the following specifications:

6.4.1 Ability to control the temperature of the Tenax<sup>3</sup> column within a range from 60 to  $280^\circ\text{C}$ , with a tolerance of  $\pm 5^\circ\text{C}$  at any point. The time required to heat this column between any two points must be no more than 1 min. The time required to cool this column between any two points must be no more than 5 min,

6.4.2 Ability to control the temperature of the molecular sieve column within a range from 100 and  $490^\circ\text{C}$ , with a

<sup>3</sup> Tenax is a registered trademark of AKZO, Velperiveg 76, P.O. Box 9300, 6800 SB Arnhem, The Netherlands.

**TABLE 2 Typical Column Specifications**

Specification	Column Type				
	Polar	Non-Polar	Tenax <sup>3</sup>	Molsieve <sup>A</sup>	Platinum <sup>A</sup>
Column length, m	3	4	0.16 to 0.18	1.8	0.002 to 0.06
Column inside diameter, mm	2.0 to 2.1	1.8 to 2.0	2.5	1.6 to 2.0	1.6
Liquid phase	OV-275 <sup>B</sup>	OV-101 <sup>B</sup>	...	...	...
Percent liquid phase	30	4–5	...	...	...
Support material	Chromasorb <sup>C</sup> PAW	Chromasorb <sup>C</sup> WAW	...	...	...
Packing material	...	...	Tenax <sup>3</sup>	Molecular sieve 13X <sup>D,E</sup>	...
Mesh size	60/80	80/100	80/100	...	...


<sup>A</sup>Available from AC Analytical Controls, 3448 Progress Dr., Bensalem, PA 19020.

<sup>B</sup>OV- 101 and OV-275 are registered trademarks of Ohio Valley Specialty Chemical Co., 115 Industry Rd., Marietta, OH 45750.

<sup>C</sup>Chromasorb is a registered trademark of Manville Corp., Box 519, Lompoc, CA 93438.

<sup>D</sup>Sodium form of molecular sieve 13X.

<sup>E</sup>May also contain a mix of molecular sieves 13X and 5A to separate normal and iso-paraffins.

 **D 5443 – 93 (1998)**

tolerance of  $\pm 10^{\circ}\text{C}$  at any point. The time required to heat this column between any two points must be no more than 10 min. The time required to cool this column from 450 to  $100^{\circ}\text{C}$  must be no more than 15 min, and

6.4.3 Ability to control the platinum column within a temperature range of 170 and  $350^{\circ}\text{C}$ . During routine analysis, this column is operated within a temperature range of 170 to  $220^{\circ}\text{C}$ .

## 7. Materials

### 7.1 Carrier Gases:

7.1.1 Hydrogen, 99.999 % pure,  $<0.1$  ppm  $\text{H}_2\text{O}$ . (**Warning**—See Note 1.)

NOTE 1—**Warning:** Extremely flammable gas under high pressure.

7.1.2 Helium, 99.999 % pure,  $<0.1$  ppm  $\text{H}_2\text{O}$ . (**Warning**—See Note 2.)

NOTE 2—**Warning:** Compressed gas under high pressure.

### 7.2 Detector Gases:

7.2.1 Hydrogen, 99.99 % minimum purity. (**Warning**—See Note 1.)

7.2.2 Air, less than 10 ppm each of total hydrocarbons and water. (**Warning**—See Note 2.)

7.3 Valve Actuation Gas—This test method permits the use of any type of valve switching or valve actuation. When pneumatic valves are used, air of any grade that will result in no water condensation or will not introduce oil or other contaminants in the switching valves may be used. Air from a piston operated compressor equipped with a water and oil separator has been found suitable. Column switching valves that do not require air to operate do not have this air requirement.

7.4 Columns—Five columns, as described in Table 2. These column specifications are to be considered as guidelines and have been found to be acceptable. Other materials or combinations of materials may also provide acceptable performance. The suitability of each column is determined by test criteria as defined in Section 8.

NOTE 3—It is not the intention of this test method to include detailed column preparation steps. Columns may be prepared in any way that follows accepted safety practices and results in columns that will meet the performance requirements of Section 9.

7.5 Valves—This test method uses valves for column switching and flow switching. Any commercially available valves may be used that are intended for, or adapted for use in gas chromatography that meet the following specifications:

7.5.1 The column switching valves are generally installed in the gas chromatograph oven. These valves must be capable of continuous operation at the operating temperature of the GC oven.

7.5.2 Materials used in the construction of the valves must be unreactive to hydrocarbons present in the sample under analysis conditions. Stainless steel, PFA, and vespel materials have been found suitable.

7.5.3 Valves must be sized such that they offer little restriction to carrier gas flow under the analysis conditions defined in this test method.

7.5.4 Care must be taken to prevent the introduction of any form of foreign material or contaminant into the valve that may adversely affect its performance.

7.6 Hydrocarbon Test Mixture—A quantitative synthetic mixture of pure hydrocarbons, an example of which is identified in Table 1 is used to tune the instrument analysis conditions and establish that the instrument is performing within specifications. Individual hydrocarbon components, in addition to those listed in Table 1, may be used to aid in the analysis. The concentration level of each component in the hydrocarbon test mixture is not critical as long as the concentration is accurately known. Percentage ranges from 1.0 to 6.0 mass % have been found suitable. Impurities in the individual components may have an adverse effect on the quantitative aspect of the analysis. If an impurity is of the same carbon number and basic molecular structure as the main component itself, it will be correctly grouped and quantitated within the group. As an example, isobutylcyclopentane and isopropylcyclohexane will both be determined as  $\text{C}_9$  naphthenes. Each of the individual hydrocarbon components used for this test mixture must have a minimum purity level of 99 mol %. Refer to Practice D 4307 for instructions on the preparation of liquid blends for use as analytical standards.

### 7.7 Gas Flows and Pressures:

#### 7.7.1 Carrier Gases:

7.7.1.1 The helium carrier gas through the injection port, polar column, platinum column and molecular sieve column is flow controlled. Flow rates of 16 to 23 mL/min have been found suitable. A helium supply pressure of 620 kDa (90 psi) has been found suitable to meet the helium flow requirement. The helium carrier gas flow will be referred to as the A flow within this test method.

7.7.1.2 The helium carrier gas used as the make up gas when the polar column is in stop flow is set to the same flow rate as the helium carrier gas through the injection port.

7.7.1.3 The hydrogen carrier gas flow through the Tenax<sup>3</sup> column and non-polar column is flow controlled. Flow rates of 12 to 17 mL/min have been found suitable. A hydrogen supply pressure of 517 kDa (75 psi) has been found suitable to meet the hydrogen flow requirements. The hydrogen carrier gas flow will be referred to as the “B” flow within this test method.

7.7.1.4 The hydrogen flow to the platinum column is flow controlled. Flow rates of 10 to 15 mL/min have been found suitable.

7.7.2 Detector Gases—The flow rates of the air and hydrogen, as oxidant and fuel gases for the flame ionization detector, must be set according to the instrument manufacturer’s instructions.

7.7.3 Valve Actuation Gases—Pneumatic valves require air delivery at pressures and flows adequate to ensure correct actuation. When pneumatic valves are used for this test

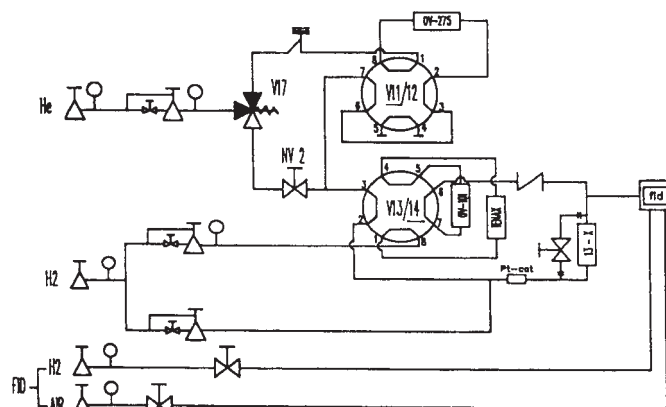
**ASTM D 5443 – 93 (1998)**

method, air pressure and flow must be provided in accordance with the valve manufacturer's instructions.

**8. System Description**

8.1 Commercial instruments are available that meet the specifications of this test method. One such system<sup>4</sup> is based on pneumatic valves. Another system<sup>5</sup> is based on rotary valves. Additional operating instructions are included in the operating and maintenance manuals for these instruments. The figures in this test method are applicable to these systems.

8.1.1 Fig. 1 and Fig. 2 illustrate typical instrument configurations that use different column valve switching techniques. This test method allows use of either configuration.

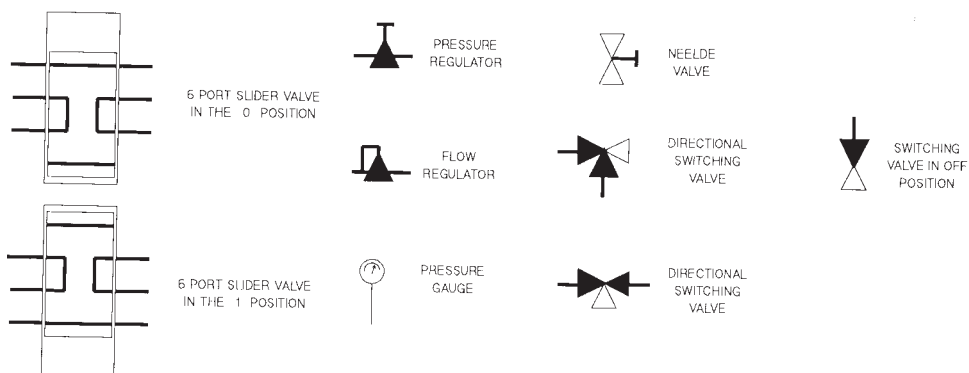
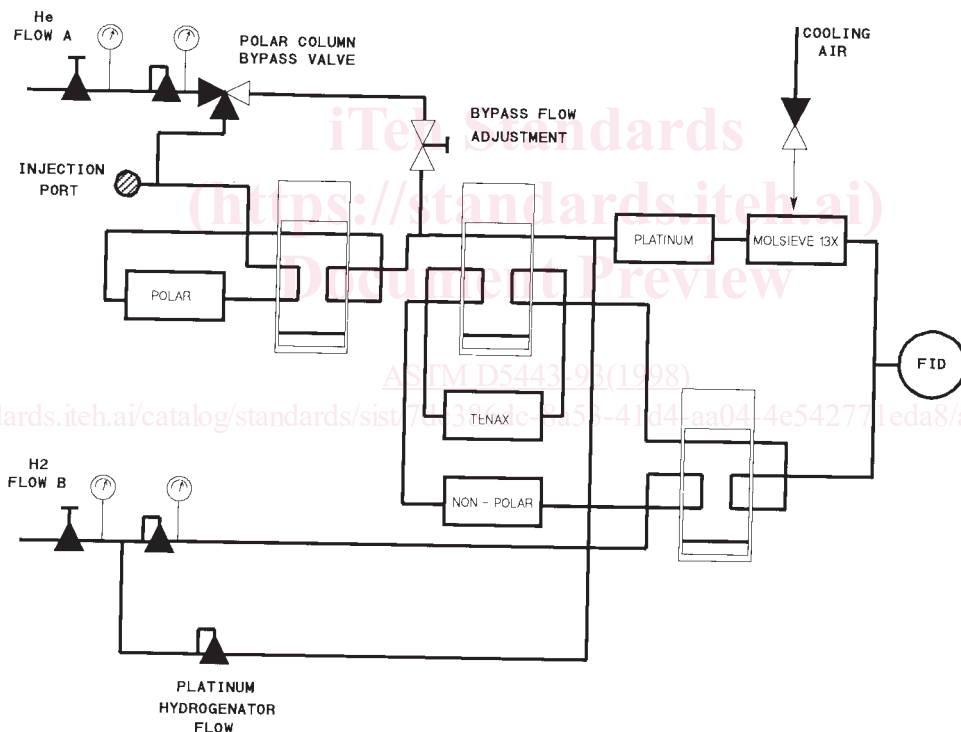


**FIG. 2 Typical Instrument Configuration with Rotary Valves**

<sup>4</sup> Instrument commercially available from AC Analytical Controls, 3448 Progress Drive, Bensalem, PA 19020.

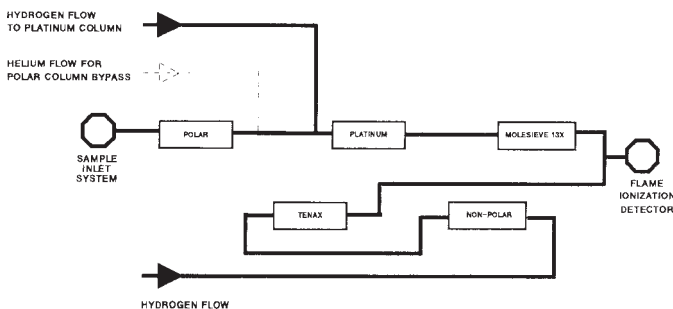
<sup>5</sup> Instrument commercially available from Chrompack, International BV 4330 EA Middleburg, The Netherlands.

8.1.2 Figs. 3-13 illustrate the system flow configurations during the column test and sample analysis phases of this test method.

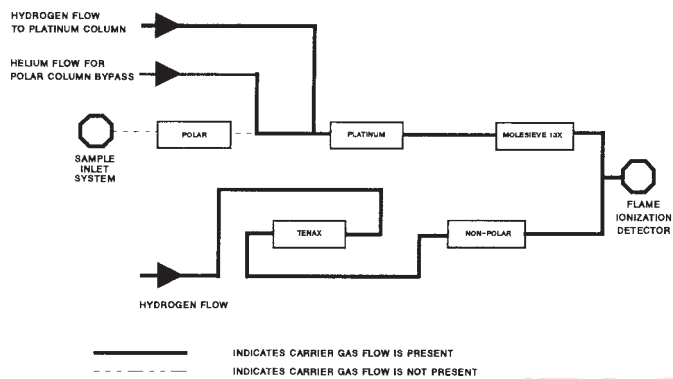


**FIG. 1 Typical Instrument With Six Port Slider Valves**

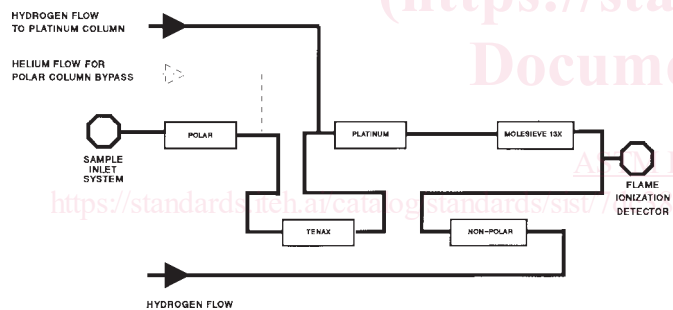
**D 5443 – 93 (1998)**



**FIG. 3 Start of the "A" Time**



NOTE 1—Polar column is placed in stop flow.  
**FIG. 4 End of the "A" Time**

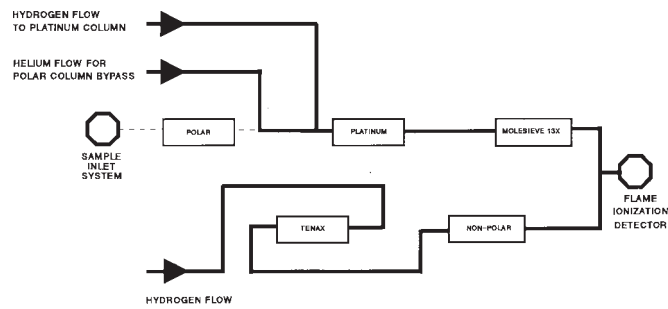


NOTE 1—First aromatic elution from the polar column.  
**FIG. 5 Start of the "B" Time**

8.1.3 Table 3 and Table 4 list the conditions that apply during the column test and sample analysis phases for the instrument configuration in Fig. 1.

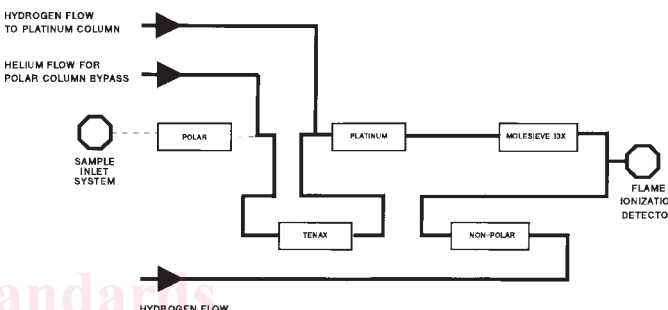
8.1.4 Table 5 and Table 6 list the conditions that apply during the column test and sample analysis phases for the instrument configuration in Fig. 2.

8.2 The polar column separates the sample into four fractions. The first three fractions are fore-flushed through the polar column and the last is back-flushed. Upon completion of each elution cycle, the flow through the column is stopped to maintain the relative position of non-eluted components within the column. For the purpose of simplicity, the three fore-flushes of the polar column will be called the "A," "B," and "C" cuts respectively. The length of time associated with each cut will be called the "A," "B," and "C" times respectively. These times

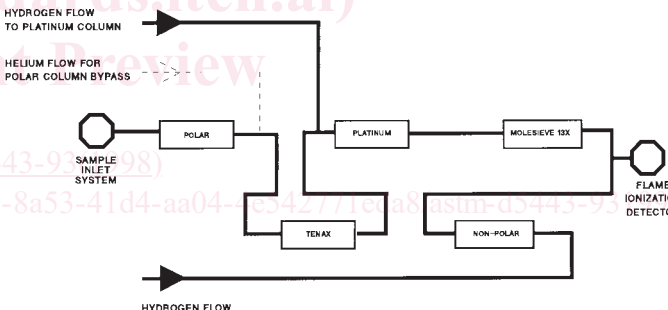


— INDICATES CARRIER GAS FLOW IS PRESENT  
- - - INDICATES CARRIER GAS FLOW IS NOT PRESENT

NOTE 1—Begin first aromatic elution to the detector.  
**FIG. 6 End of the "B" Time**



**FIG. 7 Non-Polar Column Back Flush to the Detector**



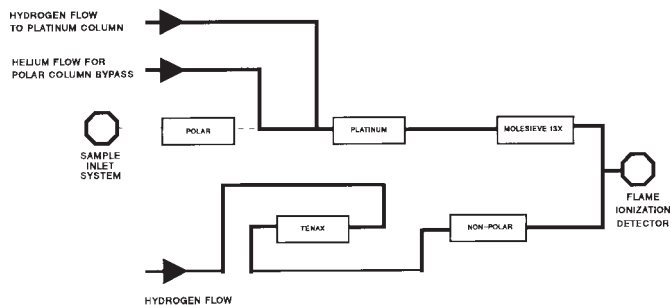
— INDICATES CARRIER GAS FLOW IS PRESENT  
- - - INDICATES CARRIER GAS FLOW IS NOT PRESENT

NOTE 1—Second aromatic cut elution from the polar column.  
**FIG. 8 Start of the "C" Time**

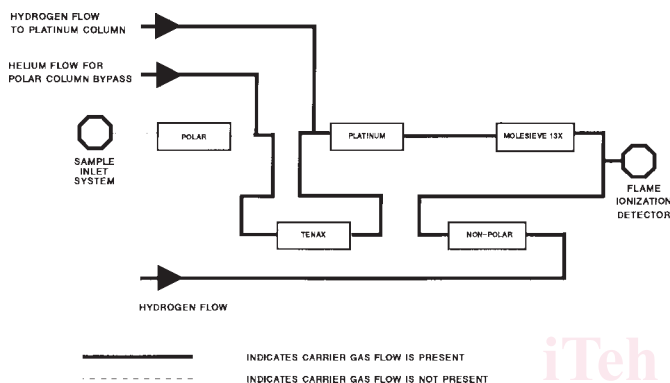
are independent of each other and are a function of instrument configuration, column performance and carrier gas flow conditions.

**9. Preparation of Apparatus**

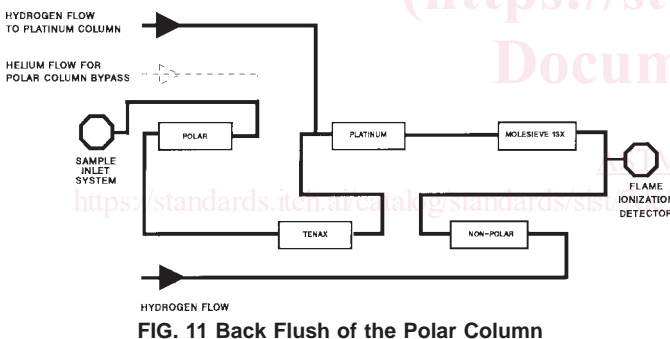
9.1 Place the gas chromatograph in service in accordance with the manufacturer's instructions. The initial settings listed in Table 3 and Table 4 have been found suitable for slider valve type instruments. The initial settings listed in Table 5 and Table 6 have been found suitable for rotary valve type instruments. Variances in column to column performance require that each flow setting and cut time be determined experimentally.



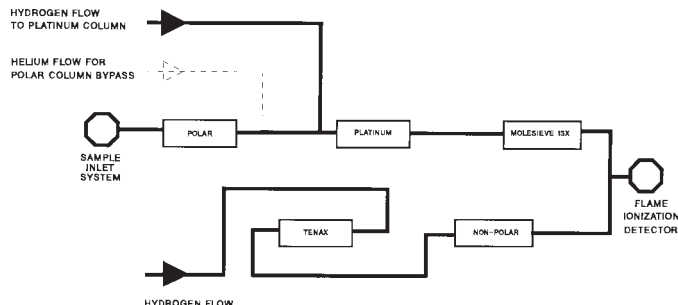
NOTE 1—Begin second aromatic elution to the detector.  
**FIG. 9 End of the "C" Time**



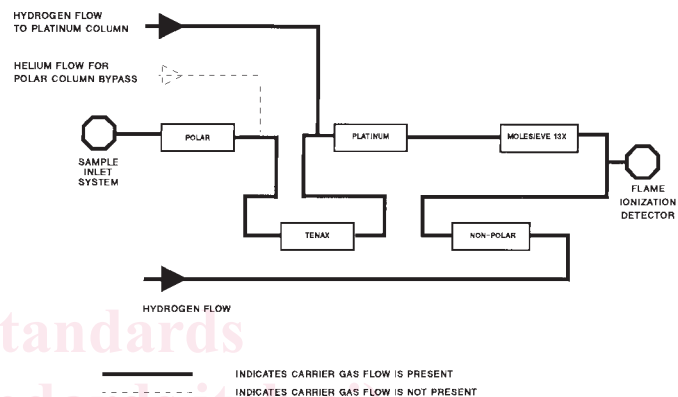
**FIG. 10 Non-Polar Column Back Flush to the Detector**



**FIG. 11 Back Flush of the Polar Column**



**FIG. 12 Final Elution to the Non-Polar Column**



**FIG. 13 Back Flush of the Non-Polar Column to the Detector**

**TABLE 3 Temperature Settings, For Slider Valve Instruments (see Fig. 1)**

Device	Initial Temperature, (°C)	Final Temperature, (°C)	Rate, (minutes)
Polar column	130	130	isothermal
Non-polar column	130	130	isothermal
Platinum column	220	220	isothermal
Detector	150	150	isothermal
Molecular sieve 13X	100	430, minimum	30 ± 5, logarithmic
Tenax <sup>3</sup> column	60	280	1, maximum

**TABLE 4 Flow Settings and Cut Times, For Slider Valve Instruments (see Fig. 1)**

Description	Initial Setting, minutes	Acceptable Range, minutes
Helium flow through injection port	20 mL/min	16 to 23 mL/min
Helium polar column bypass flow	same flow rate as injection port	same flow rate as injection port
Hydrogen flow to platinum column	12 mL/min	10 to 15 mL/min
Hydrogen flow through non-polar column	14 mL/min	12 to 17 mL/min
A time	3.6	2.7 to 4.6
B time	3.4	2.7 to 4.6
C time	3.6	2.7 to 4.6

9.2 The carrier gas flow rates, A, B, and C times must be adjusted to produce acceptable analytical performance with the hydrocarbon test mixture in 7.6. These conditions are then recorded and must be used for sample analysis. The system is considered to meet the test method specifications if the hydrocarbon test mixture analysis absolute errors, as calculated in Sections 11 and 12, are equal to or less than the following: ±0.3 % per carbon number per hydrocarbon type (for example, C<sub>5</sub> paraffins), and ±0.3 % per hydrocarbon class (for example, all paraffins).

**9.3 Tuning Instrument Conditions with Hydrocarbon Test Mixture:**

9.3.1 Configure the system initially as illustrated in Fig. 3. Use the conditions in Table 3 and Table 4 for slider valve type instruments or Table 5 and Table 6 for rotary valve type instruments.

9.3.2 Inject approximately 0.2 µL of the hydrocarbon test mixture and begin recording the signal from the detector. The

sample injection marks the beginning of the A time. Allow paraffins and naphthenes with boiling points below 200°C to elute from the polar column. Retain aromatics, polynaphthenes, if present, and components boiling above 200°C on the polar column during the A time. If olefins are present in