



SLOVENSKI STANDARD
SIST ISO 1875:1996

01-junij-1996

Polimerni materiali - Mehčani acetat celuloze - Določanje izlužljivega z dietiletrom

Plastics -- Plasticized cellulose acetate -- Determination of matter extractable by diethyl ether

Plastiques -- Acétate de cellulose plastifié -- Détermination des matières extractibles par l'oxyde diéthylique

ITeh STANDARD PREVIEW
(standards.iteh.ai)

Ta slovenski standard je istoveten z: ISO 1875:1982

SIST ISO 1875:1996
<https://standards.iteh.ai/catalog/standards/sist/21db0304-8da1-4d9e-b3cb-97442f2bed/sist-iso-1875-1996>

ICS:

83.080.20 Plastomeri

Thermoplastic materials

SIST ISO 1875:1996

en

iTeh STANDARD PREVIEW
(standards.iteh.ai)

SIST ISO 1875:1996

<https://standards.iteh.ai/catalog/standards/sist/21db0304-8da1-4d9e-b3cb-97442f5f2bed/sist-iso-1875-1996>

International Standard



1875

INTERNATIONAL ORGANIZATION FOR STANDARDIZATION • МЕЖДУНАРОДНАЯ ОРГАНИЗАЦИЯ ПО СТАНДАРТИЗАЦИИ • ORGANISATION INTERNATIONALE DE NORMALISATION

Plastics — Plasticized cellulose acetate — Determination of matter extractable by diethyl ether

Plastiques — Acétate de cellulose plastifié — Détermination des matières extractibles par l'oxyde diéthylique

First edition — 1982-02-15

iTeh STANDARD PREVIEW
(standards.iteh.ai)

[SIST ISO 1875:1996](#)

<https://standards.iteh.ai/catalog/standards/sist/21db0304-8da1-4d9e-b3cb-97442f52bed/sist-iso-1875-1996>

UDC 678.544

Ref. No. ISO 1875-1982 (E)

Descriptors : plastics, plastified cellulose acetate, tests, determination, soluble matter, ethyl ether.

Foreword

ISO (the International Organization for Standardization) is a worldwide federation of national standards institutes (ISO member bodies). The work of developing International Standards is carried out through ISO technical committees. Every member body interested in a subject for which a technical committee has been set up has the right to be represented on that committee. International organizations, governmental and non-governmental, in liaison with ISO, also take part in the work.

Draft International Standards adopted by the technical committees are circulated to the member bodies for approval before their acceptance as International Standards by the ISO Council.

International Standard ISO 1875 was developed by Technical Committee ISO/TC 61, *Plastics*.

It was submitted directly to the ISO Council, in accordance with clause 5.10.1 of part 1 of the Directives for the technical work of ISO. It cancels and replaces ISO Recommendation R 1875-1971, which had been approved by the member bodies of the following countries :

Austria	Greece	Spain
Belgium	Hungary	Sweden
Canada	Italy	Switzerland
Chile	Netherlands	Turkey
Czechoslovakia	New Zealand	United Kingdom
Egypt, Arab Rep. of	Poland	USA
France	Romania	USSR
Germany, F. R.	South Africa, Rep. of	

No member body had expressed disapproval of the document.

Plastics — Plasticized cellulose acetate — Determination of matter extractable by diethyl ether

1 Scope and field of application

This International Standard specifies a method for the determination of the percentage of matter which can be extracted by diethyl ether from plasticized cellulose acetate.

The method applies to plasticized cellulose acetate in any form, such as moulding material, sheet, manufactured articles, etc.

NOTE — The extractable matter comprises principally the plasticizer.

2 Principle

Conversion of plasticized cellulose acetate to film by dissolving and casting, then extraction by diethyl ether in a Soxhlet apparatus. Removal of the ether by heating under vacuum, then weighing of the residual matter.

3 Reagents

During the analysis use only reagents of recognized analytical grade.

3.1 Dichloromethane, with relative density (20 °C/20 °C) from 1,321 to 1,331, and not less than 95 % (V/V) distilling between 39 and 40,5 °C under a pressure of 101,3 kPa*.

3.2 Methanol, with relative density (20 °C/20 °C) from 0,792 to 0,795 and distillation range from 64,5 to 65,5 °C under a pressure of 101,3 kPa*.

3.3 Diethyl ether, free from peroxides, with relative density (20 °C/20 °C) from 0,714 to 0,716, and distillation range from 34 to 35 °C under a pressure of 101,3 kPa*.

The residue on evaporation should be less than 1,5 mg per 100 ml.

4 Apparatus

Ordinary laboratory apparatus and

4.1 Clear glass bottle, of capacity 150 ml, tightly stoppered.

4.2 Flat rectangular glass sheet, 4 mm in thickness and about 200 mm × 400 mm.

4.3 Film casting device to lay a cast film of about 0,1 mm thickness. A suitable type of device is shown in the figure.

4.4 Soxhlet extraction apparatus, comprising the following items :

4.4.1 Extraction flask, of capacity 250 ml.

4.4.2 Condenser.

4.5 Thimble for Soxhlet extractor.

4.6 Thermostatic oven, capable of being maintained at 50 ± 2 °C and at 105 ± 2 °C.

4.7 Vacuum thermostatic oven, capable of being maintained at 50 ± 2 °C.

4.8 Desiccator, containing dry silica gel.

4.9 Balance, accurate to 0,001 g.

4.10 Shaking device to hold the glass bottle (4.1).

5 Preparation of test sample

5.1 Prepare a mixture of 90 parts of dichloromethane (3.1) and 10 parts of methanol (3.2) by volume, at room temperature.

5.2 Weigh $10 \pm 0,2$ g of plasticized cellulose acetate and introduce it into the glass bottle (4.1). Add 100 ± 2 ml of dichloromethane-methanol mixture (5.1), and put the stoppered glass bottle on the shaker (4.10) and shake until complete solution.

5.3 Using the film casting device (4.3), spread a layer of the solution on the glass sheet, so that after complete evaporation of the solvent at room temperature, a film of approximately 0,1 mm thickness is obtained.

* 101,3 kPa = 1 013 mbar = 760 mmHg.

ISO 1875-1982 (E)

5.4 Remove the film and cut it in strips about 5 mm wide, and of length suitable for the extraction thimble (4.5).

6 Procedure A

6.1 Weigh the thimble (4.5), previously extracted by ether (3.3) and dried at 105 ± 2 °C, to the nearest 0,001 g, in a dried weighing bottle.

6.2 Place in the thimble about 2 g of freshly prepared test sample.

6.3 Weigh the extraction flask (4.4.1), previously dried at 50 ± 2 °C, to the nearest 0,001 g and fill with about 200 ml of ether (3.3).

6.4 Connect the extraction flask to the Soxhlet extractor (4.4), and this to the condenser (4.4.2). Extract for about 3 h on a water bath.

6.5 Disconnect the extraction flask and evaporate most of the ether by using a water aspirator. Place in the vacuum thermostatic oven (4.7), maintained at 50 ± 2 °C, for 2 h for complete removal of the solvent. Allow the extraction flask to cool in the desiccator (4.8) and weigh to the nearest 0,001 g.

6.6 Pull out the thimble from the Soxhlet extractor and allow most of the solvent to evaporate at room temperature. Place in the vacuum thermostatic oven (4.7), maintained at 50 ± 2 °C, for 30 min and then in the thermostatic oven (4.6), maintained at 105 ± 2 °C, for 3 h.

6.7 Allow the thimble to cool in the desiccator and weigh, to the nearest 0,001 g, using a dried weighing bottle.

7 Procedure B

7.1 Dry a suitable quantity of the freshly prepared test sample at 105 ± 2 °C for 1 h.

7.2 Weigh the thimble (4.5), previously extracted by ether (3.3) and dried at 105 ± 2 °C, to the nearest 0,001 g in a dried weighing bottle.

7.3 Place in the thimble about 2 g of the freshly dried test sample and immediately reweigh to the nearest 0,001 g, in a dried weighing bottle.

7.4 Proceed according to 6.3, 6.4 and 6.5.

8 Expression of results

The diethyl ether extractable matter content, expressed as a percentage by mass, is given by one of the following formulae :

a) If procedure A is used

$$\frac{m_1}{m_1 + m_2} \times 100$$

where

m_1 is the mass, in grams, of the residue in the extraction flask;

m_2 is the mass, in grams, of the test portion remaining in the thimble after extraction.

b) If procedure B is used

$$\frac{m_1}{m_3} \times 100$$

where

m_1 has the same meaning as in a);

m_3 is the mass, in grams, of the test sample determined in accordance with 7.3.

Take as the result the arithmetic mean of the values obtained by two determinations.

9 Test Report

The test report shall include the following particulars :

- reference to this International Standard;
- complete identification of product tested, including type, manufacturer's code number, source, trade name, etc.
- percentage of diethyl ether extractable matter;
- the procedure used (A or B).

Dimensions in millimetres

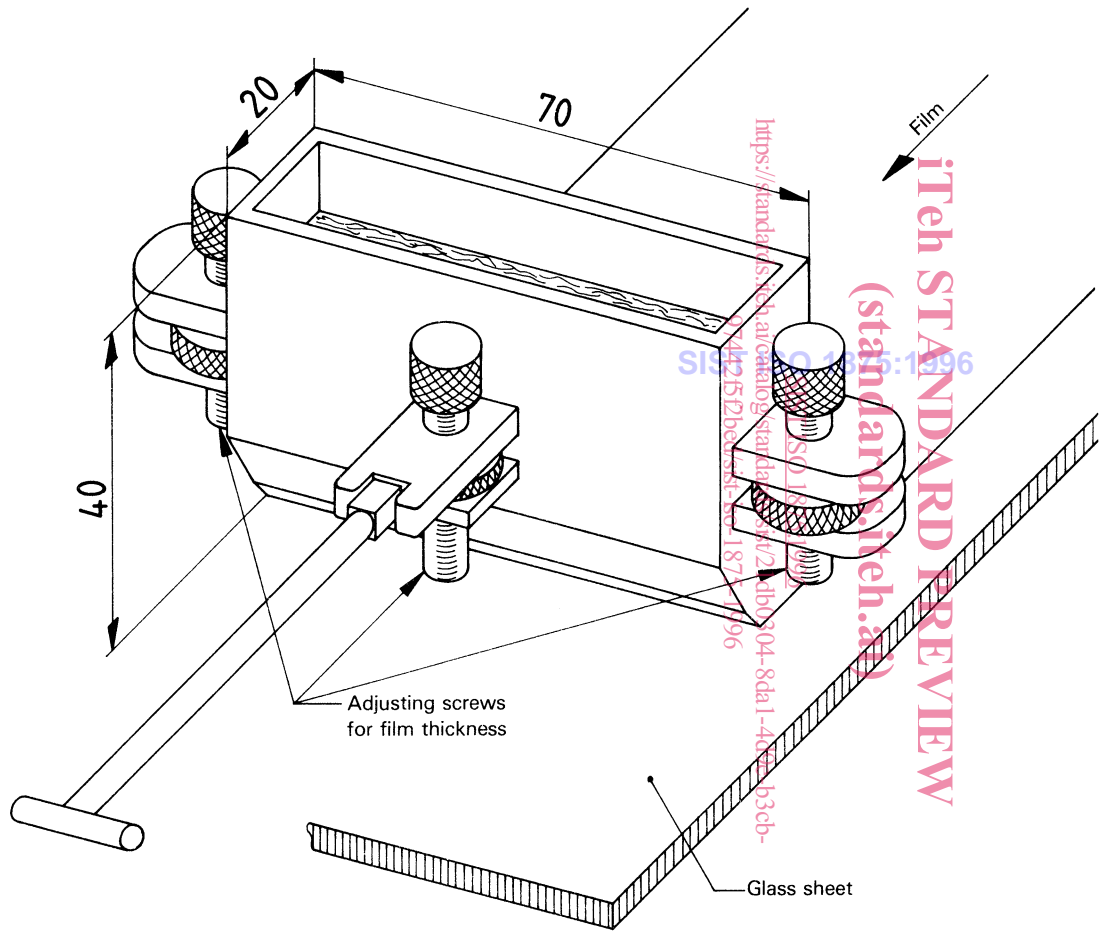

Figure — Suitable type of film casting device