



Designation: ~~E1556-03~~ Designation: E 1556 – 08

## Standard Specification for Epoxy Resin System for Composite Skin, Honeycomb Sandwich Panel Repair<sup>1</sup>

This standard is issued under the fixed designation E 1556; the number immediately following the designation indicates the year of original adoption or, in the case of revision, the year of last revision. A number in parentheses indicates the year of last reapproval. A superscript epsilon ( $\epsilon$ ) indicates an editorial change since the last revision or reapproval.

*This standard has been approved for use by agencies of the Department of Defense.*

### 1. Scope

1.1 This specification covers the requirements for an epoxy resin system intended for the repair of sandwich panels for durable, rigidwall, relocatable structures. It must be usable in a field environment and shall not require the use of special equipment such as autoclaves or presses. The epoxy system covered by this specification shall be usable for simultaneous impregnation of a wet-layup composite skin and bonding of that skin to a substrate honeycomb core. The material shall withstand exposure to temperatures from  $-54$  to  $93^{\circ}\text{C}$  ( $-65$  to  $199^{\circ}\text{F}$ ) and high relative humidity, and also the combination of stress, temperature, and relative humidity that are expected to be encountered in service.

1.2 The values stated in SI units are to be regarded as standard where only SI units are given or where SI units are given first followed by inch-pound units; where inch-pound units are given first followed by SI units, the inch-pound units are to be regarded as the standard.

1.3 The following safety hazards caveat refers only to the test methods described in this specification. *This standard does not purport to address all of the safety concerns, if any, associated with its use. It is the responsibility of the user of this standard to establish appropriate safety and health practices and determine the applicability of regulatory limitations prior to use.*

### 2. Referenced Documents

#### 2.1 *ASTM Standards:*<sup>2</sup>

C297 297/C 297M Test Method for Flatwise Tensile Strength of Sandwich Constructions  
D 792 Test Methods for Density and Specific Gravity (Relative Density) of Plastics by Displacement  
~~D2344 Test Method for Strength of Polymer Matrix Composite Materials by Short-Beam Method~~ 2344/D 2344M Test Method  
for Short-Beam Strength of Polymer Matrix Composite Materials and Their Laminates  
D 2584 Test Method for Ignition Loss of Cured Reinforced Resins  
D 2734 Test Methods for Void Content of Reinforced Plastics 56-08  
E 874 Practice for Adhesive Bonding of Aluminum Facings to Nonmetallic Honeycomb Core for Shelter Panels 6-08  
D 3165 Test Method for Strength Properties of Adhesives in Shear by Tension Loading of Single-Lap-Joint Laminated Assemblies

~~E874 Practice for Adhesive Bonding of Aluminum Facings to Nonmetallic Honeycomb Core for Shelter Panels~~  
E 1091 Specification for Nonmetallic Honeycomb Core for Use in Shelter Panels

#### 2.2 *Military Specifications:*<sup>3</sup>

MIL-I-24768 Insulation, Plastic, Laminated, Thermosetting, Glass-Cloth, Epoxy-Resin

#### 2.3 ~~Military Standards:~~ *Military Standards:*<sup>3</sup>

MIL-STD-129 Military Marking for Shipping and Storage  
MIL-STD-1916 DOD Preferred Methods for Acceptance of Product

#### 2.4 ~~Commercial Standards:~~ *Commercial Standards:*<sup>4</sup>

SAE-AMS-C-9084 Cloth, Glass, Finished for Epoxy Resin Laminates

<sup>1</sup> This specification is under the jurisdiction of ASTM Committee E06 on Performance of Buildings and is the direct responsibility of Subcommittee E06.53 on Materials and Processes for Durable Rigidwall Relocatable Structures.

Current edition approved Oct. 1, 2003. Published October 2003. Originally approved in 1993. Last previous edition approved in 1998 as E1556-98.

Current edition approved Nov. 1, 2008. Published December 2008. Originally approved in 1993. Last previous edition approved in 2003 as E 1556 – 03.

<sup>2</sup> Available from Standardization Documents Order Desk, Bldg. 4 Section D, 700 Robbins Ave., Philadelphia, PA 19111-5094, Attn: NPODS.

<sup>3</sup> For referenced ASTM standards, visit the ASTM website, [www.astm.org](http://www.astm.org), or contact ASTM Customer Service at [service@astm.org](mailto:service@astm.org). For *Annual Book of ASTM Standards* volume information, refer to the standard's Document Summary page on the ASTM website.

<sup>4</sup> Available from Society of Automotive Engineers (SAE), 400 Commonwealth Dr., Warrendale, PA 15096-0001.

<sup>5</sup> Available from Standardization Documents Order Desk, DODSSP, Bldg. 4, Section D, 700 Robbins Ave., Philadelphia, PA 19111-5098, <http://www.dodssp.daps.mil>.

<sup>6</sup> Normal failure modes are debonding along the core-skin interface or core tearing but other failure modes may be encountered.

### 3. Physical Requirements

#### 3.1 Working Characteristics:

3.1.1 *Application*—The components of the epoxy resin shall be readily hand-mixed to a smooth consistency suitable for application. It shall be uniform and free of lumps. The resin components, once mixed, shall not settle out. The epoxy material shall be suitable for the wet-layup impregnation of SAE-AMS-C-9084 glass cloth and for application to core materials over the temperature range of 16 to 38°C (60 to 100°F) and at relative humidities of 30 to 75 %.

3.1.2 *Application Life*—The application life of a 200-g kit of the mixed epoxy system shall be at least 60 min when tested in accordance with 3.1.5. The epoxy shall be considered to have reached the end of its application life when the viscosity of this 200-g quantity of mixed adhesive exceeds 20 000 centipoise.

3.1.3 *Curing*—The epoxy system shall be capable of curing at  $23 \pm 2^\circ\text{C}$  ( $73 \pm 4^\circ\text{F}$ ) in 7 days, or for no longer than 3 h at a temperature of 60 to 66°C (140 to 151°F), with a curing pressure not to exceed 14 psig. In a  $23^\circ \pm 3^\circ\text{C}$  cure, the curing pressure is not required to be maintained after the first 24 h. In a  $23 \pm 2^\circ\text{C}$  cure, the epoxy material shall develop the property levels listed in Table 1 within the first 24 h of cure (see 7.3.5). In order to meet the requirements of this specification, the property levels listed in Tables 2-4 must be achieved with the 7-day cure at  $23 \pm 2^\circ\text{C}$  ( $73 \pm 4^\circ\text{F}$ ).

3.1.4 *Storage Life*—The storage life period of the two parts of the epoxy resin system, when stored in airtight containers at 23°C (73°F), shall be at least 12 months from the date of shipment when tested in accordance with 7.3.5.

3.1.5 *Viscosity*—The viscosity of a 200-g kit of the mixed resin system shall be determined at  $23 \pm 2^\circ\text{C}$  ( $73 \pm 4^\circ\text{F}$ ) using a Brookfield viscometer with a No. 3 spindle at 20 rpm. A viscosity curve shall be determined by taking a reading immediately after mixing, and every 5 min thereafter until the viscosity exceeds 20 000 centipoise. The viscosity immediately after mixing shall not exceed 14 000 centipoise.

3.2 *Mechanical Properties*—Mechanical properties of test specimens prepared and tested as specified in Section 7 shall meet the respective requirements listed in Tables 2-4.

3.3 *Instruction Sheet*—The manufacturer shall provide a dated, coded, and titled instruction sheet outlining instructions for use of the epoxy system in impregnating and bonding SAE-AMS-C-9084 glass composite skins to honeycomb cores (Specification E 1091, Types I or II). These instructions shall be supplied by the manufacturer with the test report when requesting qualification (see 6.3) and also with each shipment of epoxy material (see 9.2). The following information shall be included:

3.3.1 All of the information listed in 5.3.1-5.3.11.

3.3.2 The application life of the mixed epoxy system at  $23 \pm 2^\circ\text{C}$  ( $73 \pm 4^\circ\text{F}$ ) and  $38 \pm 2^\circ\text{C}$  ( $100 \pm 4^\circ\text{F}$ ).

3.3.3 Mixing instructions shall be stated in detail for the epoxy resin system in the particular container supplied.

3.3.4 Application, impregnating, and curing instructions, including the spreading method, thickness range, and temperature/relative humidity working limitations.

3.3.5 Material Safety Data Sheets and necessary safety precautions to be observed throughout all operations.

3.3.6 Any other pertinent information relative to the use and storage of the two-part system (resin and curing agent) package (see 9.2).

### 4. Significance and Use

4.1 Epoxy resin systems used in the repair of composite skin sandwich panels for durable, rigidwall, relocatable shelters must have a combination of mechanical property levels and environmental resistance that will assure long-term durability of the skins and the skin-to-core adhesive bonds when exposed to severe climatic exposures. In addition, these epoxy materials must have processability characteristics that permit their use in a variety of repair scenarios and environments.

4.2 *Intended Use*—Epoxy systems conforming to this specification are intended for use in the repair of honeycomb panels at the maintenance field level. The material is intended for use with SAE-AMS-C-9084 glass cloth.

4.2.1 This is a procurement control document for the procurement of the epoxy system and designers shall be aware that the test values specified herein are based upon tests performed with specific glass-resin composite adherends and shall not be used for design data.

4.2.2 Epoxy systems covered by this specification are not intended for use in production bonding of sandwich construction.

### 5. Material and Ordering Information

5.1 *General Description*—The material shall be a two-part thermosetting epoxy system containing no asbestos, which shall not

<sup>4</sup> Available from Society of Automotive Engineers (SAE), 400 Commonwealth Dr., Warrendale, PA 15096-0001, <http://www.sae.org>.

**TABLE 1 Property Requirements for 24-h, 23°C Cure**

Property	Test Condition	Number of Specimens	Average Must Exceed		Minimum Must Exceed, <sup>A</sup>	
			MPa	(psi)	MPa	(psi)
Tensile Lap Shear Strength in accordance with 7.2.1, 7.3.1	23°C (73°F), dry	5	6.9	(1000)	5.85	(850)
Apparent Horizontal Shear Strength in accordance with 7.2.2, 7.3.2	23°C (73°F), dry	5	15.5	(2250)	13.15	(1910)

<sup>A</sup> All specimens tested must exceed these minimum values.

**TABLE 2 Tensile Lap Shear Strength Requirements (See 7.3.1)**

Test Condition	Number of Specimens	Average Must Exceed		Minimum Must Exceed, <sup>A</sup>	
		MPa	(psi)	MPa	(psi)
–40°C (–40°F), dry	5	13.8	(2000)	11.7	(1700)
23°C (73°F), dry	5	13.8	(2000)	11.7	(1700)
93°C (200°F), wet <sup>B</sup>	5	6.9	(1000)	5.9	(850)

<sup>A</sup> All specimens tested must exceed these minimum values.

<sup>B</sup> Wet = tested immediately after 30 days' exposure to 60°C (140°F) and 95 to 100 % R.H.

**TABLE 3 Apparent Horizontal Shear Strength Requirements**

Test Condition	Number of Specimens	Average Must Exceed		Minimum Must Exceed, <sup>A</sup>	
		MPa	(psi)	MPa	(psi)
23°C (73°F), dry	5	31.0	(4500)	26.3	(3820)
93°C (200°F), wet <sup>B</sup>	5	13.8	(2000)	11.7	(1700)

<sup>A</sup> All specimens tested must exceed these minimum values.

<sup>B</sup> Wet = tested immediately after 30 days exposure to 60°C (140°F) and 95 to 100 % R.H.

**TABLE 4 Flatwise Tensile Strength Requirements**

Test Condition	Number of Specimens	Average Must Exceed		Minimum Must Exceed, <sup>A</sup>	
		MPa	(psi)	MPa	(psi)
–40°C (–40°F), dry	5	2.8	(406)	2.4	(345)
23°C (73°F), dry	5	2.8	(406)	2.4	(345)
80°C (176°F), wet <sup>B</sup>	5	1.38	(200)	1.17	(170)

<sup>A</sup> All specimens tested must exceed these minimum values.

<sup>B</sup> Wet = tested immediately after 30 days exposure to 60°C (140°F) and 95 to 100 % R.H.

have a deleterious effect on the components being impregnated and bonded. It shall have physical characteristics that meet the requirements of Sections 3 and 6.

5.1.1 *Formulation Changes*—The epoxy material shall be approved only for the formulation that has passed the qualification tests and shall be used by the fabricator as approved. Any changes by the manufacturer, such as the adding or changing of pigments, hardeners, or fillers, or changes in the type or method of manufacture, changes in formulation of the basic resin, or any other changes, shall be cause for designating the adhesive as a new product that shall not be considered approved. The changed epoxy resin system shall be given a new code number and shall be resubmitted for approval under this specification. A new instruction sheet for this reformulated material shall be submitted by the manufacturer to the qualifying activity for approval (see 3.3 and section 10.3.2.3) and 10.3.2.3).

5.1.2 *Identification of Product*—The manufacturer shall identify each epoxy resin system submitted under this specification according to the type of container furnished for it (see Section 9). In addition, the manufacturer shall designate each epoxy system by a trade name and code number that shall be used to identify it. -7b0-4bdf-812d-a1c3607b9abc/astm-e1556-08

5.2 *Qualification*—In the case of epoxy systems for which the purchaser requires qualification, the procurement document shall state that awards will be made only for epoxy systems that are, at the time set for opening for bids, qualified, according to the requirements in Section 3, for inclusion on the applicable qualified products list. —In the case of epoxy systems for which the purchaser requires qualification, comprehensive testing in accordance with Section 7 shall be performed and documented in a test report.

5.3 *Procurement Documents*—Procurement documents shall specify the following:

- 5.3.1 Title, number, and date of this specification,
- 5.3.2 Epoxy resin system type and manufacturer's trade name,
- 5.3.3 Date of manufacture,
- 5.3.4 Manufacturer's name and address,
- 5.3.5 Manufacturer's batch/lot designation,
- 5.3.6 Contract number,
- 5.3.7 Date of shipment,
- 5.3.8 Expiration dates when stored at 23 ± 2°C (73 ± 4°F),
- 5.3.9 Manufacturer's recommended storage temperature,
- 5.3.10 Quantity required, and
- 5.3.11 Manufacturer's certification that the batch and lot meet the requirements of this specification.

## 6. Quality Assurance Provisions

6.1 *Responsibility for Inspection*—Unless otherwise specified in the contract or purchase order, the supplier is responsible for the performance of all inspection requirements as specified herein. Except as otherwise specified in the contract or purchase order, the supplier is permitted to use any facility suitable for the performance of the inspection requirements specified herein, unless disapproved by purchaser. The purchaser reserves the right to perform any of the inspections set forth in the specification where such inspections are required to ensure that supplies and services conform to prescribed requirements.

6.2 *Classification of Tests*—The inspection and testing of the epoxy system shall be classified as qualification tests (see 6.3) and quality conformance tests (see 6.4).

6.3 *Qualification Tests:*

6.3.1 *Sampling Instruction:*

6.3.1.1 *Epoxy Resin System Samples*—The manufacturer shall submit two 1-qt samples of the base epoxy resin, along with the necessary curing agent, from a single-numbered production batch of material being presented for qualification. The manufacturer shall submit two additional 200-g kits of the two-part system (resin and curing agent) from the same production batch for storage life tests (7.3.4). These four 200-g kit epoxy resin samples shall each be from a batch of most recent production-scale manufacture, and are not required to be from the same batch as that used in preparing the duplicate panels specified in 6.3.1.3. All samples shall be identified as to:

- (1) Name and address of manufacturer,
- (2) Manufacturer's designation (trade name and code number),
- (3) Type of epoxy resin,
- (4) Batch number,
- (5) Date of manufacture,
- (6) Date of submittal,
- (7) Expiration date, and
- (8) Identification of agency submitting the samples.

6.3.1.2 A statement indicating that the products have not been rebranded shall accompany the samples. If rebranded, the names of the original manufacturers and original designations of the products shall be indicated. All information submitted will be treated as confidential.

6.3.1.3 *Duplicate Panels*—The manufacturer shall submit, along with the epoxy material samples called for in 6.3.1.1, a set of three panels, prepared in accordance with the procedures described in 7.2.1-7.2.3, respectively. These three panels shall be duplicates of those used in the generation of data for the test report (6.3.2). These panels shall be prepared with epoxy resin samples from the same numbered batch, and shall be code marked the same as the panels from which the data in the test report (6.3.2) were obtained.

6.3.2 *Test Report*—A dated and numbered report, certified by notarized affidavit, shall be furnished, giving the results of all applicable tests listed in Tables 2-4. The individual specimen and average values for each test shall be reported (see section 10.3.2). Each value reported shall be shown as being for a uniquely numbered specimen, the numbering of which shall be coded in the report in such a manner as to clearly establish the particular panel from which the specimen was cut and the particular batch of epoxy resin with which said panel was prepared and the date of preparation. Coded identification of the epoxy resin batch shall include the respective dates of manufacture and sizes of batch. Dates on which the different tests were performed shall be shown in the test report. The test report shall also cover all the requirements of 6.3-6.3.4. The actual pressure, temperature, and time of curing used in the preparation of the test panels shall be reported in the test report.

6.3.3 *Instruction Sheet*—The manufacturer shall submit an instruction sheet attached to the test report in accordance with 3.3.

6.3.4 *Tests*—The qualification tests shall consist of all the tests of this specification (Section 7) and shall include approval of the manufacturer instruction sheet. These tests shall be conducted by an organization approved by the procuring agency. Any changes shall be subject to the approval of that procuring activity.

6.4 *Quality Conformance Tests:*

6.4.1 *Sampling*—Two 200-g kits of epoxy material (see 9.1), taken at random from the production batch submitted for qualification, shall be tested. One kit shall be used for acceptance tests and the other shall be retained for retest if necessary. The storage conditions for the retained sample shall not exceed  $23 \pm 2^\circ\text{C}$  ( $73 \pm 4^\circ\text{F}$ ) and samples shall not be retained beyond the storage life.

6.4.2 *Tests*—Samples of each submitted lot of epoxy material delivered on contract or purchase order shall be subjected to the application life test described in 3.1.2. Lots shall be rejected if one or more of the specimens fail to comply with the requirements. Test reports, in duplicate, shall be furnished for all quality conformance tests and shall be signed by an authorized representative of the laboratory performing the test and by a designated representative of the procuring agency.

6.5 *Periodic Reevaluation*—Unless otherwise specified by the purchaser (see 6.1), epoxy material that has not passed the qualification tests, or that has previously passed the tests but has subsequently been modified in any manner, must be tested against this specification and shown to meet its requirements.

## 7. Test Methods

7.1 *Test Conditions*—Unless otherwise specified in the detailed test method, all specimens shall be conditioned at  $23 \pm 2^\circ\text{C}$  ( $73 \pm 4^\circ\text{F}$ ) and  $50 \pm 5\%$  relative humidity for a period of at least 7 days.

7.2 *Preparation of Test Panels:*

7.2.1 *Preparation of Test Panels for Tensile Lap Shear* (Table 2)—A total of two panels shall be prepared as follows (see Fig. 1):

7.2.1.1 Place a flat base plate, (labelled *B* in Fig. 1) 38.1 by 35.6 cm ~~minimum~~, (15 by 14 in.) minimum, upon a film of bagging material that is approximately 10 cm (4 in.) larger than the base plate in each direction (labelled *LBF* in Fig. 2).

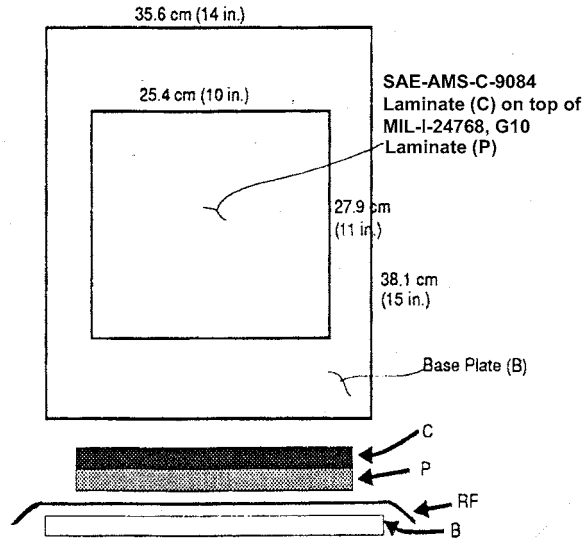

C = SAE-AMS-C-9084 Laminate, 20 nested plies of SAE-AMS-C-9084 Type 7781 glass cloth impregnated with test epoxy resin system  
 P = MIL-I-24768, G10 laminate, 0.317 cm (1/8-in. thick)  
 RF = release film  
 B = base plate

FIG. 1 Preparation of Test Panel for Tensile Lap Shear

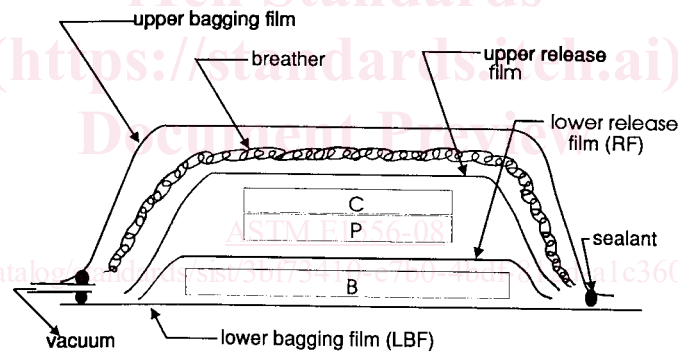

FIG. 2 Layup Scheme for Tensile Lap Shear Panel

7.2.1.2 Cover the base plate with a sheet of film to act as a release (labelled *RF* in Fig. 1).

7.2.1.3 Prepare a 27.9 by 25.4 cm (11 by 10 in.) piece of 0.317 cm (1/8 in.) thick MIL-I-24768, G10 laminate for bonding by sanding the bonding surface with 400 grit sand paper to remove surface gloss. Remove the sanding dust using a clean cloth saturated with isopropyl alcohol.

7.2.1.4 Center the MIL-I-24768, G10 laminate section of the panel (labelled *P* in Figs. 1 and 2) onto the release film on the base plate.

7.2.1.5 Lay up a laminate of 20 nested plies (approximately 27.9 by 25.4 cm (11 by 10 in.)) of SAE-AMS-C-9084 Type 7781 glass cloth impregnated with the epoxy resin system (labelled *C* in Figs. 1 and 2) directly on top of the G10 laminate (*P* in Figs. 1 and 2). The amount of resin to use to impregnate the glass cloth shall be selected so that the final cured laminate has a fiber content of  $55 \pm 4\%$  by volume. All 20 plies shall be oriented so that the warp yarns in the fabric weave are in the 25.4 cm (10 in.) direction of the layup.

7.2.1.6 Cover the SAE-AMS-C-9084 laminate with a release film that overhangs the laminate by at least 5 cm (2 in.) on all sides (Fig. 2).

7.2.1.7 Cover the upper release film with a layer of heavy fiberglass breather fabric to provide for a uniform venting of the vacuum bag during curing of the laminate (Fig. 2).

7.2.1.8 Place strip of sealant along the outer portion of the lower sheet of bagging material and fit a vacuum tube through the sealant (see Fig. 2).

7.2.1.9 Position an upper sheet of the bagging material over the layup stack and seal to the sealant around the edges (Fig. 2).

7.2.1.10 Apply a vacuum of up to 72 cm (28.5 in.) of mercury (14 psig) to the bag.

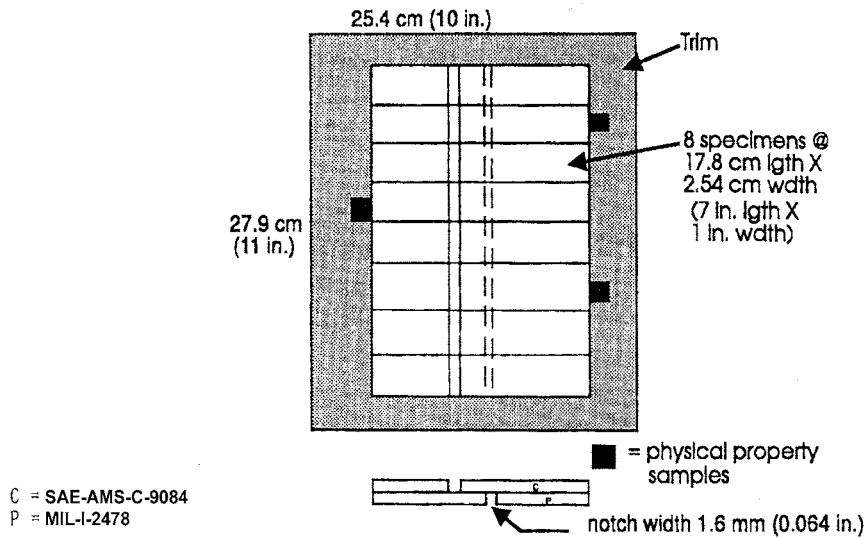

FIG. 3 Specimen Machining Diagram for Tensile Lap Shear Panel

7.2.1.11 Smooth out the laminate and work out the air and excess resin using the flat edge of a smooth tool.

7.2.1.12 The entire bagged assembly is to be cured in accordance with the following conditions:

(1) Allow to cure, under vacuum, for 24 h at  $23 \pm 2^\circ\text{C}$  ( $73 \pm 4^\circ\text{F}$ ), and

(2) Remove vacuum bag and allow to cure for six additional days (a total of seven days) at  $23 \pm 2^\circ\text{C}$  ( $73 \pm 4^\circ\text{F}$ ) prior to further preparation.

7.2.1.13 The cured panel shall be used to prepare tensile lap shear specimens (see 7.3.1). Fig. 3 illustrates the specimen machining diagram. Physical property specimens shall also be obtained from the cured panel and used to determine cured laminate specific gravity (Test Methods D 792), resin content (Test Method D 2584), fiber content (Test Method D 2584), and void content (Test Methods D 2734).

7.2.2 Preparation of Test Panel for Apparent Horizontal Shear Strength (Table 3)—A panel shall be prepared as follows (see Figs. 4 and 5):

7.2.2.1 Place a flat base plate, (labelled B in Fig. 5) 25.4 by 25.4 cm minimum (10 by 10 in.) minimum, upon a film of bagging material that is approximately 10 cm (4 in.) larger than the base plate in each direction.

7.2.2.2 Cover the base plate with a sheet of film to act as a release (Fig. 5).

7.2.2.3 Layup a laminate of 20 nested plies (approximately 15.2 by 15.2 cm (6 by 6 in.)) of SAE-AMS-C-9084 type 7781 glass cloth impregnated with the epoxy resin system (Fig. 4 and item (c) in Fig. 5) directly on top of the release film. The amount of resin used to impregnate the glass cloth shall be selected so that the final cured laminate has a fiber content of  $55 \pm 4\%$  by volume.

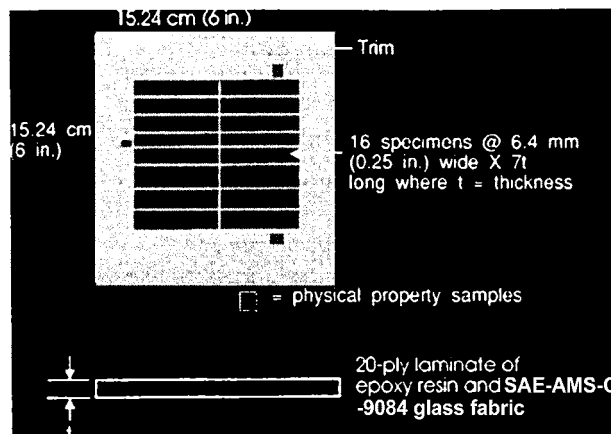

FIG. 4 Apparent Horizontal Shear Strength Panel