



Designation: F303-02 Designation: F 303 - 08

Standard Practices for Sampling for Particles in Aerospace Fluids and Components¹

This standard is issued under the fixed designation F 303; the number immediately following the designation indicates the year of original adoption or, in the case of revision, the year of last revision. A number in parentheses indicates the year of last reapproval. A superscript epsilon (ϵ) indicates an editorial change since the last revision or reapproval.

1. Scope

1.1 These practices cover sampling procedures for use in determining the particle cleanliness of liquids and liquid samples from components. Three practices, A, B, and C, have been developed on the basis of component geometry in order to encompass the wide variety of configurations. These practices establish guidelines to be used in preparing detailed procedures for sampling specific components.

NOTE 1—The term cleanliness used in these practices refers to solid particles in the liquid. It does not generally cover other foreign matter such as gases, liquids, and products of chemical degradation. Cleanliness with respect to particulate contamination does not necessarily give any indication of the other types of contamination.

1.2 All components, regardless of application, may be tested provided (1) the fluid medium selected is completely compatible with the materials, packing and fluid used in the test component, and test apparatus, and (2) the fluid is handled in accordance with the manufacturer's recommendations and precautions. A liquid shall be used as the test fluid medium. These test fluids may be flushing, rinsing, packing, end use operating, or suitable substitutes for end use operating fluids. (**Warning**—Practices for sampling surface cleanliness by the vacuum cleaner technique (used on clean room garments and large storage tanks) sampling gaseous fluids and handling hazardous fluids such as oxidizers, acids, propellants, and so forth, are not within the scope of the practices presented; however, they may be included in addendums or separate practices at a later date.)

Substitute fluids are recommended in place of end item fluids for preassembly cleanliness determinations on components using hazardous end item fluids. After obtaining the sample, the substitute fluid must be totally removed from the test part with particular caution given to the possibility of trapped fluid. It is hazardous to use a substitute fluid for testing assembled parts where the fluid can be trapped in dead ends, behind seals, and so forth.)

NOTE 2—The word fluid used in these practices shall be assumed to be a liquid unless otherwise stated.

1.3 The cleanliness of assemblies with or without moving parts may be determined at the time of test; however, movement of internal component parts during the test will create unknown quantities of contamination from wear. Practice B covers configurations requiring dynamic actuation to achieve a sample. The practice does not differentiate between built-in particles and wear particles.

NOTE 3—Defining allowable cleanliness limits is not within the scope of these practices.

1.4 The three practices included are as follows:

	Sections
Practice A—Static Fluid Sampling (Method for extracting fluid from the test article for analysis. This applies to components that have a cavity from which fluid may be extracted)	5-13
Practice B—Flowing Fluid Sampling (Method for flushing contaminants from the test article for analysis. This applies to components which fluid can pass (1) directly through, or (2) pass into and out of by cycling)	14-22

¹ These practices are under the jurisdiction of ASTM Committee E21 on Space Simulation and Applications of Space Technology and are the direct responsibility of Subcommittee E21.05 on Contamination.

Current edition approved Oct. 10, 2002. Published November 2002. Originally published as D2429-65T. Redesignated F303 in 1970. Last previous edition F303-78 (1996):

Current edition approved Nov. 1, 2008. Published December 2008. Originally approved in 1965 as D 2429-65 T. Redesignated F 303 in 1970. Last previous edition approved in 2002 as F 303 - 02.

Practice C—Rinse Fluid Sampling (Method for rinsing contaminants from the test article's surfaces. The rinse fluid is analyzed for contamination. This applies to components that do not have a fluid cavity or for other reasons are not adaptable to Practices A and B)

23-31

1.5 *This standard does not purport to address all of the safety concerns, if any, associated with its use. It is the responsibility of the user of this standard to establish appropriate safety and health practices and determine the applicability of regulatory limitations prior to use.*

2. Referenced Documents

2.1 ASTM Standards:²

D 1836 Specification for Commercial Hexanes

F 311 Practice for Processing Aerospace Liquid Samples for Particulate Contamination Analysis Using Membrane Filters

F 312 Test Methods for Microscopical Sizing and Counting Particles from Aerospace Fluids on Membrane Filters

F 313 Test Method for Insoluble Contamination of Hydraulic Fluids by Gravimetric Analysis³

2.2 Military Standards:

MIL-T-27602 Trichlorine Oxygen Propellant Compatibles⁴

MIL-H-6083 Hydraulic Fluid Petroleum Base for Pressure⁴

MIL-H-5606 Hydraulic Fluid Petroleum Base for Aircarrier Missiles and Ordinance⁴

3. Terminology

3.1 Definitions:

3.1.1 *analytical membrane*—a membrane filter used to collect the contaminant particles for analysis.

3.1.2 *azeotropic mixture*—a solution of two or more liquids, the composition of which does not change upon distillation. Also known as azeotrope.

3.1.3 *blank analysis*—sometimes referred to as “fluid tare,” “control level,” “reference contamination level,” or “background level.” The blank analysis is the particulate contamination level of the test fluid when the test part is omitted.

3.1.4 *cleanup membrane*—a membrane used to filter the contaminant particles from the fluid medium.

3.1.5 *component*—an individual piece or a complete assembly of individual pieces.

3.1.6 *field filter holder*—a throw-away or reusable cartridge containing an analytical membrane filter.

3.1.7 *initial cleanliness*—the measure of contamination removed from the test component at the time of test excluding that defined by operating cleanliness.

3.1.8 *membrane tare*—sometimes referred to as “blank count” or “control filter.” When applied to microscope methods, the membrane tare is the quantity of particles determined to be on the filter before the test fluid is filtered. When applied to gravimetric methods, the membrane tare is an amount of weight increase imparted to the control filter when uncontaminated test fluid is passed through.

3.1.9 *operating cleanliness*—the measure of contaminants generated by moving parts in the component during a specified period of dynamic operation.

3.1.10 *solvent filtering dispenser*—an apparatus to dispense a stream of 2.0 μm or finer membrane filtered fluid.

3.1.11 *system tare*—The measure of contamination determined by replacing the test component with a connecting fitting and following the cleanliness test procedure as if checking the test component.

4. Summary of Practices

4.1 Cleanliness is determined by sampling and analyzing fluid that has been in contact with the surface being analyzed. Specific methods are recommended; however, other methods have been recognized due to the wide variety of components and different test equipment used by industry. Recommended and alternative methods are given in Fig. 1, Fig. 2, and Fig. 3.

PRACTICE A—STATIC FLUID SAMPLING

5. Scope

5.1 This practice covers procedures for determining the particulate contamination level of fluids from components that have a cavity from which fluid may be extracted.

² Annual Book of ASTM Standards, Vol 06.04.

² For referenced ASTM standards, visit the ASTM website, www.astm.org, or contact ASTM Customer Service at service@astm.org. For *Annual Book of ASTM Standards* volume information, refer to the standard's Document Summary page on the ASTM website.

³ Annual Book of ASTM Standards, Vol 14.02.

³ Withdrawn. The last approved version of this historical standard is referenced on www.astm.org.

⁴ Annual Book of ASTM Standards, Vol 15.03.

⁴ Available from Standardization Documents Order Desk, Bldg. 4 Section D, 700 Robbins Ave., Philadelphia, PA 19111-5098, Attn: NPODS.

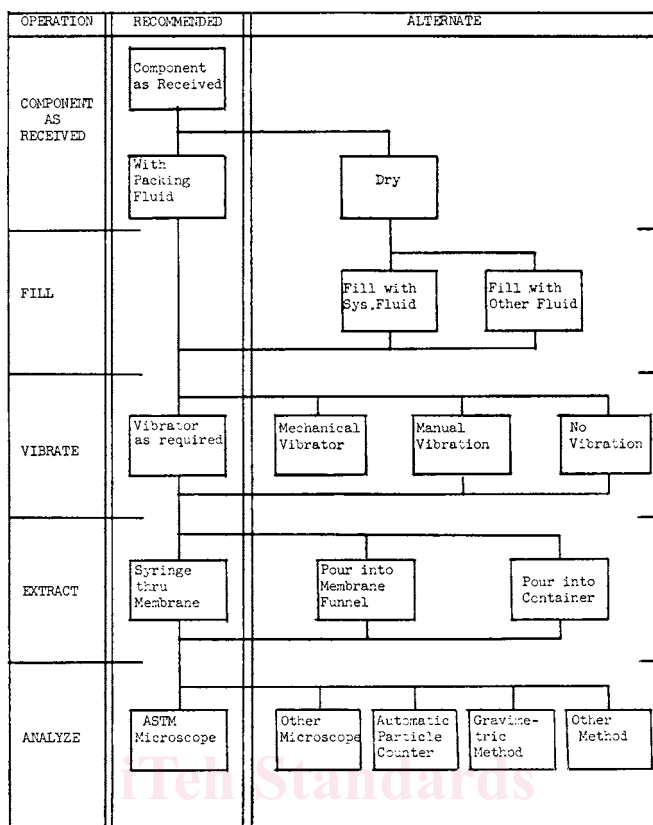

FIG. 1 Recommended and Alternative Methods for Static Fluid Sampling (Practice A)

6. Summary of Practice

6.1 Fluid is extracted from the component and analyzed to determine the particulate contamination level. Recommended and alternative methods are given in Fig. 1.

6.2 It is recommended that all operations of this practice be conducted in a dust controlled area. Cleanliness level of the dust controlled area shall be consistent with the component contamination limits.

7. Significance and Use

7.1 Although a cleaning action is imparted to the test component, it is not the intent of this practice to serve as a cleaning procedure. Components are normally cleaner after each consecutive test; thus repeated tests may be used to establish process limits for a given component (Fig. 4). A specific set of test parameters must be supplied by the agency specifying cleanliness limits. Fig. 1, Fig. 2, and Fig. 3 may be used as a guide to establish the desired parameters of test fluid, vibration, extraction, and analysis.

7.2 The curve in Fig. 4 shows the typical behavior of a component when tested for cleanliness several consecutive times. Stabilization generally occurs before the fifth successive run. The stabilized region starts where a horizontal line through the maximum stabilized value intersects the curve.

7.3 The allowable cleanliness limit of a test component should be based on the cleanliness requirements of the system in which it will be used and the assigned value should be greater than the maximum stabilized value. When defining the allowable cleanliness limits, an important consideration is that the accuracy of the results decreases as the allowable limit value approaches the stabilized value.

8. Apparatus

- 8.1 Apparatus, as described in Practice F 313.
- 8.2 Apparatus, as described in Test Methods F 312 or as described in Practice F 311.
- 8.3 Automatic Particle Counter, as required.
- 8.4 Vibration Equipment, as specified.
- 8.5 Apparatus Setup for Removing Component Fluid Sample, as shown in Fig. 4.

NOTE 4—Any suitable syringe and solvent dispensing devices may be used.

- 8.6 Apparatus Setup for Providing Filtered Fluids, as shown in Fig. 5 (Note 4).

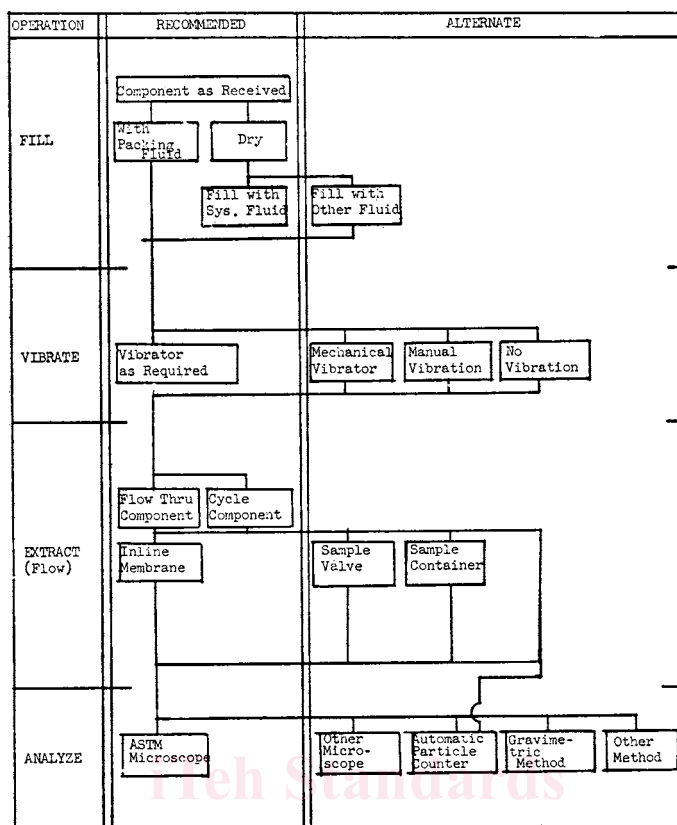

FIG. 2 Recommended and Alternative Methods for Flow Through Sampling (Practice B)

9. Reagents ⁵

9.1 *Purity of Reagents*—Reagent grade chemicals shall be used in all tests. Unless otherwise indicated, it is intended that all reagents shall conform to the specifications of the Committee on Analytical Reagents of the American Chemical Society, where such specifications are available.⁶ Other grades may be used, provided it is first ascertained that the reagent is of sufficiently high purity to permit its use without lessening the accuracy of the determination.

9.2 Reagents must be compatible with the materials, fluid, and seals used in the component and apparatus.

9.3 All reagents shall be prefiltered through a 2- μ m or finer absolute membrane filter prior to use unless this requirement is impractical due to the fluid used or sizes monitored in which case the user must filter as necessary.

9.4 Low surface tension reagents commonly used are as follows:

9.4.1 *Petroleum Ether*,

9.4.2 *Hexane*, in accordance with Specification D 1836.

9.4.3 *Isopropyl Alcohol*,

9.4.4 *Fluorocarbons*,

9.4.5 *Mineral Spirits*,

9.4.6 *Trichloroethylene*, in accordance with MIL-T-27602, and

9.4.7 *Azeotropic mixture* of ethyl acetate (47 % vol) and cyclohexane (53 % vol).

9.4.8 *Deionized water*.

NOTE 5—Methyl-chloroform, used in these practices, is toxic, and is being phased out for many applications. Methyl-chloroform has been replaced

⁵ Available from Standardization Documents Order Desk, Bldg. 4 Section D, 700 Robbins Ave., Philadelphia, PA 19111-5098, Attn: NPODS.

⁵ A Material Safety Data Sheet (MSDS) can be obtained from the vendor. The following website can also provide MSDS's for all materials: www.msdssearch.com/DBlinksN.htm. Note that the specific fluorocarbon must be identified.

⁶ A Material Safety Data Sheet (MSDS) can be obtained from the vendor. The following website can also provide MSDS's for all materials: www.msdssearch.com/DBlinksN.htm. Note that the specific fluorocarbon must be identified.

⁶ *Reagent Chemicals, American Chemical Society Specifications*, American Chemical Society, Washington, DC. For Suggestions on the testing of reagents not listed by the American Chemical Society, see *Annual Standards for Laboratory Chemicals*, BDH Ltd., Poole, Dorset, U.K., and the *United States Pharmacopeia and National Formulary*, U.S. Pharmacopeial Convention, Inc. (USPC), Rockville, MD.

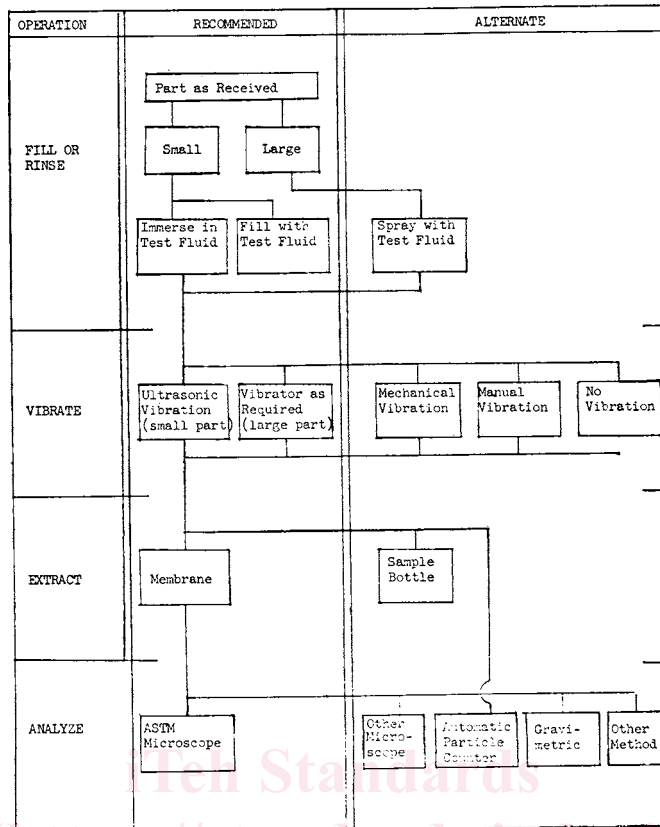

FIG. 3 Recommended and Alternative Methods for Rinse Fluid Sampling (Practice C)

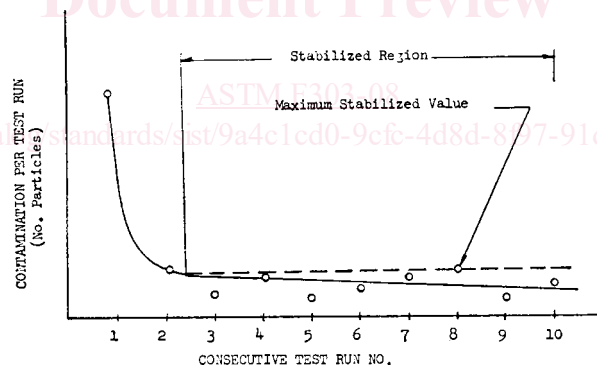

FIG. 4 Contamination per Test Run Versus Consecutive Test Run Number

in this edition of these practices. The replacement solvents were selected based on tests and analyses performed by The Aerospace Corporation and described in SMC-TR-95-28.⁷

NOTE 6—Trichloroethylene has been labeled a potential human carcinogen by the Environmental Protection Agency. Use should be restricted to limit human exposure.

10. Preparation of Apparatus

10.1 *Installation Requirements for Fig. 6*—The following requirements must be accomplished prior to and during assembly of the apparatus shown in Fig. 6. (**Warning**—All connections must be finger tight only.)

⁷ Reagent Chemicals, American Chemical Society Specifications, American Chemical Society, Washington, DC. For Suggestions on the testing of reagents not listed by the American Chemical Society, see *Annual Standards for Laboratory Chemicals*, BDH Ltd., Poole, Dorset, U.K., and the *United States Pharmacopeia and National Formulary*, U.S. Pharmacopeial Convention, Inc. (USPC), Rockville, MD.

⁷ Aerospace Corporation Report No. TR95 (5448)-1, "Non-Volatile Residue Solvent Replacement." Available from The Aerospace Corporation, P.O. Box 92957, Los Angeles, CA 90009-2957.

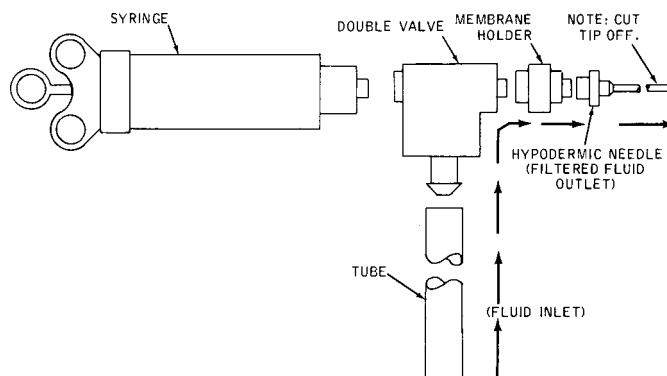

FIG. 5 Apparatus Setup for Providing Filtered Fluids

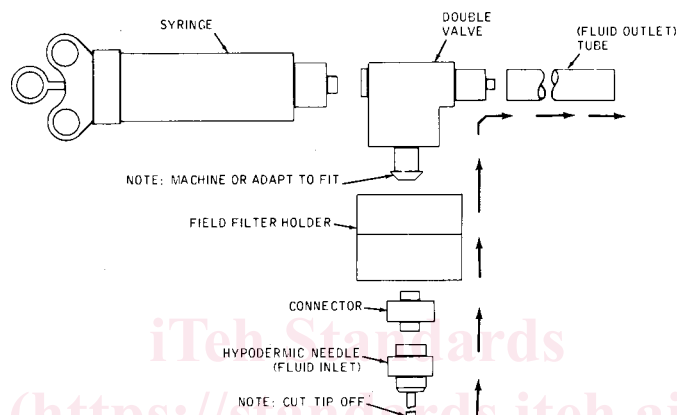

FIG. 6 Apparatus Setup for Removing Component Fluid Sample

10.1.1 Install the double valve and fluid outlet plastic tube.

10.1.2 Remove caps or plugs, or both, from the field filter holder and place them in a covered, precleaned, petri dish.

10.1.3 Install the field filter holder onto the double valve, taking care to place the inlet side of the field filter holder towards the fluid being withdrawn.

10.1.4 Install fluid inlet needle onto the monitor. (**Warning**—The fluid inlet needle must be precleaned prior to each usage.)

10.2 *General Requirements for Fig. 6:*

10.2.1 A control blank must be accomplished on the apparatus setup before fluid is withdrawn for component fluid sampling.

10.2.2 It is recommended that the field filter holders be used one time only for component fluid sampling. However, cleaning in sufficient numbers might warrant their reuse, provided it is first determined that the monitors are sufficiently cleaned to permit their reuse without lessening the accuracy of the determination.

10.2.3 Always actuate the syringe plunger slowly when filling or ejecting fluid.

10.2.4 For ease of actuation, the syringe plunger must be lubricated. If the plunger is extremely hard to actuate, check the plunger seal for swelling which would indicate noncompatibility with the fluids utilized.

10.2.5 In order to minimize seal swell, it is desirable to remove the syringe plunger when not in use. Lubricate prior to each reassembly.

10.3 *Installation Requirements for Fig. 7*—The following requirements must be accomplished prior to and during assembly on the apparatus shown in Fig. 7. (**Warning**—See 10.1.)

10.3.1 Eject all fluid from the syringe.

10.3.2 Install the hypodermic adapter and fluid outlet needle onto the double valve. (**Warning**—The hypodermic adapter and fluid outlet needle must be precleaned and the hypodermic adapter filter disk replaced prior to each usage.)

10.3.3 Exercise extreme caution to assemble the hypodermic adapter in the correct configuration. Tighten sufficiently to effect a seal.

10.4 *General Requirements for Fig. 5:*

10.4.1 Periodic control analysis is required in order to guarantee an acceptable contamination level of the component replacement fluid.

10.4.2 Prior to initial use, replace the “as received” hypodermic adapter backup screen with a like diameter backup screen, approximately 35 mesh (500- μ m opening), or photoetched screen with 70- μ m holes.

10.4.3 The addition of a field filter holder between the double valve and fluid inlet tube will increase the filtration capability. This application would be governed by the quality and condition of the fluid being filtered. (**Warning**—If utilizing a field filter