

---

---

**Fine ceramics (advanced ceramics,  
advanced technical ceramics) —  
Methods of test for reinforcements —  
Determination of tensile properties of  
filaments at ambient temperature**

*Céramiques techniques — Méthodes d'essai pour renforts —  
Détermination des propriétés en traction du filament à température  
ambiante*  
**(standards.iteh.ai)**

[ISO 19630:2017](https://standards.iteh.ai/catalog/standards/sist/2458a94e-7346-4133-9e83-587799a7a634/iso-19630-2017)

<https://standards.iteh.ai/catalog/standards/sist/2458a94e-7346-4133-9e83-587799a7a634/iso-19630-2017>



**iTeh STANDARD PREVIEW**  
**(standards.iteh.ai)**

ISO 19630:2017

<https://standards.iteh.ai/catalog/standards/sist/2458a94e-7346-4133-9e83-587799a7a634/iso-19630-2017>



**COPYRIGHT PROTECTED DOCUMENT**

© ISO 2017, Published in Switzerland

All rights reserved. Unless otherwise specified, no part of this publication may be reproduced or utilized otherwise in any form or by any means, electronic or mechanical, including photocopying, or posting on the internet or an intranet, without prior written permission. Permission can be requested from either ISO at the address below or ISO's member body in the country of the requester.

ISO copyright office  
Ch. de Blandonnet 8 • CP 401  
CH-1214 Vernier, Geneva, Switzerland  
Tel. +41 22 749 01 11  
Fax +41 22 749 09 47  
[copyright@iso.org](mailto:copyright@iso.org)  
[www.iso.org](http://www.iso.org)

# Contents

	Page
<b>Foreword</b> .....	<b>iv</b>
<b>1 Scope</b> .....	<b>1</b>
<b>2 Normative references</b> .....	<b>1</b>
<b>3 Terms, definitions and symbols</b> .....	<b>1</b>
<b>4 Principle</b> .....	<b>3</b>
<b>5 Apparatus</b> .....	<b>3</b>
<b>6 Test specimens</b> .....	<b>3</b>
<b>7 Test specimen preparation</b> .....	<b>3</b>
<b>8 Number of test specimens</b> .....	<b>5</b>
<b>9 Test procedure</b> .....	<b>5</b>
9.1 Displacement rate.....	5
9.2 Determination of the gauge length.....	5
9.3 Determination of the initial cross-section area.....	5
9.4 Testing technique.....	5
9.4.1 General.....	5
9.4.2 Load cell.....	5
9.4.3 Test specimen mounting.....	5
9.4.4 Measurements.....	6
9.4.5 Test validity.....	6
<b>10 Calculation of results</b> .....	<b>6</b>
10.1 Tensile strength.....	6
10.1.1 Determination of maximum tensile force.....	6
10.1.2 Calculation of tensile strength.....	6
10.2 Calculation of the load train compliance, $C_1$ .....	6
10.3 Strain.....	7
10.4 Young modulus.....	8
10.5 Fracture strain.....	8
<b>11 Test report</b> .....	<b>9</b>
<b>Bibliography</b> .....	<b>10</b>

## Foreword

ISO (the International Organization for Standardization) is a worldwide federation of national standards bodies (ISO member bodies). The work of preparing International Standards is normally carried out through ISO technical committees. Each member body interested in a subject for which a technical committee has been established has the right to be represented on that committee. International organizations, governmental and non-governmental, in liaison with ISO, also take part in the work. ISO collaborates closely with the International Electrotechnical Commission (IEC) on all matters of electrotechnical standardization.

The procedures used to develop this document and those intended for its further maintenance are described in the ISO/IEC Directives, Part 1. In particular the different approval criteria needed for the different types of ISO documents should be noted. This document was drafted in accordance with the editorial rules of the ISO/IEC Directives, Part 2 (see [www.iso.org/directives](http://www.iso.org/directives)).

Attention is drawn to the possibility that some of the elements of this document may be the subject of patent rights. ISO shall not be held responsible for identifying any or all such patent rights. Details of any patent rights identified during the development of the document will be in the Introduction and/or on the ISO list of patent declarations received (see [www.iso.org/patents](http://www.iso.org/patents)).

Any trade name used in this document is information given for the convenience of users and does not constitute an endorsement.

For an explanation on the voluntary nature of standards, the meaning of ISO specific terms and expressions related to conformity assessment, as well as information about ISO's adherence to the World Trade Organization (WTO) principles in the Technical Barriers to Trade (TBT) see the following URL: [www.iso.org/iso/foreword.html](http://www.iso.org/iso/foreword.html). (standards.iteh.ai)

This document was prepared by Technical Committee ISO/TC 206, *Fine ceramics*.

ISO 19630:2017

<https://standards.iteh.ai/catalog/standards/sist/2458a94e-7346-4133-9e83-587799a7a634/iso-19630-2017>

# Fine ceramics (advanced ceramics, advanced technical ceramics) — Methods of test for reinforcements — Determination of tensile properties of filaments at ambient temperature

## 1 Scope

This document specifies the conditions for the determination of tensile properties of single filaments of ceramic fibre such as tensile strength, Young modulus and fracture strain. The method applies to continuous ceramic filaments taken from tows, yarns, braids and knittings, which have strain to fracture less than or equal to 5 %.

The method does not apply to carbon fibres that exhibit nonlinear stress-strain curve. The method does not apply to checking the homogeneity of strength properties of fibres, nor to assessing the effects of volume under stress. Statistical aspects of filament failure are not included.

## 2 Normative references

The following documents are referred to in the text in such a way that some or all of their content constitutes requirements of this document. For dated references, only the edition cited applies. For undated references, the latest edition of the referenced document (including any amendments) applies.

ISO 7500-1, *Metallic materials — Calibration and verification of static uniaxial testing machines — Part 1: Tension/compression testing machines — Calibration and verification of the force-measuring system*

ISO 19634, *Fine ceramics (advanced ceramics, advanced technical ceramics) — Ceramic composites — Notations and symbols*

ISO 20501, *Fine ceramics (advanced ceramics, advanced technical ceramics) — Weibull statistics for strength data*

EN 1007-1, *Advanced technical ceramics — Ceramic composites — Methods of test for reinforcements — Part 1: Determination of size content*

EN 1007-3, *Advanced technical ceramics — Ceramic composites — Methods of test for reinforcements — Part 3: Determination of filament diameter and cross-section area*

## 3 Terms, definitions and symbols

For the purposes of this document, the terms, definitions and symbols given in ISO 19634 and the following apply.

ISO and IEC maintain terminological databases for use in standardization at the following addresses:

- IEC Electropedia: available at <http://www.electropedia.org/>
- ISO Online browsing platform: available at <http://www.iso.org/obp>

### 3.1

#### gauge length

$L_0$

initial distance between two reference points on the filament

**3.2**  
**test specimen length**

$L_f$   
initial distance between the gripped ends of the filament

**3.3**  
**initial cross-section area**

$A_0$   
initial area of the cross section of the filament within the *gauge length* (3.1)

**3.4**  
**maximum tensile force**

$F_m$   
highest recorded tensile force on the test specimen when tested to failure

**3.5**  
**tensile stress**

$\sigma$   
tensile force supported by the test specimen divided by the *initial cross-section area* (3.3)

**3.6**  
**tensile strength**

$\sigma_m$   
ratio of the maximum tensile force to the *initial cross-section area* (3.3)

**3.7**  
**longitudinal deformation**

$\Delta L$   
increase of the *gauge length* (3.1) during the tensile test

iTeh STANDARD PREVIEW  
(standards.iteh.ai)

**3.8**  
**total compliance**

$C_t$   
inverse of the slope in the linear part of the tensile force-displacement curve

ISO 19630:2017  
<https://standards.iteh.ai/catalog/standards/sist/2458a94e-7346-4133-9e83-587799a7a634/iso-19630-2017>

**3.9**  
**load train compliance**

$C_l$   
ratio of the cross-head displacement excluding any test specimen contribution to the corresponding force during the tensile test

**3.10**  
**strain**

$\varepsilon$   
ratio of the *longitudinal deformation* (3.7) to the *gauge length* (3.1)

**3.11**  
**fracture strain**

$\varepsilon_m$   
strain at failure of the test specimen

**3.12**  
**Young modulus**

$E$   
slope of the linear part of the tensile stress-strain curve

**3.13**  
**elementary unit**

smallest commercially available unit of a given product

Note 1 to entry: For fibre, this is usually a spool.

## 4 Principle

A ceramic filament is loaded in tension. The test is performed at constant displacement rate up to failure. Force and cross-head displacement are measured and recorded simultaneously. When required, the longitudinal deformation is derived from the cross-head displacement using a compliance correction.

## 5 Apparatus

**5.1 Test machine**, which shall be equipped with a system for measuring the force applied to the test specimen which shall conform to grade 1 according to ISO 7500-1. Additionally, the machine shall be equipped with a system for measuring the cross-head displacement with accuracy better than 1  $\mu\text{m}$ .

**5.2 Load train**, in which the grips shall align the test specimen with the direction of the force. Slippage of the filament in the grips shall be prevented.

**5.3 Adhesive**, such as epoxy resin or sealing wax, for fixing the filament ends to the grip.

**5.4 Data recording system**, which, when calibrated, may be used to record force-displacement curves. The use of a digital data recording system is recommended.

## 6 Test specimens

Specimens with a gauge length of 25 mm shall be used to establish the force-displacement curves.

Specimens with a gauge length of 10 mm and 50 mm shall be used to determine the load train compliance,  $C_1$ .

The tolerance on the gauge length is  $\pm 1$  mm.

ISO 19630:2017  
<http://standards.iteh.ai/catalog/standards/sist/2458a94e-7346-4133-9e83-587799a7a634/iso-19630-2017>

## 7 Test specimen preparation

Extreme care shall be taken during test specimen preparation to ensure that the procedure is repeatable from test specimen to test specimen and to avoid handling damage.

**NOTE 1** The introduction of damage during test specimen preparation may result in the weakening of the filament.

During test specimen preparation, and in particular when extracting a filament from the tow, the ratio of the amount of damaged filaments to the total number of extracted filaments should be minimized.

**NOTE 2** An example of a device to prevent damage during test specimen manipulation and mounting is shown in [Figure 1](#). This test specimen preparation uses a window tab of thin paper, metal or plastic cut. The length of the window is equal to the gauge length of the filament test specimen. A suitable adhesive, such as epoxy resin, cement or sealing wax, is used for affixing the filament to the ends of the mounting tab.

**NOTE 3** Another device that can be used to prevent damage during test specimen manipulation and mounting is shown in [Figure 2](#).

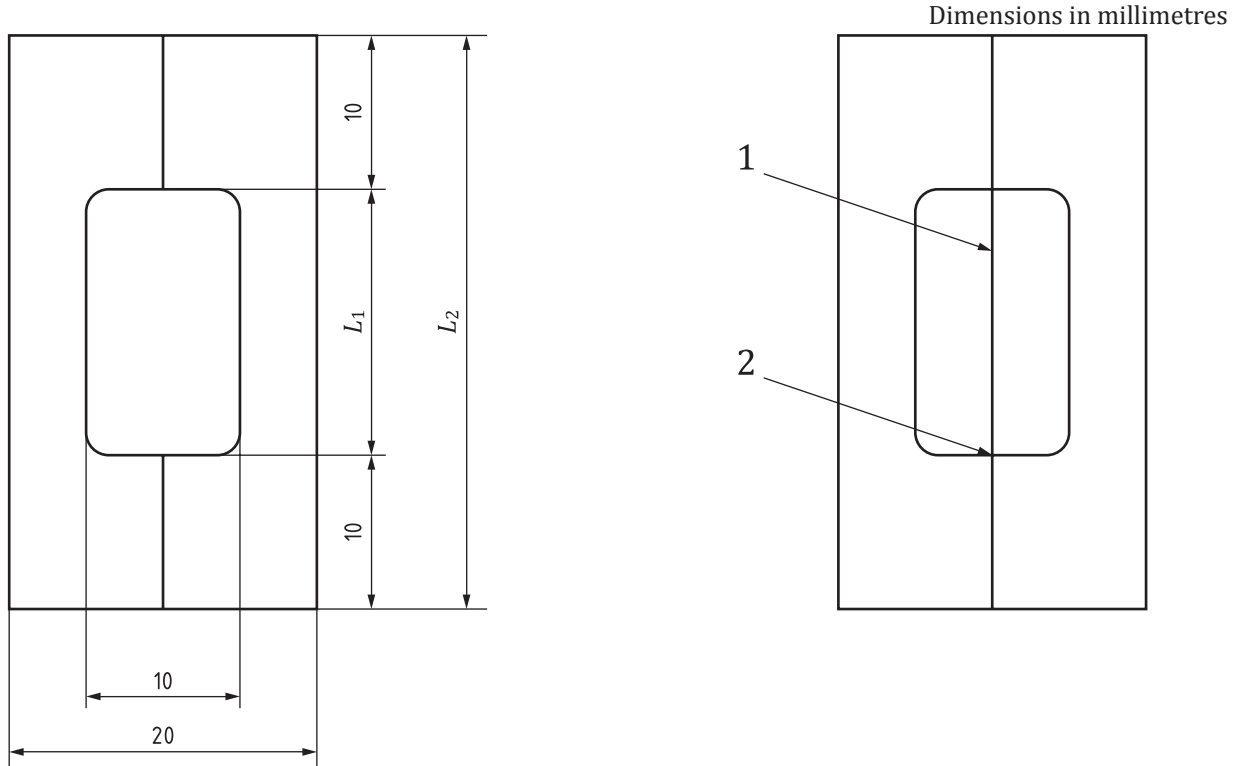

- Key**  
 1 filament  
 2 glue

**iTeh STANDARD PREVIEW**  
**(standards.iteh.ai)**

$L_1$	$L_2$	ISO 19630:2017
$10 \pm 0,5$	$30 \pm 1$	<a href="https://standards.iteh.ai/catalog/standards/sist/2458a94e-7346-4133-9e83-587799a7a634/iso-19630-2017">https://standards.iteh.ai/catalog/standards/sist/2458a94e-7346-4133-9e83-587799a7a634/iso-19630-2017</a>
$25 \pm 0,5$	$45 \pm 1$	
$50 \pm 0,5$	$70 \pm 1$	

**Figure 1 — Assembly of a test specimen**

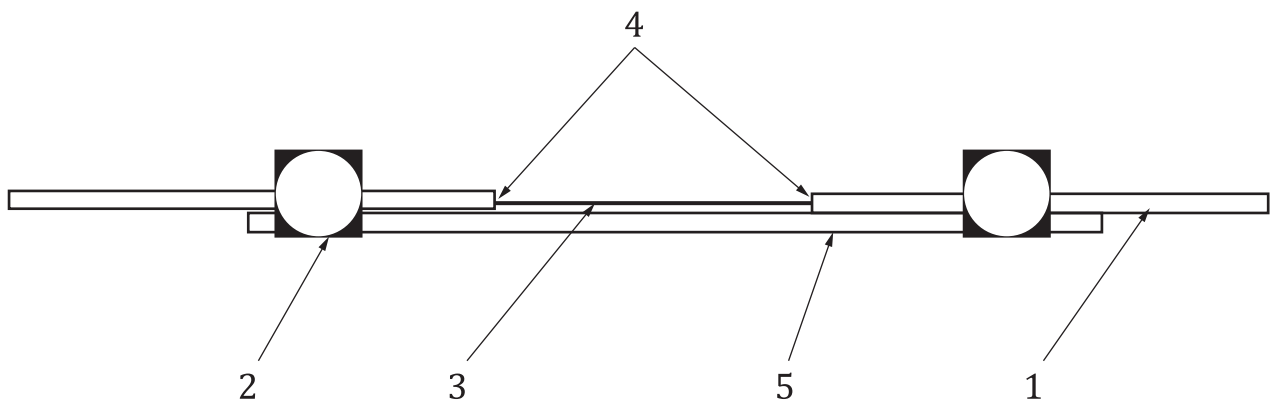

- Key**
- |                              |                  |
|------------------------------|------------------|
| 1 alumina tubes              | 4 ceramic cement |
| 2 temporary screw attachment | 5 alumina rod    |
| 3 test specimen              |                  |

**Figure 2 — Alternative assembly of a test specimen**



## 8 Number of test specimens

Prepare at least 20 test specimens from each elementary unit to enable 20 measurements to be made.

Removal of any size present makes it easier to prepare good specimens. The size shall be removed in accordance with EN 1007-1.

For the determination of strain-related properties, three additional tests at each gauge length of 10 mm and 50 mm are required in order to establish load train compliance,  $C_1$ .

If a statistical evaluation is required, the number of test specimens at a gauge length of 25 mm shall be in accordance with ISO 20501.

NOTE Compliance determination is not required if only strength needs to be determined.

## 9 Test procedure

### 9.1 Displacement rate

A displacement rate that allows specimen rupture within 1 min shall be used.

The displacement rate and the loading mode shall be reported.

### 9.2 Determination of the gauge length

The gauge length is measured to an accuracy of  $\pm 0,1$  mm.

### 9.3 Determination of the initial cross-section area

The initial cross-section area is measured in accordance with EN 1007-3.

NOTE In principle, the initial cross-section area is to be determined on the filament to be tested. In practice, this can be achieved by sampling the lengths to be tested from a single filament at intermittent locations and using the parts in between for cross-section measurement. This assumes that for the lengths of filament to be tested, the cross section does not vary significantly with the length.

An alternative method consists of measuring the filament cross section after fracture from a transverse cross section taken from the part of the grips still containing embedded filament. In this case, care has to be taken not to damage the filament during preparation and handling.

### 9.4 Testing technique

#### 9.4.1 General

Perform the following steps in a sequential order.

#### 9.4.2 Load cell

Zero the load cell.

#### 9.4.3 Test specimen mounting

Mount the specimen in the load train with its longitudinal axis coinciding with that of the test machine. Care shall be taken not to induce torsional loads or surface damage to the filament. Before applying the load, i.e. with the mounting unstrained, cut or burn through both sides of the window tab at mid-gauge. If burning is used, care shall be taken to avoid exposing the specimen to the flame. As the filament is very fragile, the test specimen breaks occasionally during this step.