



Designation: B660 – 08

Standard Practices for Packaging/Packing of Aluminum and Magnesium Products¹

This standard is issued under the fixed designation B660; the number immediately following the designation indicates the year of original adoption or, in the case of revision, the year of last revision. A number in parentheses indicates the year of last reapproval. A superscript epsilon (ϵ) indicates an editorial change since the last revision or reapproval.

This standard has been approved for use by agencies of the Department of Defense.

1. Scope*

1.1 These practices describe methods of packaging/packing aluminum and magnesium products, in preparation for storage or shipment, both foreign and domestic. Assuming proper and normal handling in transit, these practices are designed to deliver the products to their destination in good condition. For DoD redistribution, see Supplementary Requirements.

1.2 The values stated in inch-pound units are to be regarded as standard. The values given in parentheses are mathematical conversions to SI units that are provided for information only and are not considered standard.

1.3 Aluminum and magnesium products must be preserved and packed so as to be adequately protected from possible damage during shipment and storage. Major damage types are:

1.3.1 Mechanical, including bending, crushing, denting, scratching, or gouging during handling and storage; and abrasions resulting from vibration during transport of the material.

1.3.2 Corrosion, or water stain, resulting from exposure of packed material to water, either externally applied, or as condensate caused by temperature variations in a humid atmosphere.

1.4 *This standard does not purport to address all of the safety concerns, if any, associated with its use. It is the responsibility of the user of this standard to establish appropriate safety and health practices and determine the applicability of regulatory limitations prior to use.*

2. Referenced Documents

2.1 ASTM Standards:²

[D779 Test Method for Water Resistance of Paper, Paperboard, and Other Sheet Materials by the Dry Indicator Method \(Withdrawn 2011\)](#)³

[D1732 Practices for Preparation of Magnesium Alloy Surfaces for Painting](#)

[D1974 Practice for Methods of Closing, Sealing, and Reinforcing Fiberboard Boxes](#)

[D3950 Specification for Strapping, Nonmetallic \(and Joining Methods\)](#)

[D3951 Practice for Commercial Packaging](#)

[D3953 Specification for Strapping, Flat Steel and Seals](#)

[D4727/D4727M Specification for Corrugated and Solid Fiberboard Sheet Stock \(Container Grade\) and Cut Shapes](#)

[D5168 Practice for Fabrication and Closure of Triple-Wall Corrugated Fiberboard Containers](#)

[D5486/D5486M Specification for Pressure-Sensitive Tape for Packaging, Box Closure, and Sealing](#)

[F1667 Specification for Driven Fasteners: Nails, Spikes, and Staples](#)

2.2 ANSI Standard:

[ANSI/AHA A135.4 Basic Hardboard](#)⁴

2.3 Federal Specifications:⁵

[A-A-1249 Paper, Wrapping, Tissue](#)

[A-A-1671 Tape, Gummed \(Paper, Reinforced, Asphalt Laminated\)](#)

[A-A-55057 Panels, Wood/Wood-Based; Construction and Decorative](#)

[PPP-B-566 Box, Folding, Paperboard](#)

[PPP-C-96 Can, Metal, 28 Gage and Lighter](#)

[PPP-D-705 Drum, Shipping and Storage: Steel 16 and 30 Gallon Capacity](#)

[PPP-D-723 Drum, Fiber \(inactive for new design\)](#)

[PPP-D-729 Drum, Shipping and Storage: Steel, 55 Gallon](#)

[PPP-P-704 Pails, Metal: \(Shipping, Steel, 1 through 12, Gallons\)](#)

[PPP-T-495 Tubes, Mailing, and Filing](#)

¹ These practices are under the jurisdiction of ASTM Committee B07 on Light Metals and Alloys and are the direct responsibilities of Subcommittee B07.03 on Aluminum Alloy Wrought Products.

Current edition approved Oct. 15, 2008. Published December 2008. Originally approved in 1979. Last previous edition approved in 2002 as B660–02. DOI: 10.1520/B0660-08.

² For referenced ASTM standards, visit the ASTM website, www.astm.org, or contact ASTM Customer Service at service@astm.org. For *Annual Book of ASTM Standards* volume information, refer to the standard's Document Summary page on the ASTM website.

³ The last approved version of this historical standard is referenced on www.astm.org.

⁴ Available from American National Standards Institute (ANSI), 25 W. 43rd St., 4th Floor, New York, NY 10036, <http://www.ansi.org>.

⁵ Available from Standardization Documents Order Desk, DODSSP, Bldg. 4, Section D, 700 Robbins Ave., Philadelphia, PA 19111-5098, <http://www.dodssp.daps.mil>.

*A Summary of Changes section appears at the end of this standard

2.4 Federal Standards:⁵

APA-PS1 U.S. Product Standard (For Construction and Industrial Plywood)

MIL-STD-3010 Test Procedures for Packaging Materials

2.5 Military Specifications:⁵

MIL-C-11796 Corrosion Preventive Compound, Petrolatum, Hot Application

MIL-DTL-17667 Paper, Wrapping, Chemically Neutral (Non-Corrosive)

MIL-PRF-121 Barrier Materials, Greaseproof, Waterproof, Flexible, Heat-Sealable

MIL-PRF-16173 Corrosion Preventive Compound, Solvent Cutback, Cold Application

MIL-PRF-32033 Lubricating Oil, General Purpose, Preservative (Water Displacing, Low Temperature)

MIL-PRF-7870 Lubricating Oil: General Purpose, Low Temperature

2.6 Military Standard:⁵

MIL-STD-129 Marking for Shipment and Storage

2.7 Other Standards:⁶

Aluminum Standards and Data-Protective Oil for Aluminum

3. Classification

3.1 *Levels of Protection*—The following levels of protection apply equally to preservation and packing.

3.1.1 *Level A*—The degree required for protection against the most severe conditions known or anticipated to be encountered during shipment, multiple rough handling, and intransit storage.

3.1.2 *Commercial Packaging*—The degree required for protection of material during shipment from supplier to user for immediate use or limited storage in a dry, heated storage facility. The methods and materials employed by the supplier to satisfy the requirements of the commercial distribution system to provide protection against corrosion, deterioration, and damage during shipment to a user may be used.

4. Terminology

4.1 Definitions:

4.1.1 *corner protector*—protective material placed under ties to protect edges of a package.

4.1.2 *deckboard*—piece of lumber at right angles to stringers or skids of a pallet to form a bearing surface.

4.1.3 *filler*—piece of material placed in a package to fill void space for the purpose of squaring out the contents.

4.1.4 *framing member*—parts forming the main structure of a crate.

4.1.5 *gross weight*—bare item weight and the weight of all packaging and packing materials.

4.1.6 *header*—member of skid-type base used to join the ends of two or more skids and provide added strength to the base.

4.1.7 *interleaving*—placement of a sheet of protective material between two adjacent pieces of metal.

4.1.8 *net weight*—bare item weight.

4.1.9 *nominal*—referring to lumber size, rough sawn commercial size of soft wood lumber common to the industry.

4.1.10 *splice*—to unite or join the ends of material such as lumber, plywood, or paper overlaid veneer.

4.1.11 *tension tied*—securement applied with mechanical tools.

5. General Requirements

5.1 *Materials, Methods, and Containers*—Materials, methods, and containers shall conform to the requirements of this standard. Those exceeding the requirements may be substituted as negotiated by purchaser and producer or supplier.

5.1.1 Materials not covered by applicable specifications or not specifically described herein shall be of high quality and shall be compatible with and protect the contents.

5.1.2 *Splicing Requirement*—When container members must be spliced to obtain the required length or width, the adjacent edges of the two pieces being spliced shall be butt-jointed as specified in 5.1.2.1 and each piece fastened to the splice board. The fastening shall conform to the requirements specified for construction of the panels being spliced. Nails must be clinched.

5.1.2.1 Splice boards shall be applied to extend on each side of the joint at least two times the width of and the same thickness as the box boards.

5.1.3 The inside dimensions of boxes shall be commensurate with the size of the item.

5.2 Internal Packaging Materials:

5.2.1 *Material Compatibility*—Internal packaging materials shall not adversely affect the contents.

5.2.2 *Blocking and Bracing*—Articles not completely filling the shipping container shall be blocked, braced, fastened, or otherwise secured. Articles having projecting parts that may be broken or may puncture the container shall be rigidly supported, suspended, or otherwise protected. Clearance of at least 1 in. (25.4 mm) shall be provided between projecting parts and the adjacent inside face of the container. Blocking and bracing shall be prevented from coming in direct contact with any unprotected surface of the item by use of suitable cushioning material.

5.3 Handling:

5.3.1 *General*—Containers and pallets in their shipping configuration shall be provided with lifting and hoisting provisions commensurate with their weight, size, and intended mode of transportation to ensure safe and efficient movement.

5.3.2 *Hoisting*—Convenient means shall be provided on all shipping containers (except Fig. 32, Fig. 33, Fig. 34, and Fig. 35) and pallets weighing more than 200 lb (90.72 kg) gross which will permit hoisting by attaching suitable slings at the bottom of the containers and pallets.

5.3.3 *Forklift Truck Compatibility*—Unless otherwise specified herein and except Fig. 32, Fig. 33, Fig. 34, and Fig. 35, boxes, containers, and pallets grossing over 200 lb (90.72 kg)

⁶ Available from Aluminum Association, Inc., 1525 Wilson Blvd., Suite 600, Arlington, VA 22209, <http://www.aluminum.org>.

must be capable of being handled from at least two sides by forklift trucks. For DoD use, standard 40 by 48 in. (1016 by 1219.2 mm) pallets must have four-way forklift entry. Openings shall be a minimum of 3 in. (76.2 mm) high and at least 20 in. (508 mm) apart inside-to-inside, symmetrically about the center of balance. Containers may have a single opening 40 in. (1016 mm) wide or more to provide forklift access.

6.1.1 *Level A*—Detailed requirements for packaging (preservation) of aluminum and magnesium products are listed alphabetically by product in **Table 1**. When Level A is specified, items shall be preserved in accordance with the detailed requirements outlined herein.

6. Detailed Requirements

6.1 *Packaging Preservation*—Packaging shall be Level A, or commercial preservation as follows:

TABLE 1 Packaging (Preservation) and Packing for Level A (Note—For Commercial Packaging, See Section 8)

Product	Preservation (6.1.1)	Packing (Section 7) for Barrier, see Table 4	Maximum ^A Net Weight Per Container, lb (kg) (7.16)
Bar, rod and wire (cold-finished, drawn, extruded, rolled, and forged):			
Coiled, bare	AL-oiled, Mg-Chrome pickled (6.1.1.1-6.1.1.3)	Wrapped coils (Fig. 19). Wrap with one layer of Type IIB barrier.	120 (54.43)
Coiled, covered	none required	Wrapped coils (Fig. 19). Wrap with one layer of Type IIB barrier.	120 (54.43)
Spoiled for military requirements: 5, 10, 15, 20, 30, lb (2.27 kg, 4.54 kg, 6.80 kg, 9.07 kg, 13.61 kg) per spool (other: standard commercial weights)	none required	Wooden boxes (Figs. 1-4). Boxes shall be case-lined with one layer of Type IIA barrier or two layers of Type III barrier.	300 (136.08)
Straight lengths	AL-oiled, Mg-Chrome pickled (6.1.1.1-6.1.1.3)	Wooden boxes (Figs. 5-7). Boxes shall be case-lined with one layer of Type IIA barrier or two layers of Type III barrier.	1000 ^B (453.59)
		Corrugated fiberboard boxes, Class weather-resistant (S6.1) or	300 (136.08)
Blooms and billets	See ingot	Fiber-drums (7.14)	200 (90.72)
	
Bus conductors (cold-finished, drawn, extruded and rolled)	See bar, straight lengths
Cable (bare and covered):			
Size 1/0 and smaller	none required	Wrapped coils (Fig. 19). Wrap with one layer of Type IIB barrier.	(bare) 250 (113.40)
		or	(covered) 200 (90.72)
Size larger than 1/0	none required	Reels (Fig. 23).	(bare) 1250 (566.99)
		Reel (Fig. 23).	(covered) 1000 (453.59)
Casting and forgings, finished.	none required	Wooden boxes (Figs. 1-4) or Style 1 Crate Fig. 16).	2000 (907.18)
		Boxes and crates shall be case lined with one layer of Type IIA barrier or two layers of Type III barrier.	
Castings and forgings, rough	none required	Bare bundles (Fig. 20).	1000 (453.59)
Conduit	See ANSI schedule pipe.

TABLE 1 *Continued*

Product	Preservation (6.1.1)	Packing (Section 7) or Barrier, see Table 4	Maximum ^A Net Weight Per Container, lb (kg) (7.16)
Extruded profiles (metal less than 1 lb per linear foot) ^C	AL-oiled, Mg-Chrome-pickled (6.1.1.1-6.1.1.3)	Wooden boxes (Fig. 5-7). Boxes shall be case lined with one layer of Type IIA barrier or	2000 (907.18)
Fittings (pipe and conduit)	AL-oiled, Mg-Chrome-pickled (6.1.1.1-6.1.1.3)	Corrugated fiberboard boxes, Class weather-resistant (S6.1) or	300 (136.08)
	External threads shall be covered with suitable thread protectors.	Wooden boxes (Figs. 1-4) or Style 1 crate (Fig. 16) dependent upon size of fittings. Boxes and crates shall be case lined with one layer Type IIA barrier.	100 (45.36)
Foil ^{D,E}			
Coiled	Foil shall be wound on aluminum fiber or steel cores. End of coil shall be secured with pressure sensitive tape. Sheared edges shall be protected from flanges and adjacent coils with suitable edge protectors. Each coil, or coils (see 7.10) shall be wrapped with aluminum 0.001 in. (0.0254 mm) thick aluminum foil.	Wooden boxes (Figs. 1-4). Coils shall be suspended by extended cores or wood dowels through the core. Core extension or dowel shall be inserted in wood flanges so that periphery of coil does not contact inner surface of box (Fig. 24). Minimum flange thickness shall be as specified in 7.10.	500 (226.80)
	Foil wrap shall be a conformable wrap completely enclosing the coil or coils and edge protectors on each core or dowel (Fig. 24).	Corrugated fiberboard boxes, Class weather-resistant (S6.1) suspended as above.	300 (136.08)
Flat	none required	Wooden boxes (Figs. 1-4). Contents shall be wrapped with one separate layer of Type IIA barrier. or	500 (226.80)
		Corrugated fiberboard boxes, Class weather-resistant (S6.1)	300 (136.08)
Forgings	See castings	...	
Forging stock	See bar	...	
Impact extrusions	none required	Wooden boxes (Figs. 1-4). Boxes shall be lined with one layer of Type IIA barrier. or	700 (317.51)
		Corrugated fiberboard boxes, Class weather-resistant (S6.1)	300 (136.08)
Ingots:			
500 lb (226.80 kg) per piece and over	none required	Loose	...
30–500 lb (13.61-226.80 kg) per piece	none required	Bare bundles (Fig. 22). Size of bundle straps shall be as shown in Table 7. A minimum of two straps shall be used per bundle.	3500 (1587.57)
Less than 30 lb (13.61 kg) per piece	none required	Pallets (Fig. 21). Size pallet straps shall be as shown in Table 7. or	2500 (1133.98)
		Self-palletized bundle. Interlocking ingots that are self-palletized may be shipped in strapped bundles not over 42 in. (1066.8 mm) high. Bundle shall be strapped with a minimum of one ¾-in. (19.05 mm) steel strap.	1500 (680.39)

TABLE 1 *Continued*

Product	Preservation (6.1.1)	Packing (Section 7) for Barrier, see Table 4	Maximum ^A Net Weight Per Container, lb (kg) (7.16)
Grained and granulated ingot and shot	Product to be packed in wood boxes (Figs. 1-4), shall be packaged in Federal Specification PPP-B-566, boxes, folding, paperboard.	Wooden boxes (Figs. 1-4) or	500 (226.80)
		Federal Specification PPP-P-704 Steel Pails (7.12). Pails shall not be overpacked. or	70 (31.75)
		Federal Specification PPP-D-705 and PPP-D-729 Steel Drums (7.13). Drums shall not be overpacked. or	650 (294.84)
		Federal Specification PPP-D-723 Fiber Drums (7.15). Drums shall not be overpacked.	550 (249.48)
Paste and powder	Product to be packed in wooden boxes (Figs. 1-4) shall be packaged in 1 (0.45), 2 (0.91), or 10 (4.54) lb (kg) friction top can in accordance with Federal Specification PPP-C-96, Type V, Class 2.	Wooden boxes (Figs. 1-4). or	50 (22.68)
		Federal Specification PPP-D-705 or PPP-D-729 Steel Drums (7.13). Drums shall not be overpacked.	600 (272.16)
Plate: ^F			
Flat and tapered	Al see Table 2, Mg see Table 3.	Pallets (Figs. 9-12) with pallet enclosures (Fig. 13, Fig. 14, and Fig. 15). Contents shall be wrapped with one layer of Type IIA barrier or two layers of Type III barrier.	4000 (1814.37)
Circles	Al see Table 2, Mg see Table 3.	Pallets (Figs. 9-12) with pallet enclosures (Fig. 13, Fig. 14, and Fig. 15). Contents shall be wrapped with one layer of Type IIA barrier or two layers of Type III barrier.	4000 (1814.37)
Floor and tread Plate and abrasive Tread plate	none required	Pallets (Figs. 9-12). Secure contents to pallet with minimum two lengthwise and two girthwise straps, size 1¼ by 0.031 in. (31.75 mm by .787 mm)	10 000 (4535.92)
Screw machine stock	See bar	...	
Sheet: ^G			
Flat and tapered	Al see Table 2, Mg see Table 3.	Pallet enclosure (Fig. 15)	4000 (1814.37)
		Contents of box shall be wrapped with two layers of Type IIA barrier or one layer of Type IIA barrier and one layer of Type III barrier.	(Not to exceed 200 sheets)
Over 90 lb (40.82 kg) per piece or over 15 ft (4.572 m) in length	Al see Table 2, Mg see Table 3.	Pallets (Figs. 9-12) with pallet enclosures (Fig. 13 and Fig. 14). Contents shall be wrapped with two layers of Type IIA barrier.	4000 (1814.37)
Coiled	Al-coiled, Mg-Chrome-pickled (6.1.1.1-6.1.1.3)	Pallets (Figs. 9-12) with pallet enclosure (Fig. 14). Contents shall be wrapped with one layer of Type IIA barrier or two layers of Type III barrier.	4000 (1814.37)
Roofing and siding	none required	Pallets (Figs. 9-12) with pallet enclosures (Fig. 13 and Fig. 14). Contents shall be wrapped with one layer of Type IIA barrier.	4000 (1814.37)
Structural profiles (extruded and rolled) ^G			

TABLE 1 Continued

Product	Preservation (6.1.1)	Packing (Section 7) for Barrier, see Table 4	Maximum ^A Net Weight Per Container, lb (kg) (7.16)
Less than 150 lb (68.04 kg) per piece	Al-none required. Mg-Chrome-pickled.	Wooden boxes (Figs. 5-7). Boxes shall be case lined with one layer of Type IIA barrier or two layers of Type III barrier. or	1000 (453.59)
		Corrugated fiberboard boxes, Class weather-resistant (S.1.7.1)	300 (136.08)
150 lb (68.04 kg) per piece and over	Al-none required. Mg-Chrome-pickled.	Loose	...
Tubular products (drawn, extruded, and welded):			
Coiled	Al-oiled, Mg-oiled (6.1.1.1-6.1.1.3). Stagger wound coils shall be tied through the core in two places with twine or pressure sensitive tape. Pancake or level layer would coils shall not be tied.	Style 1 crates (Fig. 16). Crates shall be case lined with one layer of Type IIA barrier.	700 (317.51)
		Straight lengths	300 (136.08)
ANSI schedule pipe	Al-no preservative required. Mg-Chrome pickled (6.1.1.1-6.1.1.3). External threads shall be covered with suitable protectors.	Wooden boxes (Figs. 5-7). Boxes shall be case lined with one layer of Type IIA barrier, or Corrugated fiberboard boxes Class weather-resistant (S6.1). or	800 (362.87)
		Fiber tubes (7.16).	200 (90.72)
		Style 2 and 3 crates (Fig. 17 and 18). Crates shall be case lined with one layer of Type IIA barrier. or	4000 (1814.37)
Construction pipe	Al-no preservative required. Mg-Chrome pickled (6.1.1.1-6.1.1.3).	Fiber tubes (7.16).	200 (90.72)
		Same as for ANSI scheduled pipe above.	See Packing
Welding and brazing rod			
Coiled	none required	Wrapped coils (Fig. 19). Wrap with one layer of Type IIA barrier or two layers of Type III barrier.	120 (54.43)
Straight lengths, 36 in. (914.4 mm)	Package 5 lb (2.27 kg) per fiber tube with metal ends or 10 lb (4.54 kg) per fiberboard carton. 10 fiber tubes or 8 cartons shall be overpacked in a weather-resistant fiberboard carton in accordance with Practice D1974. All corners and seams of boxes, including manufacturer's joint, shall be sealed with Specification D5486/D5486M, Type III or IV, Class 1, minimum 2 in. (50.8 mm) wide tape.	Wooden boxes (Figs. 1-4). Fiberboard boxes shall be overpacked in wooden boxes.	1000 (453.59)

TABLE 1 *Continued*

Product	Preservation (6.1.1)	Packing (Section 7) for Barrier, see Table 4	Maximum ^A Net Weight Per Container, lb (kg) (7.16)
Inert gas welding electrode	1, 5, 10, 12½, 15, or 30 lb (.45 kg, 2.27 kg, 4.54 kg, 5.67 kg, 6.80 kg, or 13.61 kg) spools. Individual spools shall be adequately protected by application of moisture-resistant barrier and packaged single or in multiple in fiberboard boxes Practice D1974 , Type CF, Class weather-resistant.	Fiberboard boxes in accordance with Practice D1974 , Type CF, Class weather-resistant, Grade V3c. All corners and seams of boxes, including manufacturer's joint, shall be sealed with Specification D5486/D5486M , Type III or IV, Class 1, minimum 2 in. (50.8 mm) wide tape. Three ⅝ by 0.015 in. (15.88 by .381 mm) flat steel straps, one lengthwise and two girthwise, shall be applied to each box. Maximum gross weight and dimensions of the box specification shall not be exceeded. or Wooden boxes (Figs. 1-4). Intermediate fiberboard boxes overpacked in wooden boxes, shall be closed in accordance with the closure method prescribed above for the fiberboard shipping in wooden containers.	See Packing 1000 (453.59)

^A Maximum weights specified in this table are for shipments to DoD only.
^B Weight may be increased to 2000 lb (907.18 kg) for large quantities for manufacturing when specified in the contract or order.
^C For metal weighing 1 lb (.45 kg)/linear foot or more, see structural profiles.
^D Foil is sheet metal less than 0.006 in. (.152 mm) thick.
^E Foil for food handling applications shall be preserved and packed as specified in the contract or order.
^F Classification of sheet and plate: Sheet is 0.006 through 0.249 in. (.152 through 6.32 mm) thick; plate is 0.250 in. (6.35 mm) and thicker.
^G For metal weighing less than 1 lb (.45 kg)/linear foot, see extruded profiles.

6.1.1.1 *Cleanliness*—Surfaces shall be commercially clean, and free from loose mill scale, dirt, foreign matter, or corrosion. The presence of residual rolling oil shall not be considered foreign matter.

6.1.1.2 *Preservatives*—Oil used for preservation of aluminum products shall conform to the requirements of Aluminum Standards and Data-Protective Oil for Aluminum, MIL-PRF-32033 or MIL-PRF-7870. Oil used for preservation of magnesium products shall conform to the requirements of MIL-PRF-16173, Grade 2, or MIL-C-11796, Class 3. Chrome pickle treatment of magnesium products shall conform to the requirements of Practices **D1732**.

6.1.1.3 *Application of Preservative Coating*—The application of corrosion-preventive material demands careful attention; compounds shall not be applied to surfaces that show signs of moisture, condensation, frost, dirt, or other contaminants. The maximum corrosion resistance is obtained only by a thorough coating of a contaminant-free surface. It is essential that articles treated are not unduly handled until film is set. Application may be by dipping, brushing, rolling, spraying, or flowing onto the surface.

6.1.1.4 *Interleaving*—The interleaving paper shall fully cover the metal; for manual application, paper shall extend 1 in. (25.4 mm) beyond sides and ends, for machine application, paper may be same size as the metal provided the metal is fully covered.

6.1.1.5 *Wraps*—Application of wraps shall be in accordance with **Table 1**. Products may be machine-wrapped or hand-wrapped.

6.1.2 *Commercial Preservation*—When commercial preservation is specified, items will be given the degree of protection normally employed by the supplier against corrosion, deterioration, and damage during shipment.

6.2 *Material Requirements:*

6.2.1 *Fiberboard*—Fiberboard for boxes and liners shall conform to the requirements of Specification **D4727/D4727M**, class weather-resistant.

6.2.2 *Paper and Barrier Material*—Paper and barrier material shall conform to the requirements of **Table 4**.

6.2.3 *Wood*—The species of wood indicated in **Table 5** and classified into groups as shown shall be used. The groups are set up to include, in any one group, species of woods that have approximately similar characteristics important to box design. These characteristics include density, flexural and compressive strength, stiffness, shock absorption, and nailholding power. When any species of wood is specified, any one or more species in the same group may be used. Groups I and II may be interchanged. Groups III and IV may be interchanged.

6.2.4 *Lumber*—All lumber dimensions used in these practices are nominal sizes except where minimum sizes are specified. At least one surface, which is to be placed on the outside of boxes, crates, or pallet closures, shall be sufficiently smooth to permit legible marking, stenciling, or printing. Pieces shall be cut true to length. The boards shall be free of defects that materially weaken them, expose the contents of the box to damage, or interfere with the prescribed fabrication or nailing.

6.2.5 *Plywood*—Unless otherwise specified, plywood used to fabricate cleated panels shall conform to Federal Specification Product Standard APA-PS1 and Federal Specification A-A-55057, standard interior (Grade C-D) with exterior glue.

6.2.6 *Hardboard*—Unless otherwise specified, hardboard shall be in accordance with ANSI/AHA A135.4. When appropriate, hardboard or other composite boards may be used in lieu of plywood for panel stock provided that they are weather resistant and are so sized that they will perform to the same level as plywood.

TABLE 2 Preservation of Aluminum Sheet and Plate
(See Table 1)

Product	Preservation ^{A,B}
Abrasive tread plate	None required
Flat and tapered sheet and plate, and all circles:	
Clad, all alloys:	None required
Circles less than 12 in. (304.88 mm) in diameter	
Flat, tapered and circles 12 in. (304.88 mm) in diameter and over	Interleaved
Nonclad:	
Circles less than 12 in. (304.88 mm) in diameter	None required
Flat, tapered and circles 12 in. (304.88 mm) in diameter and over:	
Heat-treatable alloys, all tempers ^B	Oiled (6.1.1.1-6.1.1.3) ^C
Non-heat-treatable alloys: ^B	
Annealed	Interleaved (6.1.1.4)
Other than annealed:	
0.060 in. (1.524 mm) thick and over	Interleaved (6.1.1.4)
Less than 0.060 in. (1.524 mm) thick	Oiled (6.1.1.1-6.1.1.3) ^C
Painted, chemical conversion coated, and anodized sheet and plate	Interleaved (6.1.1.4)
Floor and tread plate	None required
Coiled sheet	Oiled (6.1.1.1-6.1.1.3) ^C
Perforated sheet	Oiled (6.1.1.1-6.1.1.3) ^C
Roofing and siding sheet	None required

^A Interleaving paper shall be Type 1 paper (Table 4). For metal 0.090 in. (2.29 mm) thick and less interleaving paper shall be minimum 10-lb basis weight; for metal over 0.090 in. (2.29 mm) thick interleaving paper shall be minimum 15-lb basis weight.

^B Heat-treatable alloys are the 2000, 6000, and 7000 groups. Non-heat-treatable alloys are the 1000, 3000, and 5000 groups.

^C For other than DOD requirements, oil at mill option.

TABLE 3 Preservation of Magnesium Sheet and Plate
(See Table 1)

Product	Preservation ^{A,B}
Flat sheet and plate:	
Less than 0.005 in. (.127 mm) thick	Oiled (6.1.1.1-6.1.1.3) or Oiled and interleaved (6.1.1.1-6.1.1.4) or Chrome-pickled and interleaved
0.005 in. (.127 mm) and thicker	None or Oiled (6.1.1.1-6.1.1.3)

^A Interleaving paper shall be as specified for aluminum sheet and plate (Table 2 Footnote A).

^B Preservation desired must be as specified in the contract or order.

6.2.7 *Nails and Staples*—Nails and staples shall conform to Specification F1667 or equivalent. All unclinchd nails shall be cement-coated or chemically etched, except for Style 18 (spiral-shanked) and ring-shanked nails which are also acceptable.

6.2.8 *Strapping*—Flat steel strapping shall conform to Specification D3953, Type 1, Finish A. Equivalent nonmetallic strapping conforming to Specification D3950 may be used when comparable strength requirements are satisfied.

6.2.9 *Tapes*—Tapes shall conform to the requirements of Federal Specifications A-A-1671 or Specification D5486/D5486M as applicable.

6.3 *Packing*—Packing shall be Level A or commercial packing in accordance with Sections 7 and 8.

NOTE 1—Only one type, class, or size of material shall be packed in a single container.

7. Level A Packing

7.1 *General*—When Level A is specified in the contract or order, items shall be packed in accordance with the requirements in Table 1. When Table 1 provides a choice of several containers for a particular product, any one of the containers may be selected for use, unless specifically prohibited by the contract or order. This section provides requirements applicable to packing procedures and construction details for containers and methods not covered by specification reference.

7.2 *Boxes* (Figs. 1-7)—When required by Table 1, boxes shall be constructed as follows:

7.2.1 *Top and Bottom Panels*—Top and bottom panels shall consist of a complete covering of lumber. Panels for boxes, Figs. 1-5, shall be without cleats. Panels for boxes, Fig. 6 and Fig. 7, shall be with cleats. Thickness of panels shall be in accordance with Table 6.

7.2.2 *Side and End Panels*—Side and end panels shall consist of a complete covering of lumber, unless otherwise specified. Thickness and panels shall be in accordance with Table 6.

7.2.2.1 Panels for boxes, Fig. 1 and Fig. 5, 11½ in. (292.1 mm) or less in depth and not more than 16 ft (4.88 m) long shall be of one-piece construction and without cleats, except that end panels may be two-piece, cross-grain-laminated to obtain the required thickness. Side panels more than 16 ft (4.88 m) long may be of two-piece butt joint and splice construction (5.1.2) without cleats.

7.2.2.2 Panels for boxes, Fig. 2, Fig. 3, Fig. 4, Fig. 6, and Fig. 7, more than 11½ in. (292.1 mm) in depth shall be with cleats, except for side panels for boxes, Fig. 2, Fig. 3, and Fig. 4.

7.2.3 *Cleats*—When required by 7.3.2.1 and 7.3.2.2 cleats shall be in accordance with Table 6. Cleats shall be nailed or stapled.

7.2.3.1 *Positioning of Cleats*—Cleats for end panels, Fig. 2 and Fig. 4, shall be placed across the grain of the panel board coverings and extend to within ⅛ in. (3.175 mm) of the inside surface of the top and bottom panels when the containers are closed. Cleats for end panels, Fig. 3, shall be placed across the grain of the panel board coverings and extend to within ⅛ in. (3.175 mm) of the outside surface of the top and bottom panels when the containers are closed. Cleats for Fig. 6 and Fig. 7 containers shall be set-in not more than 6 in. (152.4 mm) from the container ends and spaced a maximum of 65 in. (1651 mm) apart.

TABLE 4 Minimum Requirements for Paper and Barrier Materials (See Table 1)^A

Type	Tensile Strength in Weaker Direction FTMS 2038	Stretch in Creped Direction FTMS 2038	Contact Corrosivity FTMS 3005	Oil Resistance FTMS 3017	Water Resistance Test Method D779	Military/Federal Specification
I. Interleaving: ^B						
A. 10 lb (4.54 kg), uncreped	1½		No corrosion	No delamination, embrittlement, or disintegration		A-A-1249, Tp II
B. 30 lb (13.61 kg), uncreped	10					MIL-DTL-17667, Tp 1 ^C
II. Exterior and interior						
A. Uncreped ^D	65	...	No corrosion	No penetration for 24 hr min and no delamination, embrittlement, or disintegration	24	
B. Creped ^{EF}	35	20			24	
III. Exterior and interior wrap, non-reinforced						
A. Uncreped	30	...	No corrosion	No penetration for 24 h min and no delamination, embrittlement, or disintegration	24	MIL-PRF-121:
B. Creped	25	15			24	Tp I, Gd A, Cl 1 Tp I, Gd A, Cl 2

^A The minimum requirements listed in Table 4 are based on the results of tests performed in accordance with the test methods outlined in MIL-STD-3010, and Test Method D779.

^B Interleaving paper shall be nonabrasive to aluminum surfaces, and have a hydrogen ion concentration (pH) of between 4.5 and 7.5.

^C Except that spring back and identification requirements shall not apply, that the pH value shall be that shown in Footnote B, and that corrosive properties shall be tested for aluminum and magnesium only.

^D Shall have random dispersed reinforced, or a reinforcement spacing not less than 12 threads per foot (39 threads per meter) in both directions.

^E Shall have random dispersed reinforcement, or a reinforcement spacing not less than 12 threads per foot (39 threads per meter) in the longitudinal direction.

^F Tensile strength shall apply only in the reinforced direction.

TABLE 5 Species of Wood

Group I	Group II	Group III	Group IV
Alder, red	Douglas fir	Ash (except white ash)	Ash (white)
Aspen (popple)	Hemlock		Beech
Basswood	Larch (tamarack)	Elm, soft	Birch
Buckeye	Pine, Southern	Gum, red or black	Cherry
Butternut	yellow	Maple, soft or California	Elm, hard
Cedar	Western larch		Hackberry
Chestnut		Oak, California	Hickory
Cottonwood		Sweetgum	Locust
Cypress		Sycamore	Maple, hard
Fir (<i>Abies sp</i>)		Tupelo	Oak
Magnolia			Pecan
Pine (except Southern yellow)			
Redwood			
Spruce			
Willow			
Yellow poplar			

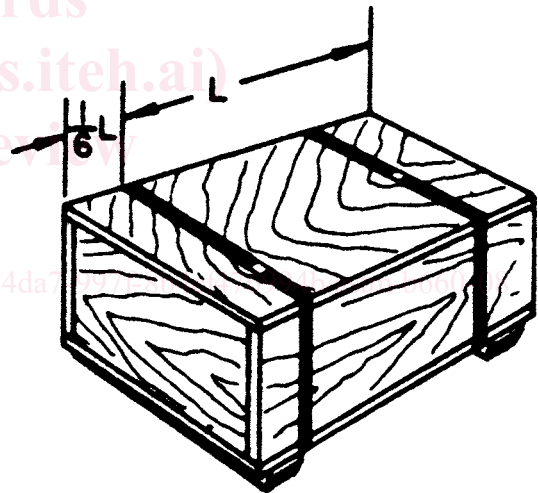

FIG. 1 Style 1 Nail Wood Box^A

7.2.4 *Box Skids*—Boxes with a gross weight of 200 lb (90.72 kg) or over shall be provided with a minimum of two nominal 4 by 4-in. (101.6 by 101.6-mm) skids. As an alternative, skids may be fabricated from two pieces of laminated 2 by 4-in. (50.8 by 101.6 mm) (nominal) lumber. Skids shall replace exterior cleats on box bottom when cleats are required. Skids shall be placed parallel to and extend the full width of the box and shall be positioned not closer than 2½ in. (63.5 mm) nor more than one sixth the length of the box from each end of the box. The distance between skids measured between the inside edges shall not exceed 65 in. (1651 mm). Additional skids, as required, shall be positioned so as to divide the distance between the end skids into units of equal length. The skids shall be notched, as applicable, to provide clearance for strapping. The skids shall be secured to

the box by nails specified in 6.2.7. The nails shall be driven from the inside through the bottom into the skids (in two staggered rows) and shall penetrate a minimum of ¾ (19.05 mm) the thickness of the skids. Nails conforming to Type II, screw-shanked of Specification F1667 or equivalent ring-shanked, shall be of adequate length to penetrate a minimum of ¾ (19.05 mm) the thickness of the skids and shall not protrude through the skids. The bottom half of skid ends may be beveled at an angle of 45°.

7.2.5 *Strapping*—Size of strapping shall not be less than that shown in Table 7.

7.2.5.1 *Strap Spacing*—Straps shall be placed over all girthwise cleats. On boxes without girthwise cleats, Figs. 1-5, girthwise straps shall be set in from each end a distance equal

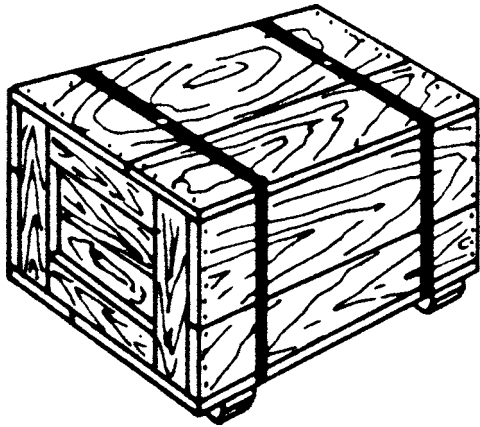

FIG. 2 Style 2 Nail Wood Box^A

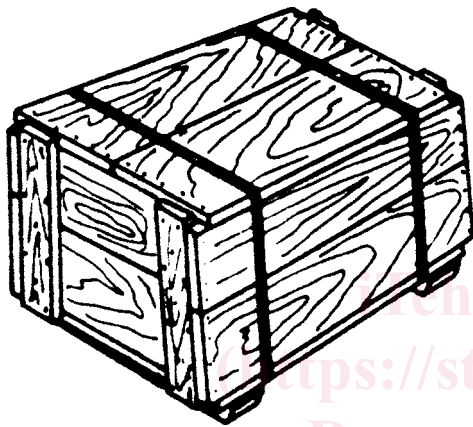

FIG. 3 Style 4 Nail Wood Box^A

Alternate form of cleats

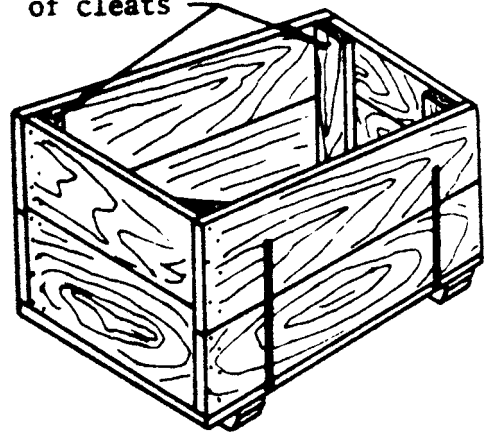

FIG. 4 Style 5 Nail Wood Box^A

- ^A These boxes are for:
- (1) Grained and granulated ingot and shot;
 - (2) Paste and powder;
 - (3) Fittings—(pipe and conduit);
 - (4) Spooled bar, rod, wire;
 - (5) Castings and forgings, finished;
 - (6) Foil, coiled and flat;
 - (7) Impact extrusions;
 - (8) Welding and brazing rod, straight; and
 - (9) Inert gas welding electrodes.

to one sixth the length of the box or 6 in. (152.4 mm), whichever distance is smaller, and spaced at intervals not exceeding 65 in. (1651 mm) (Fig. 5).

7.3 Pallet Construction (see Figs. 8-12):

7.3.1 *Skid Ends (Runner)*, Fig. 8—Skid ends may be cut with a dado or beveled to facilitate sliding skid over an uneven surface. When straps are placed over skids, skids shall be notched out to retain strapping.

7.3.2 *Lengthwise Skids (Runners)*, Fig. 9—For pallets 52 in. (1320.8 mm) wide or less, two skids shall be used and for pallets over 52 in. (1320.8 mm) wide, three skids shall be used. When three skids are required, one skid shall be placed in the center of the pallet. Skids shall be fabricated from nominal 4 by 4-in. (101.6 by 101.6 mm) Group III or IV wood.

7.3.2.1 *Rubbing Strips*—Rubbing strips shall be added to pallets 60 in. (1524 mm) or more in length. Rubbing strips shall be a minimum of 3 in. (76.2 mm) high by 3 in. (76.2 mm) wide, fabricated from laminated 2 by 4 in. (50.8 by 101.6 mm) nominal lumber and shall be attached to the skids in such a manner as to provide four way forklift entry. The bottom half of the rubbing strip shall be beveled at a 45° angle.

7.3.2.2 *Headers*—Headers are optional except for DoD shipments. When required, headers shall be fabricated from nominal 4 by 4 in. (101.6 by 101.6 mm) lumber and shall be bolted to skid ends with ½ by 8 in. (12.7 by 203.2 mm)

carriage bolts. Skids shall be of sufficient length for metal contents to be placed between the headers.

7.3.3 *Crosswise Skids (Runners)*—Fig. 10 illustrates the general arrangement for use on skids perpendicular to the deck boards. The skid dimensions shall be a minimum 3 in. (76.2 mm) high by 3 in. (76.2 mm) wide. Metal less than 5 ft (1.52 m) long may be packed on pallets using crosswise skids.

7.3.4 *Double-Faced Pallets*, (Fig. 11 and Fig. 12)—Skids shall be 3 by 4-in. (76.2 by 101.6 mm) or 2 by 6-in. (50.8 by 152.4 mm) lumber or may be constructed of laminated 1 by 6-in. (25.4 by 152.4 mm) or spliced 2 by 6-in. (50.8 by 152.4 mm) lumber. Joints in spliced 2 by 6-in. (50.8 by 152.4 mm) skids shall be reinforced with 2 by 6-in. (50.8 by 152.4 mm) splice boards, long enough to contact the three stringers as shown in Fig. 12. Stringers shall be minimum 3 by 3 in. (76.2 by 76.2 mm) (and may be fabricated from single piece lumber or laminated lumber of nominal 2 by 4 in. (50.8 by 101.6 mm) and larger. The end stringers shall be placed not more than 1 in. (25.4 mm) from the ends of the skids and deckboards. Additional stringers shall be spaced approximately 42 in. (1066.8 mm) apart on center. Intervals between the last two stringers may vary but shall not exceed 48 in. (1219.2 mm). For plate ½ in. (12.7 mm) thick and over, spacing of stringers may be increased but shall be such as to prevent sagging of metal between stringers. The stringers shall be placed so as not to interfere with center side forklift handling.

7.3.5 *Deckboards*—Deckboards shall be a minimum of 1 by 6-in. (25.4 by 152.4 mm) (nominal) lumber spaced a maximum of 8 in. (203.2 mm) apart. For plate ½ in. (12.7 mm) thick and over, spacing of deckboards shall be such as to prevent sagging of metal between deckboards.