**Ships and marine technology —
General requirements for
inclinometers used for the
determination of trim and list of LNG
carriers**

*Navires et technologie maritime — Exigences générales relatives aux
inclinomètres utilisés pour la détermination de l'assiette et liste des
méthaniers*

(<https://standards.iteh.ai>)
Document Preview

[ISO 19636:2019](https://standards.iteh.ai)

<https://standards.iteh.ai/catalog/standards/iso/1aa39eb0-b614-4319-8462-2d9142c18983/iso-19636-2019>



iTeh Standards
(<https://standards.iteh.ai>)
Document Preview

ISO 19636:2019

<https://standards.iteh.ai/catalog/standards/iso/1aa39eb0-b614-4319-8462-2d9142c18983/iso-19636-2019>



COPYRIGHT PROTECTED DOCUMENT

© ISO 2019

All rights reserved. Unless otherwise specified, or required in the context of its implementation, no part of this publication may be reproduced or utilized otherwise in any form or by any means, electronic or mechanical, including photocopying, or posting on the internet or an intranet, without prior written permission. Permission can be requested from either ISO at the address below or ISO's member body in the country of the requester.

ISO copyright office
CP 401 • Ch. de Blandonnet 8
CH-1214 Vernier, Geneva
Phone: +41 22 749 01 11
Fax: +41 22 749 09 47
Email: copyright@iso.org
Website: www.iso.org

Published in Switzerland

Contents

Page

Foreword	iv
Introduction	v
1 Scope	1
2 Normative references	1
3 Terms and definitions	1
4 Safety precautions	2
4.1 Existing safety regulations, standards and classification societies rules.....	2
4.2 Equipment precautions.....	2
5 Design requirements	3
5.1 General.....	3
5.2 A Trim and list inclinometer's axes and range.....	3
5.3 Communication methods.....	3
5.3.1 Analogue current interface type.....	3
5.3.2 Digital interface type.....	3
5.4 Levelling of a trim and list inclinometer.....	3
5.5 A trim and list inclinometer's protection box.....	4
5.6 Sealing, security and unsealing.....	4
5.7 Marking serial number.....	4
6 Installation	5
6.1 General.....	5
6.2 Installation of a trim and list inclinometer.....	5
6.3 Alignment of a trim and list inclinometer.....	5
6.4 Alignment of a trim and list inclinometer — Ship at dry dock.....	6
6.5 Installation of a trim and list inclinometer — Ship at floating dock.....	6
6.6 Installation of a trim and list inclinometer — Ship anchored or moored.....	7
7 Accuracy	8
7.1 General.....	8
7.2 Uncertainty of a Trim and List inclinometer's inherent error - Factory acceptance test (FAT).....	8
7.3 Uncertainty of reference standard -Site acceptance test (SAT).....	8
7.4 Integrated overall accuracy.....	9
8 Verification test and certification	9
8.1 General.....	9
8.2 Visual examination.....	9
8.3 Verification test.....	10
8.4 Sealing.....	10
8.5 Certificate.....	10
Annex A (informative) Verification of alignment for trim and list inclinometers	11
Bibliography	13

Foreword

ISO (the International Organization for Standardization) is a worldwide federation of national standards bodies (ISO member bodies). The work of preparing International Standards is normally carried out through ISO technical committees. Each member body interested in a subject for which a technical committee has been established has the right to be represented on that committee. International organizations, governmental and non-governmental, in liaison with ISO, also take part in the work. ISO collaborates closely with the International Electrotechnical Commission (IEC) on all matters of electrotechnical standardization.

The procedures used to develop this document and those intended for its further maintenance are described in the ISO/IEC Directives, Part 1. In particular the different approval criteria needed for the different types of ISO documents should be noted. This document was drafted in accordance with the editorial rules of the ISO/IEC Directives, Part 2. www.iso.org/directives

Attention is drawn to the possibility that some of the elements of this document may be the subject of patent rights. ISO shall not be held responsible for identifying any or all such patent rights. Details of any patent rights identified during the development of the document will be in the Introduction and/or on the ISO list of patent declarations received. www.iso.org/patents

Any trade name used in this document is information given for the convenience of users and does not constitute an endorsement.

For an explanation of the voluntary nature of standards, the meaning of ISO specific terms and expressions related to conformity assessment, as well as information about ISO's adherence to the World Trade Organization (WTO) principles in the Technical Barriers to Trade (TBT), see www.iso.org/iso/foreword.html.

This document was prepared by Technical Committee ISO/TC 8, *Ships and marine technology*, Subcommittee SC 8, *Ship design*.

Any feedback or questions on this document should be directed to the user's national standards body. A complete listing of these bodies can be found at www.iso.org/members.html.

<https://standards.iteh.ai/catalog/standards/iso/1aa39eb0-b614-4319-8462-2d9142c18983/iso-19636-2019>

Introduction

Inclinometers are used to determine the trim and list of various types of ships floating on the water. In the case of liquefied natural gas carriers (LNG carriers), on which a large quantity of LNG is traded, based on the results of static measurement, determination of trim and list, along with other elements, is particularly important because the measurement of the liquid level of a cargo tank is inevitably affected by the ship's inclination.

This document provides general requirements for the accuracy, installation, calibration and verification of inclinometers used for the determination of trim and list of LNG carriers, but is not intended to preclude the use or development of any other technologies or methods or the revision of the methods presented. Users of this document are encouraged to review, in detail, the latest editions of the publications, standards and documents referenced in this document in order to gain a better understanding of the methods described.

Users of this document should consider the applicable safety or operating practices recommended by organizations, such as the International Maritime Organization (IMO), the International Chamber of Shipping (ICS), the Oil Companies International Marine Forum (OCIMF), the International Group of LNG Importers (GIIGNL) and the Society of International Gas Tanker and Terminal Operators (SIGTTO), or individual operating companies, as well as any other safety or environmental considerations, local regulations or the specific provisions of any contract.

iTeh Standards
(<https://standards.itih.ai>)
Document Preview

[ISO 19636:2019](https://standards.itih.ai/catalog/standards/iso/1aa39eb0-b614-4319-8462-2d9142c18983/iso-19636-2019)

<https://standards.itih.ai/catalog/standards/iso/1aa39eb0-b614-4319-8462-2d9142c18983/iso-19636-2019>

Ships and marine technology — General requirements for inclinometers used for the determination of trim and list of LNG carriers

1 Scope

This document provides general requirements for the accuracy, installation, calibration and verification of trim and list inclinometers used for the determination of trim and list of LNG carriers for the purpose of measuring on-board cargo level.

2 Normative references

The following documents are referred to in the text in such a way that some or all of their content constitutes requirements of this document. For dated references, only the edition cited applies. For undated references, the latest edition of the referenced document (including any amendments) applies.

IEC 60079-0, *Explosive atmospheres — Part 0: Equipment — General requirements*

3 Terms and definitions

For the purpose of this document, the following terms and definitions apply.

ISO and IEC maintain terminological databases for use in standardization at the following addresses:

- ISO Online browsing platform: available at <http://www.iso.org/obp>
- IEC Electropedia: available at <http://www.electropedia.org/>

3.1

custody transfer measurement system

CTMS

system that processes inputs from an ATG (automatic tank gauge) system, thermometers, pressure gauges, etc., and provides custody transfer measurement information on board, generating documents with regard to custody transfer of LNG

Note 1 to entry: CTMS components include:

- a) automatic level gauge system (radar, microwave, capacitance and float types),
- b) automatic temperature gauge,
- c) automatic pressure gauge,
- d) trim and list indication system

Note 2 to entry: A trim and List inclinometer system can be typically incorporated as part of a CTMS.

Note 3 to entry: See Figure 1.

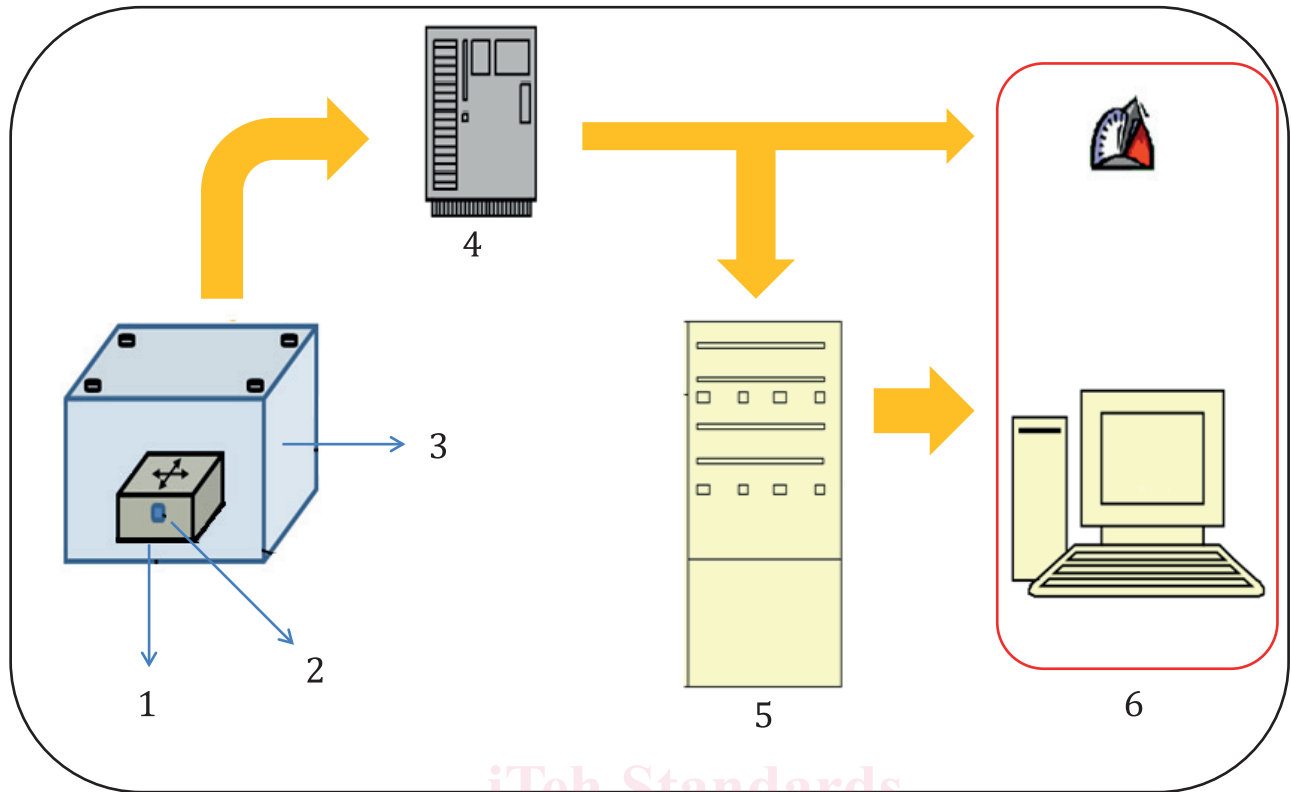

Key

- | | |
|------------------------------|--------------------------------------|
| 1 trim and list inclinometer | 4 connection/control box |
| 2 sensor | 5 custody transfer system (cts) unit |
| 3 protection box | 6 trim and list indicator |

Figure 1 — Outline of trim and list inclinometer system

<https://standards.iteh.ai/catalog/standards/iso/1aa39eb0-b614-4319-8462-2d9142c18983/iso-19636-2019>

3.2 trim and list inclinometer

inclinometer used to determine the trim and list of LNG carriers

3.3 inherent error

error of a trim and list inclinometer when it is tested and verified against a reference standard under controlled conditions as specified by the manufacturer

4 Safety precautions

4.1 Existing safety regulations, standards and classification societies rules

It is the responsibility of the user of this document to consider the applicable safety or operating practices recommended by regulatory agencies and organizations, to establish appropriate health and safety practices and to determine the applicability of regulatory limitations prior to use.

4.2 Equipment precautions

All electric components for the ship’s trim and list inclinometer installed in hazardous areas shall meet the requirements of IEC 60079-0 applicable for the specific zone within the hazardous area. They shall conform to the applicable sections of the national and/or international electrical safety standards

and classification societies rules. Trim and list inclinometers shall be maintained in safe operating conditions in accordance with the manufacturers' instructions.

5 Design requirements

5.1 General

A trim and list inclinometer shall meet the design requirement specified in 5.2 to 5.7.

5.2 A Trim and list inclinometer's axes and range

	List axis (X)	Trim axis (Y)
negative (-) angle	list to port	trim by stern (aft)
positive (+) angle	list to starboard	trim by head (forward)
typical range	-5° to +5°	-2° to +2°

An LNG carrier operates typically within a list of $\pm 1^\circ$ and a trim of ± 3 m. A trim and list inclinometer should be chosen to at least cover the normal operation range but preferably to also cover non-typical situations.

5.3 Communication methods

5.3.1 Analogue current interface type

A trim and list inclinometer shall transmit its output signal as from 4 mA to 20 mA current.

5.3.2 Digital interface type

A trim and list inclinometer is to transmit its output signal as digital protocol as field bus or serial line.

5.4 Levelling of a trim and list inclinometer

It is necessary to be able to make a final adjustment of the levelling for the trim and list inclinometer once it has been installed.

This is typically achieved by placing the sensor on a plate which can be adjusted by screws until it reaches a horizontal position in both axes for the trim and list. See Figure 2.

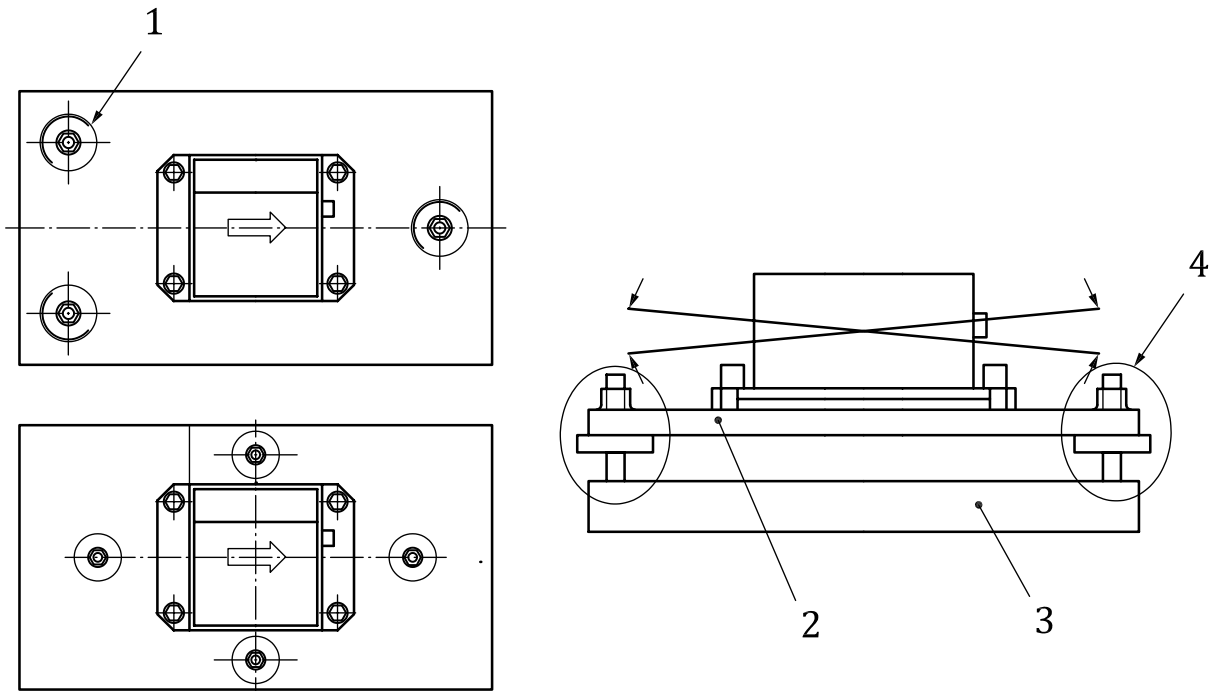

Key

- 1 adjustable screw
- 2 inclinometer's base plate
- 3 hull bottom plate
- 4 adjustable screw or bolt/nut

NOTE The base plate of a trim and list inclinometer is adjustable by adjusting screws or bolts/nuts in two axes.

Figure 2 — Arrangement of 3 or 4 adjustable screws for a Trim and List inclinometer

<https://standards.iteh.ai/catalog/standards/iso/1aa39eb0-b614-4319-8462-2d9142c18983/iso-19636-2019>

5.5 A trim and list inclinometer's protection box

The containment box includes a trim and list inclinometer and all the electrical and mechanical parts necessary for the installation and setup. The box shall be powered by electrical supply voltage and signal communication lines are included.

If the trim and list inclinometer is installed out of safety zones, the trim and list inclinometer and its associated devices, such as intrinsic safety (IS) isolators and anti-pressure explosion for signal, power supply and terminal units, shall be contained in a metal box in order to protect them from damage, heat and shock and to provide security.

5.6 Sealing, security and unsealing

A trim and list inclinometer system shall provide means to prevent unauthorized adjustment or tampering. Specifically, a trim and list inclinometer system used in custody transfer applications shall provide security to allow sealing of the calibration adjustment.

The security may include a physical seal. Once the trim and list inclinometer's protection box has been sealed, it shall not be unsealed until the next scheduled calibration/inspection.

5.7 Marking serial number

The serial number of a trim and list inclinometer shall be clearly marked on the cover of the trim and list inclinometer and on the protection box by the manufacturer.