



Standard Test Method for Determination of Total Sulfur in Light Hydrocarbons, Motor Fuels and Oils by Ultraviolet Fluorescence¹

This standard is issued under the fixed designation D 5453; the number immediately following the designation indicates the year of original adoption or, in the case of revision, the year of last revision. A number in parentheses indicates the year of last reapproval. A superscript epsilon (ϵ) indicates an editorial change since the last revision or reapproval.

^{ε1} NOTE—Footnote 1 was corrected editorially in March 2001.

1. Scope

1.1 This test method covers the determination of total sulfur in liquid hydrocarbons, boiling in the range from approximately 25 to 400°C, with viscosities between approximately 0.2 and 20 cSt (mm²/S) at room temperature.

1.2 Three separate inter-laboratory studies (ILS) on precision have determined that this test method is applicable to naphthas, distillates, oils, and motor fuels: such as gasoline, oxygen enriched gasoline (M-85, RFG), diesel, biodiesel and jet fuel. Samples containing 1.0 to 8000 mg/kg total sulfur can be analyzed (Note 1).

NOTE 1—Estimates of the pooled limit of quantification (PLOQ) for each of the three precision studies were calculated. Values ranged between less than 1.0 and less than 5.0 mg/kg (see Section 8 and 14.1).

1.3 This test method is applicable for total sulfur determination in liquid hydrocarbons containing less than 0.35 % (m/m) halogen(s).

1.4 The values stated in SI units are to be regarded as standard.

1.5 *This standard does not purport to address all of the safety concerns, if any, associated with its use. It is the responsibility of the user of this standard to establish appropriate safety and health practices and determine the applicability of regulatory limitations prior to use.* See 3.1, 6.3, 6.4, 8.1 and Section 7.

2. Referenced Documents

2.1 ASTM Standards:

D 1298 Test Method for Density, Relative Density (Specific Gravity), or API Gravity of Crude Petroleum and Liquid Petroleum Products by Hydrometer Method²

D 4052 Test Method for Density and Relative Density of Liquids by Digital Density Meter³

D 4057 Practice for Manual Sampling of Petroleum and

Petroleum Products³

D 4177 Practice for Automatic Sampling of Petroleum and Petroleum Products³

D 6299 Practice for Applying Statistical Quality Assurance Techniques to Evaluate Analytical Measurement System Performance⁴

3. Summary of Test Method

3.1 A hydrocarbon sample is either directly injected or placed in a sample boat. The sample or boat, or both, is inserted into a high temperature combustion tube where the sulfur is oxidized to sulfur dioxide (SO₂) in an oxygen rich atmosphere. Water produced during the sample combustion is removed and the sample combustion gases are next exposed to ultraviolet (UV) light. The SO₂ absorbs the energy from the UV light and is converted to excited sulfur dioxide (SO₂*). The fluorescence emitted from the excited SO₂* as it returns to a stable state SO₂ is detected by a photomultiplier tube and the resulting signal is a measure of the sulfur contained in the sample. **Warning**—Exposure to excessive quantities of ultraviolet (UV) light is injurious to health. The operator must avoid exposing any part of their person, especially their eyes, not only to direct UV light but also to secondary or scattered radiation that is present.

4. Significance and Use

4.1 Some process catalysts used in petroleum and chemical refining can be poisoned when trace amounts of sulfur bearing materials are contained in the feedstocks. This test method can be used to determine sulfur in process feeds sulfur in finished products, and can also be used for purposes of regulatory control.

5. Apparatus⁵

5.1 **Furnace**—An electric furnace held at a temperature (1075 ± 25°C) sufficient to pyrolyze all of the sample and oxidize sulfur to SO₂.

5.2 **Combustion Tube**—A quartz combustion tube constructed to allow the direct injection of the sample into the

¹ This test method is under the jurisdiction of ASTM Committee D02 on Petroleum Products and Lubricants and is the direct responsibility of Subcommittee D02.030C on Electrometric Methods.

Current edition approved Jan. 10, 2000. Published March 2000. Originally published as D 5453 – 93. Last previous edition D 5453 – 93.

² *Annual Book of ASTM Standards*, Vol 05.01.

³ *Annual Book of ASTM Standards*, Vol 05.02.

⁴ *Annual Book of ASTM Standards*, Vol 05.03.

⁵ Apparatus manufactured in several variations by Antek Instruments, Inc., Houston, TX has been found suitable for this purpose.

heated oxidation zone of the furnace or constructed so that the inlet end of the tube is large enough to accommodate a quartz sample boat. The combustion tube must have side arms for the introduction of oxygen and carrier gas. The oxidation section shall be large enough (see Fig. 1 and Fig. 2) to ensure complete combustion of the sample. Fig. 1 and Fig. 2 depict conventional combustion tubes. Other configurations are acceptable if precision is not degraded.

5.3 *Flow Control*—The apparatus must be equipped with flow controllers capable of maintaining a constant supply of oxygen and carrier gas.

5.4 *Drier Tube*—The apparatus must be equipped with a mechanism for the removal of water vapor. The oxidation reaction produces water vapor which must be eliminated prior to measurement by the detector. This can be accomplished with a membrane drying tube, or a *permeation dryer*, that utilizes a selective capillary action for water removal.

5.5 *UV Fluorescence Detector*—A qualitative and quantitative detector capable of measuring light emitted from the fluorescence of sulfur dioxide by UV light.

5.6 *Microlitre Syringe*—A microlitre syringe capable of accurately delivering 5 to 20- μ L quantities. The needle shall be 50 mm (\pm 5 mm) long.

5.7 *Sample Inlet System*—Either of two types of sample inlet systems can be used.

5.7.1 *Direct Injection*—A direct injection inlet system must be capable of allowing the quantitative delivery of the material to be analyzed into an inlet carrier stream which directs the sample into the oxidation zone at a controlled and repeatable rate. A syringe drive mechanism which discharges the sample from the microlitre syringe at a rate of approximately 1 μ L/s is required. See example, Fig. 3.

5.7.2 *Boat Inlet System*—An extended combustion tube provides a seal to the inlet of the oxidation area and is swept by a carrier gas. The system provides an area to position the sample carrying mechanism (boat) at a retracted position removed from the furnace. The boat drive mechanism will fully insert the boat into the hottest section of the furnace inlet. The sample boats and combustion tube are constructed of

quartz. The combustion tube provides a cooling jacket for the area in which the retracted boat rests awaiting sample introduction from a microlitre syringe. A drive mechanism which advances and withdraws the sample boat into and out of the furnace at a controlled and repeatable rate is required. See example, Fig. 4.

5.8 *Refrigerated Circulator*—An adjustable apparatus capable of delivering a coolant material at a constant temperature as low as 4°C could be required when using the boat inlet injection method (optional).

5.9 *Strip Chart Recorder*, (optional).

5.10 *Balance*, with a precision of \pm 0.01 mg (optional).

6. Reagents

6.1 *Purity of Reagents*—Reagent grade chemicals shall be used in tests. Unless otherwise indicated, it is intended that all reagents shall conform to the specifications of the Committee on Analytical Reagents of the American Chemical Society, where such specifications are available.⁶ Other grades may be used, provided it is first ascertained that the reagent is of sufficiently high purity to permit its use without lessening the accuracy of the determination.

6.2 *Inert Gas*—Argon or helium only, high purity grade (that is, chromatography or zero grade), 99.998 % minimum purity, moisture 5 ppm w/w maximum.

6.3 *Oxygen*—High purity (that is, chromatography or zero grade), 99.75 % minimum purity, moisture 5 ppm w/w maximum, dried over molecular sieves. **Warning**—Vigorously accelerates combustion.

6.4 *Toluene, Xylenes, Isooctane*, reagent grade (other solvents similar to those occurring in samples to be analyzed are also acceptable). Correction for sulfur contribution from solvents (solvent blank) used in standard preparation and sample

⁶ *Reagent Chemicals, American Chemical Society Specifications*, American Chemical Society, Washington, DC. For suggestions on the testing of reagents not listed by the American Chemical Society, see *Analar Standards for Laboratory Chemicals*, BDH Ltd., Poole, Dorset, U.K., and the *United States Pharmacopeia and National Formulary*, U.S. Pharmacopeial Convention, Inc. (USPC), Rockville, MD.

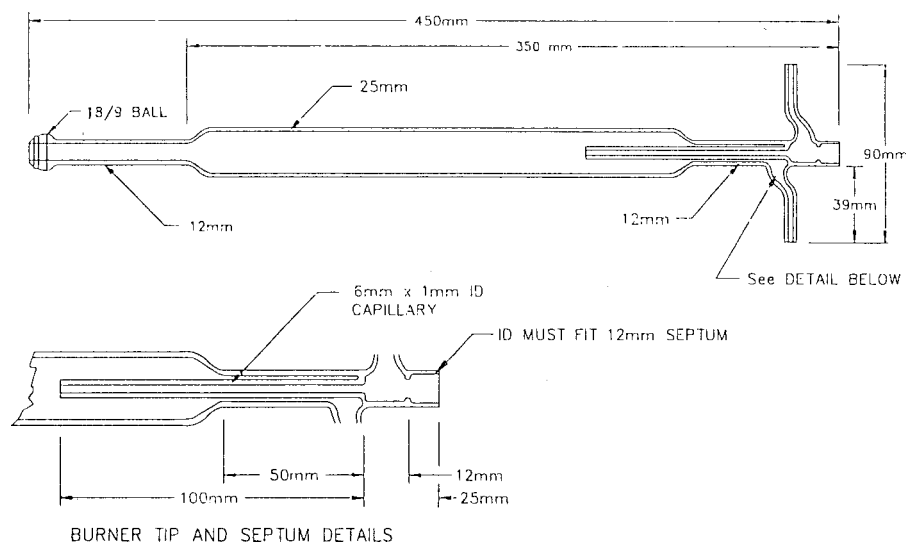

FIG. 1 Direct Inject Quartz Pyrolysis Tube

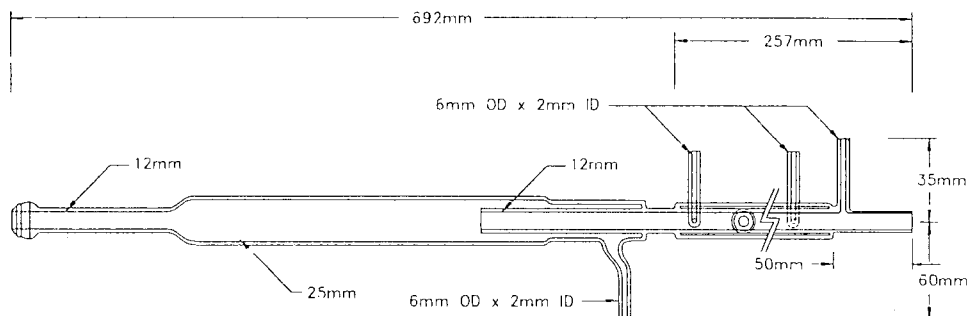

FIG. 2 Boat Inlet

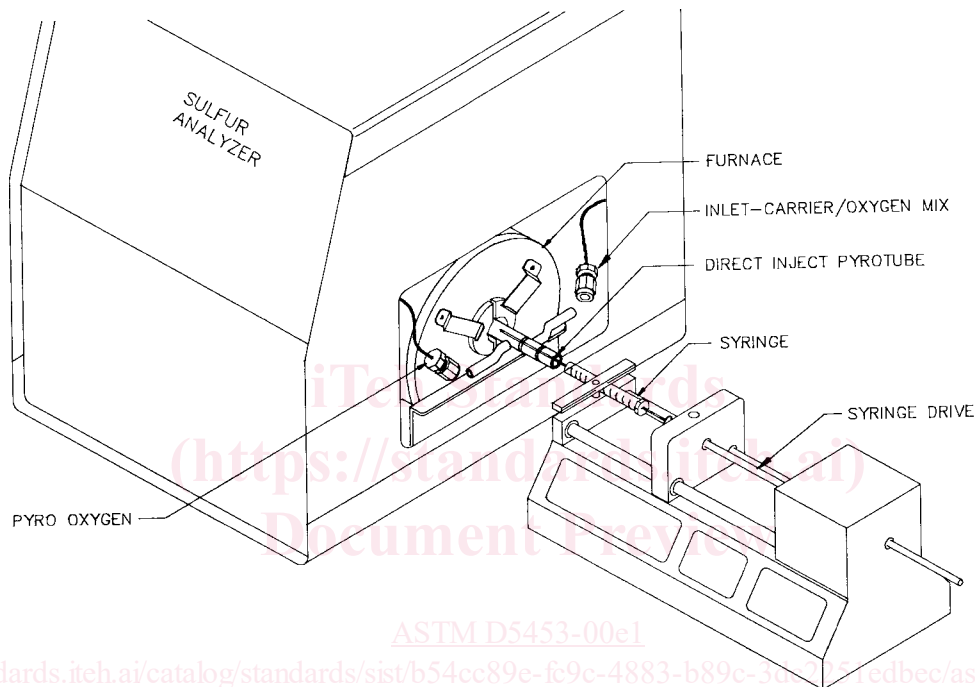

FIG. 3 Direct Inject Syringe Drive

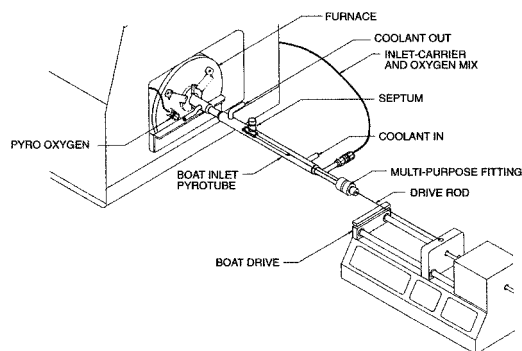

FIG. 4 Boat Inlet System

specimen dilution is required. Alternatively, use of a solvent with nondetectable level of sulfur contamination relative to the sulphur content in the sample unknown makes the blank correction unnecessary. **Warning**—Flammable solvents.

6.5 *Dibenzothiophene*, FW184.26, 17.399 % (m/m) S (Note 2).

6.6 *Butyl Sulfide*, FW146.29, 21.92 % (m/m) S (Note 2).

6.7 *Thionaphthene (Benzothiophene)*, FW134.20, 23.90 % (m/m) S (Note 2).

NOTE 2—A correction for chemical impurity can be required.

6.8 *Quartz Wool*:

6.9 *Sulfur Stock Solution*, 1000 µg S/mL—Prepare a stock solution by accurately weighing approximately 0.5748 g of



dibenzothiophene or 0.4652 g of butyl sulfide or 0.4184 g of thionaphthene into a tared 100 mL volumetric flask. Dilute to volume with selected solvent. This stock can be further diluted to desired sulfur concentration (Notes 3-5).

NOTE 3—Working standards should be remixed on a regular basis depending upon frequency of use and age. Typically, stock solutions have a useful life of about 3 months.

NOTE 4—Calibration standards can be prepared and diluted on a mass/mass basis when result calculations are adjusted to accommodate them.

NOTE 5—Calibration standards from commercial sources can be used if checked for accuracy and if precision is not degraded.

6.10 *Quality Control (QC) Samples*, preferably are portions of one or more liquid petroleum materials that are stable and representative of the samples of interest. These QC samples can be used to check the validity of the testing process as described in Section 13.

7. Hazards

7.1 High temperature is employed in this test method. Extra care must be exercised when using flammable materials near the oxidative pyrolysis furnace.

8. Sampling

8.1 Obtain a test unit in accordance with Practice D 4057 or Practice D 4177. To preserve volatile components which are in some samples, do not uncover samples any longer than necessary. Samples shall be analyzed as soon as possible after taking from bulk supplies to prevent loss of sulfur or contamination due to exposure or contact with sample container. **Warning**—Samples that are collected at temperatures below room temperature can undergo expansion and rupture the container. For such samples, do not fill the container to the top; leave sufficient air space above the sample to allow room for expansion.

8.2 If the test unit is not used immediately, then thoroughly mix in its container prior to taking a test specimen.

9. Preparation of Apparatus

9.1 Assemble and leak check apparatus according to manufacturer's instructions.

9.2 Adjust the apparatus, depending upon the method of sample introduction, to meet conditions described in Table 1.

9.3 Adjust the instrument sensitivity and baseline stability and perform instrument blanking procedures following manufacturer's guidelines.

10. Calibration and Standardization

10.1 Based on anticipated sulfur concentration, select one of the suggested curves outlined in Table 2. Carefully prepare a series of calibration standards accordingly. Make other volu-

TABLE 2 Sulfur Standards

Curve I Sulfur, ng/μL	Curve II Sulfur, ng/μL	Curve III Sulfur, ng/μL
0.50	5.00	100.00
1.00	25.00	500.00
2.50	50.00	1000.00
5.00	100.00	
10.00		
Injection Size 10–20 μL	Injection Size 5–10 μL	Injection Size 5 μL

metric dilutions of the stock solution to cover the various ranges of operation within these calibration curve guidelines. The number of standards used per curve can vary, if equivalent results are obtained.

10.2 Flush the microlitre syringe several times with the sample prior to analysis. If bubbles are present in the liquid column, flush the syringe and withdraw a new sample.

10.3 A sample size recommended for the curve selected from Table 2 must be quantitatively measured prior to injection into the combustion tube or delivery into the sample boat for analysis (Note 6 and Note 7). There are two alternative techniques available.

NOTE 6—Injection of a constant or similar sample size for all materials analyzed in a selected operating range promotes consistent combustion conditions.

NOTE 7—Injection of 10 μL of the 100 ng/μL standard would establish a calibration point equal to 1000 ng or 1.0 μg.

10.3.1 The volumetric measurement of the injected material can be obtained by filling the syringe to the selected level. Retract the plunger so that air is aspirated and the lower liquid meniscus falls on the 10 % scale mark and record the volume of liquid in the syringe. After injection, again retract the plunger so that the lower liquid meniscus falls on the 10 % scale mark and record the volume of liquid in the syringe. The difference between the two volume readings is the volume of sample injected (Note 8).

NOTE 8—An automatic sampling and injection device can be used in place of the described manual injection procedure.

10.3.2 Fill the syringe as described in 10.3.1. Weigh the device before and after injection to determine the amount of sample injected. This procedure can provide greater accuracy than the volume delivery method, provided a balance with a precision of ±0.01 mg is used.

10.4 Once the appropriate sample size has been measured into the microlitre syringe, promptly and quantitatively deliver the sample into the apparatus. Again, there are two alternative techniques available.

10.4.1 For direct injection, carefully insert the syringe into the inlet of the combustion tube and the syringe drive. Allow time for sample residues to be burned from the needle (Needle Blank). Once a stable baseline has reestablished, promptly start the analysis. Remove syringe once the apparatus has returned to a stable baseline.

10.4.2 For the boat inlet, quantitatively discharge the contents of the syringe into the boat containing quartz wool at a slow rate being careful to displace the last drop from the syringe needle. Remove the syringe and promptly start the

TABLE 1 Typical Operating Conditions

Syringe drive (direct inject) drive rate (700–750)	1 μL/s
Boat drive (boat inlet) drive rate (700–750)	140–160 mm/min
Furnace temperature	1075 ± 25°C
Furnace oxygen flowmeter setting (3.8–4.1)	450–500 mL/min
Inlet oxygen flowmeter setting (0.4–0.8)	10–30 mL/min
Inlet carrier flowmeter setting (3.4–3.6)	130–160 mL/min