



SLOVENSKI STANDARD

oSIST prEN 927-3:2018

01-maj-2018

Barve in laki - Premazi in premazni sistemi za zaščito lesa za zunanjo uporabo - 3. del: Preskus s staranjem v naravnih razmerah

Paints and varnishes - Coating materials and coating systems for exterior wood - Part 3: Natural weathering test

Beschichtungsstoffe - Beschichtungsstoffe und Beschichtungssysteme für Holz im Außenbereich - Teil 3: Freibewitterung

Peintures et vernis - Produits de peinture et systèmes de peinture pour bois en extérieur - Partie 3 : Essais de vieillissement naturel

Ta slovenski standard je istoveten z: prEN 927-3

ICS:

71.100.50	Kemikalije za zaščito lesa	Wood-protecting chemicals
87.040	Barve in laki	Paints and varnishes

oSIST prEN 927-3:2018

en,fr,de

EUROPEAN STANDARD
NORME EUROPÉENNE
EUROPÄISCHE NORM

DRAFT
prEN 927-3

April 2018

ICS 87.040

Will supersede EN 927-3:2012

English Version

Paints and varnishes - Coating materials and coating systems for exterior wood - Part 3: Natural weathering test

Peintures et vernis - Produits de peinture et systèmes de peinture pour bois en extérieur - Partie 3 : Essais de vieillissement naturel

Beschichtungsstoffe - Beschichtungsstoffe und Beschichtungssysteme für Holz im Außenbereich - Teil 3: Freibewitterung

This draft European Standard is submitted to CEN members for enquiry. It has been drawn up by the Technical Committee CEN/TC 139.

If this draft becomes a European Standard, CEN members are bound to comply with the CEN/CENELEC Internal Regulations which stipulate the conditions for giving this European Standard the status of a national standard without any alteration.

This draft European Standard was established by CEN in three official versions (English, French, German). A version in any other language made by translation under the responsibility of a CEN member into its own language and notified to the CEN-CENELEC Management Centre has the same status as the official versions.

CEN members are the national standards bodies of Austria, Belgium, Bulgaria, Croatia, Cyprus, Czech Republic, Denmark, Estonia, Finland, Former Yugoslav Republic of Macedonia, France, Germany, Greece, Hungary, Iceland, Ireland, Italy, Latvia, Lithuania, Luxembourg, Malta, Netherlands, Norway, Poland, Portugal, Romania, Serbia, Slovakia, Slovenia, Spain, Sweden, Switzerland, Turkey and United Kingdom.

Recipients of this draft are invited to submit, with their comments, notification of any relevant patent rights of which they are aware and to provide supporting documentation.

Warning : This document is not a European Standard. It is distributed for review and comments. It is subject to change without notice and shall not be referred to as a European Standard.



EUROPEAN COMMITTEE FOR STANDARDIZATION
COMITÉ EUROPÉEN DE NORMALISATION
EUROPÄISCHES KOMITEE FÜR NORMUNG

CEN-CENELEC Management Centre: Rue de la Science 23, B-1040 Brussels

Contents

	Page
European foreword.....	4
1 Scope.....	5
2 Normative references.....	5
3 Terms and definitions.....	6
4 Principle.....	6
5 Apparatus and materials.....	6
6 Coating Sampling.....	7
7 Test panel selection.....	7
8 Procedure.....	10
9 Precision data.....	12
10 Expression of results and test report.....	12
Annex A (normative) Details of test methods.....	13
A.1 Gloss and change of gloss.....	13
A.2 Colour and colour change.....	13
A.3 Blistering.....	13
A.4 Flaking.....	13
A.5 Disfigurement by microorganisms (growth of fungi and algae).....	13
A.6 Cracking.....	14
A.7 Chalking.....	14
A.8 General appearance.....	14
A.9 Adhesion.....	14
A.9.1 General.....	14
A.9.2 Apparatus.....	14
A.9.2.1 Cutting tool.....	14
A.9.2.2 Adhesive tape.....	14
A.9.3 Procedure.....	14
A.10 Test for abnormally porous pine wood.....	14
A.11 Test for heartwood in pine.....	15
Annex B (normative) Assessment requirements for panels of test coatings and WRM.....	16
Annex C (informative) Suggested format for a test report.....	17
Annex D (informative) Optional tests including variations to standard weathering test procedure to obtain additional information on coating performance.....	20
D.1 Principle.....	20
D.2 Tests on alternative wood substrates.....	20
D.3 Tests with water trap.....	20
D.3.1 Apparatus and materials.....	20
D.3.2 Preparation.....	21

D.3.3 Panel assessment	21
D.4 Tests with back sealing of the panels	22
Annex E (informative) Explanatory notes	23
E.1 Natural weathering test	23
E.2 Validity of test reports	23
E.2.1 System	23
E.2.2 Climate and region	23
Annex F (informative) Precision data	24
Annex G (normative) Guidance on typical properties for some common wood species	26
Annex H (informative) Determination of adhesive strength of tape on test surface	30
Annex I (informative) Thermal or chemical modification to protect the wood	31
I.1 General	31
I.2 Thermally modified wood (TMT)	31
I.3 Chemically modified wood (CMT)	31
Bibliography	32

iTeh STANDARD PREVIEW (standards.iteh.ai)

SIST EN 927-3:2019

<https://standards.iteh.ai/catalog/standards/sist/c8020673-5fec-4750-944a-9b130f8a4ee3/sist-en-927-3-2019>

prEN 927-3:2018 (E)

European foreword

This document (prEN 927-3:2018) has been prepared by Technical Committee CEN/TC 139 “Paints and varnishes”, the secretariat of which is held by DIN.

This document is currently submitted to the CEN Enquiry.

This document will supersede EN 927-3:2012.

The main technical changes in comparison with the previous edition are:

- a) the provision for using alternative wood species has been updated;
- b) the Internal Comparison Product (ICP) has been replaced by a nominated Weathering Reference Material (WRM);
- c) mould growth assessment has been extended to disfigurement by microorganisms.

iTeh STANDARD PREVIEW
(standards.iteh.ai)

SIST EN 927-3:2019

<https://standards.iteh.ai/catalog/standards/sist/c8020673-5fec-4750-944a-9b130f8a4ee3/sist-en-927-3-2019>

1 Scope

This document specifies a natural weathering test for exterior wood coating systems mainly intended for decoration and protection of planed and sawn wood.

The test provides a means of evaluating the performance of a wood coating system during outdoor exposure. It forms the basis for the performance specification in accordance with EN 927-2. It also facilitates the comparison of coating systems performance on different substrates including the wood species, or other wood modifications.

2 Normative references

The following documents are referred to in the text in such a way that some or all of their content constitutes requirements of this document. For dated references, only the edition cited applies. For undated references, the latest edition of the referenced document (including any amendments) applies.

EN 927-2, *Paints and varnishes - Coating materials and coating systems for exterior wood - Part 2: Performance specification*

EN ISO 1513, *Paints and varnishes - Examination and preparation of test samples (ISO 1513)*

EN ISO 2409, *Paints and varnishes - Cross-cut test (ISO 2409)*

EN ISO 2808:2007, *Paints and varnishes - Determination of film thickness (ISO 2808:2007)*

EN ISO 2810, *Paints and varnishes - Natural weathering of coatings - Exposure and assessment (ISO 2810)*

EN ISO 2813, *Paints and varnishes - Determination of gloss value at 20°, 60° and 85° (ISO 2813)*

EN ISO 4628-1:2016, *Paints and varnishes - Evaluation of degradation of coatings - Designation of quantity and size of defects, and of intensity of uniform changes in appearance - Part 1: General introduction and designation system (ISO 4628-1:2016)*

EN ISO 4628-2, *Paints and varnishes - Evaluation of degradation of coatings - Designation of quantity and size of defects, and of intensity of uniform changes in appearance - Part 2: Assessment of degree of blistering (ISO 4628-2)*

EN ISO 4628-4, *Paints and varnishes - Evaluation of degradation of coatings - Designation of quantity and size of defects, and of intensity of uniform changes in appearance - Part 4: Assessment of degree of cracking (ISO 4628-4)*

EN ISO 4628-5, *Paints and varnishes - Evaluation of degradation of coatings - Designation of quantity and size of defects, and of intensity of uniform changes in appearance - Part 5: Assessment of degree of flaking (ISO 4628-5)*

EN ISO 4628-6, *Paints and varnishes - Evaluation of degradation of coatings - Designation of quantity and size of defects, and of intensity of uniform changes in appearance - Part 6: Assessment of degree of chalking by tape method (ISO 4628-6)*

EN ISO 15528, *Paints, varnishes and raw materials for paints and varnishes - Sampling (ISO 15528)*

EN ISO 11664-4, *Colorimetry - Part 4: CIE 1976 L*a*b* Colour space (ISO 11664-4)*

ISO 18314-1, *Analytical colorimetry - Part 1: Practical colour measurement*

prEN 927-3:2018 (E)

3 Terms and definitions

No terms and definitions are listed in this document.

ISO and IEC maintain terminological databases for use in standardization at the following addresses:

- IEC Electropedia: available at <http://www.electropedia.org/>
- ISO Online browsing platform: available at <http://www.iso.org/obp>

4 Principle

The resistance to natural weathering of the coating system under test, applied to a specified wood substrate, is assessed. Durability is evaluated by determining the changes in decorative and protective properties of coatings after 12 months of exposure.

The reference test substrate is *Pinus sylvestris* (European redwood or Scots pine, subsequently referred to as pine) in order to obtain comparative results more rapidly. The sapwood, which is usually present in joinery timber, was chosen as the substrate reference instead of heartwood, because paint failure is more evident on the former. However heartwood and other grain orientations may be used as declared alternatives.

Differences in nature and quality of wood, and in the weather and site conditions, are recognized and allowed for in the method by comparing the test system with a nominated 'Weathering Reference Material' (WRM)¹⁾. The WRM is subject to agreement by the customer and test institution and could be a nominated commercial product.

The standard test substrate is pine sapwood. Performance on substrates additional to pine can be carried out using the same test method principles on a nominated substrate (or substrates), e.g. alternative wood species, wood pre-treatments, and wood modifications. The results can be assessed by the criteria of EN 927-2 and subject to meeting them, conformity claimed for the tested substrate/coating combination.

Optional tests are described in Annex D which can provide valuable additional information which may be more relevant to specific circumstances. However to facilitate comparisons the standard requires that pine panels are included as part of each exposure series. An alternative version of the test panel has a machined water-trap. This can accelerate some types of failure.

5 Apparatus and materials

5.1 Exposure racks, inclined at an angle of 45° to the horizontal, on which the specimens are facing towards the equator in accordance with EN ISO 2810.

5.2 Glossmeter, for the measurement of specular gloss in accordance with EN ISO 2813, at 60° geometry.

1) Previous versions of EN 927-3 have used a tightly specified semi-transparent wood stain as the WRM and known as the Internal Comparison Product (ICP). It has proved increasingly difficult to source the raw materials for the ICP and legislation has made some materials unavailable. The ICP was primarily used to assess the severity of the climatic exposure at the weathering site but proved to be relatively insensitive to location. Interpretation of this revised Standard places more emphasis on the absolute test result but allows manufacturers and research organisations to make comparison with tried and tested compositions.

- 5.3 Tristimulus colourimeter or spectrophotometer**, for the measurement of colour and calculation of colour difference in CIELAB colour coordinates in accordance with EN ISO 11664-4.
- 5.4 Tape and cutting tool**, for the assessment of adhesion in accordance with EN ISO 2409.
- 5.5 Microscope**, with a magnification of $\times 10$ for the assessment of surface defects.
- 5.6 Microscope**, for measurement of film thickness in accordance with ISO 2808:2007, method 6A.
- 5.7 Self-adhesive, transparent tape**, in accordance with EN ISO 4628-6 for the assessment of chalking.
- 5.8 Climate chamber**.

6 Coating Sampling

Take a representative sample of the product tested or of each product in the case of a multi-coat system, as described in EN ISO 15528.

Examine and prepare each sample for testing as described in EN ISO 1513.

7 Test panel selection

7.1 Wood reference species

The reference test panel shall be pine that has been selected to be free from knots, cracks and resinous streaks and to be straight-grained and of normal growth rate (i.e. 3 to 8 annual rings per 10 mm). The inclination of the growth rings to the face shall be 5° to 45° (see Figure 1).

The wood shall be free from blue stain and evidence of surface or bulk fungal infection. Abnormal porosity (caused by bacterial attack) shall be avoided (see Annex A, Clause A.10).

The wood shall be conditioned at $(20 \pm 2)^\circ\text{C}$ and a relative humidity of $(65 \pm 5)\%$ to an equilibrium moisture content of $(13 \pm 2)\%$.

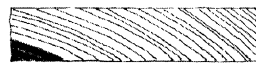

a)



b)



c)



d)

Key

- a) Example of a panel with no heartwood (if present) closer than 10 mm to the test surface fulfilling the requirement for growth ring orientation (5° to 45°) at the front side.
- b) This panel does not meet the specification because the heartwood is too close to the front side.
- c) This panel does not meet the specification because the growth ring orientation is not within the 5° to 45° band. The growth rings incline -10° at the left of the panel and 30° at the right. Consequently a part of the surface contains tangentially cut wood surface (growth ring inclination 0°), with considerable risk of crack formation.
- d) This panel does not meet the specification because the growth ring orientation is not within the 5° to 45° band. The growth rings incline 45° at the left of the panel and 70° at the right.

NOTE The top side of panels is the exposed side; the bottom is the rear face.

Figure 1 — Cross section of panels

7.2 Preparation and selection of wood panels

7.2.1 Reference (standard) test panels

The panels shall be cut from boards planed all round and shall be nominally (375 ± 2) mm \times (78 ± 3) mm and (20 ± 2) mm thick. For details of panel preparation see Figure 2. The panels shall be planed to a smooth and uniform finish. In order to avoid aged wood surface, the panels shall be hand sanded (mesh 150) immediately before coating. Rounding of edges is not permitted.

The panels shall be selected to give a sapwood test surface on the convex side of the growth rings, with any heartwood confined to a zone no closer than 10 mm from the front side. Heartwood shall be checked with the reagent described in A.11, at both ends of each panel.

Any panels showing surface splitting shall be rejected. Where the presence of some minor defects in the test area is unavoidable, their position should be noted and their influence excluded during assessment of coating performance.

7.2.2 Alternative test panels

Alternative substrates including wood species, modified or impregnated wood may be tested according to the requirements of the test specifier (customer). Preparation of the panels should follow the procedure for sizing, planning and sanding as in 7.2.1. However the requirements for heartwood to sapwood ratio and grain orientation may be different. These should be agreed with the user by the testing organization (if different) and the information recorded on the test report. Some guidance on typical properties for some common wood species is given in Annex G.

7.3 Preparation of coated panels

7.3.1 Wood conditioning

Prior to coating, condition the panels at (20 ± 2) °C and a relative humidity of (65 ± 5) % until constant mass. Keep the panels under the same conditions during drying of the coating system and during subsequent storage of test panels before exposure. Panels may be transferred for brief periods to other ambient conditions where this is required for the conduct of specific operations or assessments.

7.3.2 Preparation of panels for the test coating

For each coating system, select four panels on a random basis from the available supply for each species to be tested including the reference. Three panels shall be used for exposure and the fourth shall be for unexposed reference.

Apply the coating system to the front and side faces of each panel. The front side of the panel is the side facing the bark of the tree. The back of the panel and end-grains shall be left uncoated.

Apply the coating system using the method specified by the manufacturer to give a spreading rate corresponding to the mean value (± 20 %) of the manufacturer's recommended spreading rate.

Record the quantity of coating applied to each test panel and subsequently calculate a mean value for the four panels. The values should be stated preferably in l/m^2 or g/m^2 , but may also be expressed as wet film thickness (in micrometres).

7.3.3 Preparation of panels for the Weathering Reference Material (WRM)

Prepare four panels by applying the WRM to the front and side faces of each panel. The back of the panel and end-grains shall be left uncoated. Apply the WRM by applying the coating system according to the instructions and allowing for the necessary number of coats and the drying period between coats. The dry film thickness shall be recorded in μm on pine.

One set of WRM panels exposed at the same time may serve as the comparison for one or more test coatings on the reference substrate. The WRM should also be used on each alternative substrate tested as the comparison for one or more test coatings.

7.3.4 Sealing and ageing

When all the coatings have dried, seal thoroughly the ends of the panels with at least two coats of a flexible, moisture-impermeable white paint, for example, but not limited to, a long-oil alkyd type, and capable of withstanding 2 years of natural exposure without breakdown. The 'sealer' may be applied by brushing or dipping. The sealer shall be applied to the bands marked "a" and "c" at the ends of the panel shown in Figure 2. It is important that the sealer is applied all round, i.e. that front, sides, end grains and rear face of the bands are coated.

After sealing, age the panels for approximately 7 days in the controlled environment at (20 ± 2) °C and a relative humidity of (65 ± 5) %, before carrying out initial panel examinations.

Exposure shall start at the latest 28 days after completion of sealing.

Dimensions in millimetres

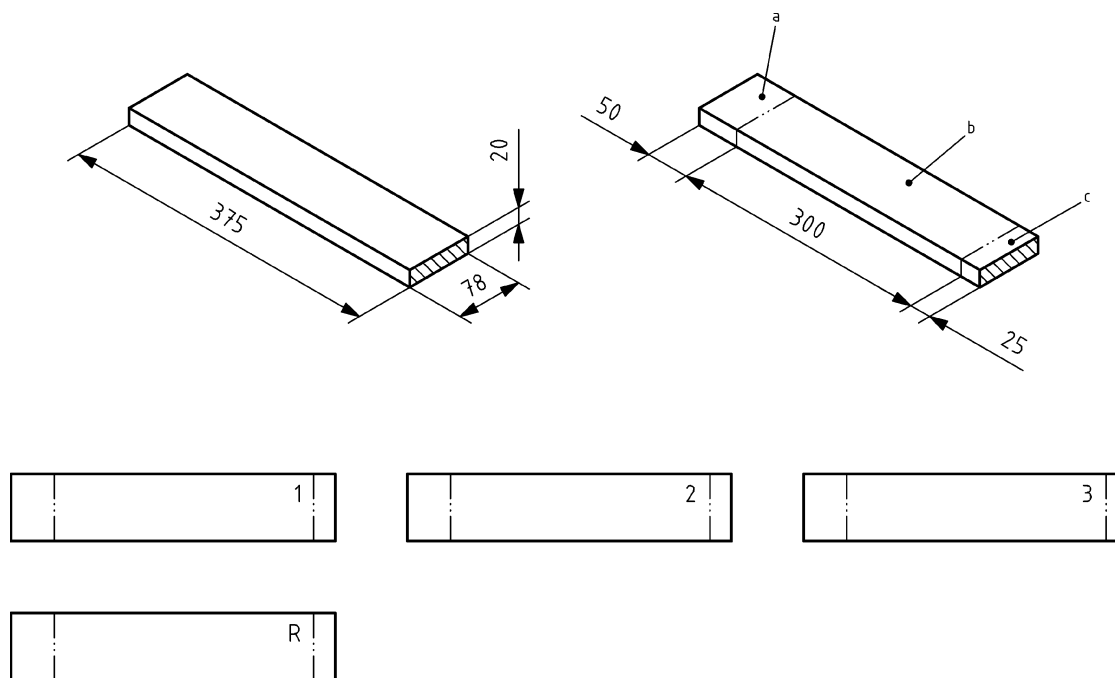
**Key**

- 1, 2 and 3 exposure panels
 R unexposed reference panel
 a sealed end (may be used for numbering of test panels)
 b section for application of coating system
 c sealed end

NOTE The figure is not to scale.

Figure 2 — Details of test panels

7.3.5 Thickness of the coating

Determine the dry film thickness of the WRM and the test coating(s) using the unexposed reference panels. Examine three small chips of coated wood removed from each reference panel by microscopy in accordance with EN ISO 2808:2007, method 6A. The three chips shall be removed at three different places spaced evenly across the panel width. Make five measurements on each of the three chips and calculate and record the mean value in micrometres.

The thickness is stated in micrometres and refers to the layer on (above) the wood surface. Systems may penetrate the wood material to some extent, but this part is not included in the determination.

8 Procedure

8.1 General

Carry out all examinations in accordance with Annex A and Annex B.