**Methods for the calibration of
vibration and shock transducers —
Part 17:
Primary calibration by centrifuge**

*Méthodes pour l'étalonnage des transducteurs de vibrations et de
chocs —*

iTeh STANDARD PREVIEW
Partie 17: Étalonnage primaire par centrifugeur
(standards.iteh.ai)

ISO 16063-17:2016

<https://standards.iteh.ai/catalog/standards/sist/f42bf0dc-38c7-4311-8d6b-93454d146a04/iso-16063-17-2016>



iTeh STANDARD PREVIEW
(standards.iteh.ai)

ISO 16063-17:2016

<https://standards.iteh.ai/catalog/standards/sist/f42bf0dc-38c7-4311-8d6b-93454d146a04/iso-16063-17-2016>



COPYRIGHT PROTECTED DOCUMENT

© ISO 2016, Published in Switzerland

All rights reserved. Unless otherwise specified, no part of this publication may be reproduced or utilized otherwise in any form or by any means, electronic or mechanical, including photocopying, or posting on the internet or an intranet, without prior written permission. Permission can be requested from either ISO at the address below or ISO's member body in the country of the requester.

ISO copyright office
Ch. de Blandonnet 8 • CP 401
CH-1214 Vernier, Geneva, Switzerland
Tel. +41 22 749 01 11
Fax +41 22 749 09 47
copyright@iso.org
www.iso.org

Contents

	Page
Foreword	iv
1 Scope	1
2 Normative references	1
3 Terms and definitions	1
4 Requirements for apparatus and environmental conditions	1
4.1 Calibration environment	1
4.2 Balanced table or arm (rotational table)	1
4.3 Rotational frequency measuring instrumentation	2
4.4 Voltage-measuring instrumentation	3
5 Preferred values	3
6 Method 1 (with measurement of the radius of rotation)	3
6.1 Test procedure	3
6.2 Expression of results	3
7 Method 2 (without measurement of the radius of rotation)	4
7.1 Test procedure	4
7.2 Expression of results	4
Annex A (informative) Expression of uncertainty of measurement in calibration	5
Bibliography	7

iTeh STANDARD PREVIEW
(standards.iteh.ai)

[ISO 16063-17:2016](https://standards.iteh.ai/catalog/standards/sist/f42bf0dc-38c7-4311-8d6b-93454d146a04/iso-16063-17-2016)

<https://standards.iteh.ai/catalog/standards/sist/f42bf0dc-38c7-4311-8d6b-93454d146a04/iso-16063-17-2016>

Foreword

ISO (the International Organization for Standardization) is a worldwide federation of national standards bodies (ISO member bodies). The work of preparing International Standards is normally carried out through ISO technical committees. Each member body interested in a subject for which a technical committee has been established has the right to be represented on that committee. International organizations, governmental and non-governmental, in liaison with ISO, also take part in the work. ISO collaborates closely with the International Electrotechnical Commission (IEC) on all matters of electrotechnical standardization.

The procedures used to develop this document and those intended for its further maintenance are described in the ISO/IEC Directives, Part 1. In particular the different approval criteria needed for the different types of ISO documents should be noted. This document was drafted in accordance with the editorial rules of the ISO/IEC Directives, Part 2 (see www.iso.org/directives).

Attention is drawn to the possibility that some of the elements of this document may be the subject of patent rights. ISO shall not be held responsible for identifying any or all such patent rights. Details of any patent rights identified during the development of the document will be in the Introduction and/or on the ISO list of patent declarations received (see www.iso.org/patents).

Any trade name used in this document is information given for the convenience of users and does not constitute an endorsement.

For an explanation on the meaning of ISO specific terms and expressions related to conformity assessment, as well as information about ISO's adherence to the World Trade Organization (WTO) principles in the Technical Barriers to Trade (TBT) see the following URL: www.iso.org/iso/foreword.html.

The committee responsible for this document is ISO/TC 108, *Mechanical vibration, shock and condition monitoring*, Subcommittee SC 3, *Use and calibration of vibration and shock measuring instruments*.

This first edition of ISO 16063-17 cancels and replaces ISO 5347-7:1993, which has been technically revised.

ISO 16063 consists of the following parts, under the general title *Methods for the calibration of vibration and shock transducers*:

- Part 1: *Basic concepts*
- Part 11: *Primary vibration calibration by laser interferometry*
- Part 12: *Primary vibration calibration by the reciprocity method*
- Part 13: *Primary shock calibration using laser interferometry*
- Part 15: *Primary angular vibration calibration by laser interferometry*
- Part 16: *Calibration by Earth's gravitation*
- Part 17: *Primary calibration by centrifuge*
- Part 21: *Vibration calibration by comparison to a reference transducer*
- Part 22: *Shock calibration by comparison to a reference transducer*
- Part 31: *Testing of transverse vibration sensitivity*
- Part 32: *Resonance testing — Testing the frequency and the phase response of accelerometers by means of shock excitation*
- Part 41: *Calibration of laser vibrometers*
- Part 42: *Calibration of seismometers with high accuracy using acceleration of gravity*

— *Part 43: Calibration of accelerometers by model-based parameter identification*

The following parts are under preparation:

— *Part 33: Testing of magnetic field sensitivity*

iTeh STANDARD PREVIEW
(standards.iteh.ai)

[ISO 16063-17:2016](https://standards.iteh.ai/catalog/standards/sist/f42bf0dc-38c7-4311-8d6b-93454d146a04/iso-16063-17-2016)

<https://standards.iteh.ai/catalog/standards/sist/f42bf0dc-38c7-4311-8d6b-93454d146a04/iso-16063-17-2016>

iTeh STANDARD PREVIEW
(standards.iteh.ai)

ISO 16063-17:2016

<https://standards.iteh.ai/catalog/standards/sist/f42bf0dc-38c7-4311-8d6b-93454d146a04/iso-16063-17-2016>

Methods for the calibration of vibration and shock transducers —

Part 17: Primary calibration by centrifuge

1 Scope

ISO 16063 comprises a series of documents dealing with methods for the calibration of vibration and shock transducers.

This part of ISO 16063 lays down detailed specifications for the instrumentation and procedure to be used for primary calibration of accelerometers using centrifuge calibration.

This part of ISO 16063 is applicable to rectilinear accelerometers with zero-frequency response, mainly of the strain gauge or piezoresistive type, and to primary standard and working transducers.

It is applicable for a calibration range from 10 m/s² to 20 000 m/s² (higher accelerations possible) at 0 Hz.

The limits of uncertainty applicable are $\pm 1\%$ of reading.

2 Normative references

The following documents, in whole or in part, are normatively referenced in this document and are indispensable for its application. For dated references, only the edition cited applies. For undated references, the latest edition of the referenced document (including any amendments) applies.

ISO 2041, *Mechanical vibration, shock and condition monitoring — Vocabulary*

3 Terms and definitions

For the purposes of this document, the terms and definitions given in ISO 2041 apply.

4 Requirements for apparatus and environmental conditions

4.1 Calibration environment

The standard reference atmospheric conditions are: $(23 \pm 3)^\circ\text{C}$ and 75 % relative humidity max. The temperature, humidity and atmospheric pressure shall be measured and reported.

4.2 Balanced table or arm (rotational table)

The main component of the calibration apparatus consists of balanced table or arm which rotates about a vertical axis with uniform angular speed. For the calibration range from 10 m/s² to 100 m/s², the table/arm shall be level within $\pm 0,5^\circ$ of horizontal. For ranges higher than 100 m/s², levelling is allowed to within $\pm 2^\circ$. The calibration apparatus shall be placed on a sufficiently heavy base which is sufficiently isolated from the floor vibration.

The rotational frequency shall be uniform within $\pm 0,05\%$ of the nominal value.

The transducers axis of sensitivity shall be aligned within $\pm 0,5^\circ$.

The radius of rotation to the centre of the transducer mass element shall be measured with an uncertainty less than $\pm 0,15\%$. If this is not possible, Method 2 shall be used (see [Clause 7](#)).

If the accelerometer is substituted by impedances not sensitive to acceleration, the hum and noise when the centrifuge is rotating at the calibration speeds shall be at least 0,5 % below reading.

The apparatus of the main component is illustrated by [Figure 1](#).

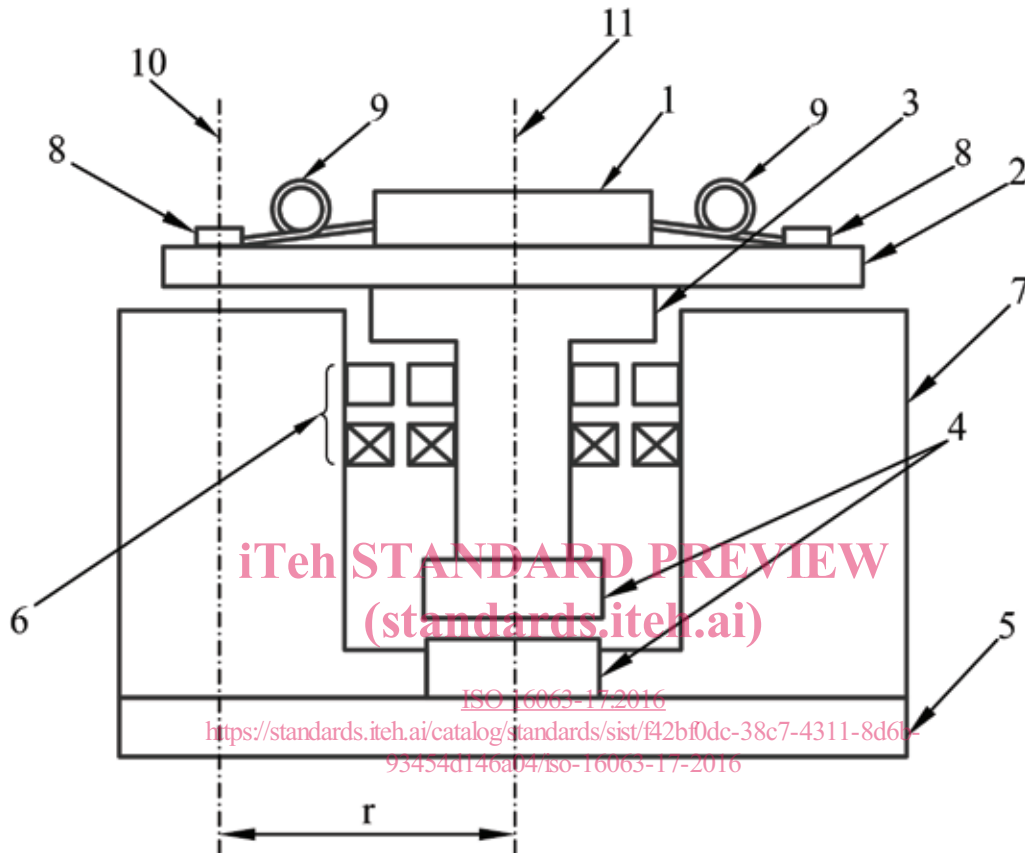

Key

- 1 signal conditioner for transducers
- 2 balanced table
- 3 drive motor
- 4 bearing
- 5 vibration isolation stage
- 6 signal coupler
- 7 stone plate
- 8 transducers
- 9 cable
- 10 centre of mass
- 11 rotation centre

Figure 1 — Illustration of the apparatus of the main component

4.3 Rotational frequency measuring instrumentation

The relative expanded measurement uncertainty ($k = 2$) contribution of the measurement of rotational frequency shall be 0,05 % or less.

4.4 Voltage-measuring instrumentation

The relative expanded measurement uncertainty ($k = 2$) contribution of the voltmeter shall be 0,01 % or less.

5 Preferred values

Six acceleration values, in metres per second squared, equally covering the accelerometer range, shall be chosen from the following series: 10; 20; 50; 100; 200; 500 or their multiples of ten. The reference acceleration shall be 100 m/s² (second choice: 50 m/s²).

6 Method 1 (with measurement of the radius of rotation)

6.1 Test procedure

Rotate the table or arm at different frequencies determined by calculation from the standard levels using [Formula \(1\)](#):

$$a = 4\pi^2 n^2 r \quad (1)$$

where

n is the rotational frequency, in hertz,

r is the radius of rotation to the centre of the accelerometer mass element, in metres.

Measure the transducer output at each rotational frequency.

Determine the reference calibration factor at the reference acceleration. Then, determine the sensitivity for the other calibration amplitudes. The results shall be given as a deviation from the reference calibration factor in percent.

6.2 Expression of results

The calibration factor, S , in volts per (metre per second squared) [V/(m/s²)], is given by [Formula \(2\)](#):

$$S = \frac{V}{4\pi^2 n^2 r} \quad (2)$$

where

V is the transducer output, in volts;

n is the rotational frequency, in hertz;

r is the radius of rotation to the centre of the accelerometer mass element, in metres.

When the calibration results are reported, the total uncertainty of the calibration and the corresponding confidence level, calculated in accordance with [Annex A](#), shall also be reported.