**Road vehicles — Design and
performance specifications for the
WorldSID 50th percentile male side-
impact dummy —**

Part 5:

Dummy design updates

iTeh STANDARD PREVIEW

(standards.iteh.ai)
*Véhicules routiers — Conception et spécifications de performance
pour le mannequin mondial (WorldSID), 50e percentile homme, de
choc latéral —*

ISO/TS 15830-5:2017

<https://standards.iteh.ai/catalog/standards/siv/601800c1-87c9-4119-b7da-8f9e12a41083/iso-ts-15830-5-2017>
Partie 5: Mise à jour de conception applicables

8f9e12a41083/iso-ts-15830-5-2017



iTeh STANDARD PREVIEW
(standards.iteh.ai)

[ISO/TS 15830-5:2017](https://standards.iteh.ai/catalog/standards/sist/66f880e1-86e9-4119-a7da-8f9e12a41083/iso-ts-15830-5-2017)

<https://standards.iteh.ai/catalog/standards/sist/66f880e1-86e9-4119-a7da-8f9e12a41083/iso-ts-15830-5-2017>



COPYRIGHT PROTECTED DOCUMENT

© ISO 2017, Published in Switzerland

All rights reserved. Unless otherwise specified, no part of this publication may be reproduced or utilized otherwise in any form or by any means, electronic or mechanical, including photocopying, or posting on the internet or an intranet, without prior written permission. Permission can be requested from either ISO at the address below or ISO's member body in the country of the requester.

ISO copyright office
Ch. de Blandonnet 8 • CP 401
CH-1214 Vernier, Geneva, Switzerland
Tel. +41 22 749 01 11
Fax +41 22 749 09 47
copyright@iso.org
www.iso.org

Contents

| | Page |
|--|-----------|
| Foreword..... | iv |
| Introduction..... | v |
| 1 Scope..... | 1 |
| 2 Normative references..... | 1 |
| 3 Terms and definitions..... | 1 |
| 4 Mechanical requirements for WorldSID..... | 2 |
| 4.1 Mass properties..... | 2 |
| 4.1.1 Body segment mass specifications..... | 2 |
| 4.1.2 DAS mass..... | 2 |
| 4.2 Permissible DAS mounting locations..... | 3 |
| 4.3 Mechanical modifications..... | 5 |
| 4.3.1 Arm detents..... | 5 |
| 4.3.2 Suit modifications..... | 6 |
| 4.3.3 Ankle design..... | 6 |
| 4.3.4 Pelvis flesh..... | 8 |
| 4.3.5 Neck ring..... | 9 |
| 4.4 Mechanical assembly..... | 9 |
| 5 Sensors..... | 9 |
| 6 Positioning of the WorldSID..... | 9 |
| 7 Certification..... | 9 |
| 8 Whole body dimensions..... | 12 |
| 9 WorldSID design revision dates..... | 14 |
| 10 Temperature measurement..... | 16 |
| Bibliography..... | 17 |

Foreword

ISO (the International Organization for Standardization) is a worldwide federation of national standards bodies (ISO member bodies). The work of preparing International Standards is normally carried out through ISO technical committees. Each member body interested in a subject for which a technical committee has been established has the right to be represented on that committee. International organizations, governmental and non-governmental, in liaison with ISO, also take part in the work. ISO collaborates closely with the International Electrotechnical Commission (IEC) on all matters of electrotechnical standardization.

The procedures used to develop this document and those intended for its further maintenance are described in the ISO/IEC Directives, Part 1. In particular the different approval criteria needed for the different types of ISO documents should be noted. This document was drafted in accordance with the editorial rules of the ISO/IEC Directives, Part 2 (see www.iso.org/directives).

Attention is drawn to the possibility that some of the elements of this document may be the subject of patent rights. ISO shall not be held responsible for identifying any or all such patent rights. Details of any patent rights identified during the development of the document will be in the Introduction and/or on the ISO list of patent declarations received (see www.iso.org/patents).

Any trade name used in this document is information given for the convenience of users and does not constitute an endorsement.

For an explanation on the voluntary nature of standards, the meaning of ISO specific terms and expressions related to conformity assessment, as well as information about ISO's adherence to the World Trade Organization (WTO) principles in the Technical Barriers to Trade (TBT) see the following URL: www.iso.org/iso/foreword.html. (standards.iteh.ai)

This document was prepared by Technical Committee ISO/TC 22, *Road vehicles*, Subcommittee SC 36, *Safety and impact testing*. ISO/TS 15830-5:2017

[https://standards.iteh.ai/catalog/standards/sist/66f880e1-86e9-4119-a7da-](https://standards.iteh.ai/catalog/standards/sist/66f880e1-86e9-4119-a7da-82911d4f8837/iso-ts-15830-5-2017)

A list of all parts in the ISO 15830- series can be found on the ISO website.

Introduction

The purpose of the ISO 15830- series is to document the design and specifications of this side-impact dummy in a form suitable and intended for worldwide regulatory use.

In 1997, ISO/TC 22/SC 12 initiated the WorldSID 50th percentile adult male dummy development, with the aims of defining a global-consensus side-impact dummy, having a wider range of humanlike anthropometry, biofidelity, and injury monitoring capabilities suitable for regulatory use. Participating in the development were research institutes, dummy and instrumentation manufacturers, governments, and vehicle manufacturers from around the world.

With regard to potential regulatory, consumer information, or research and development use of the ISO 15830- series, users will need to identify which of the permissive (i.e. optional) sensors and other elements defined in ISO 15830-3 are to be used in a given application.

WorldSID drawings in electronic format as of June 6, 2004 are available.

This document is intended to document information and design changes which have become available since the publication of the second edition of the ISO 15830- series, (2013-05-15).

In order to apply the ISO 15830- series properly, it is important that all five parts be used together.

iTeh STANDARD PREVIEW (standards.iteh.ai)

[ISO/TS 15830-5:2017](https://standards.iteh.ai/catalog/standards/sist/66f880e1-86e9-4119-a7da-8f9e12a41083/iso-ts-15830-5-2017)

<https://standards.iteh.ai/catalog/standards/sist/66f880e1-86e9-4119-a7da-8f9e12a41083/iso-ts-15830-5-2017>

iTeh STANDARD PREVIEW
(standards.iteh.ai)

[ISO/TS 15830-5:2017](https://standards.iteh.ai/catalog/standards/sist/66f880e1-86e9-4119-a7da-8f9e12a41083/iso-ts-15830-5-2017)

<https://standards.iteh.ai/catalog/standards/sist/66f880e1-86e9-4119-a7da-8f9e12a41083/iso-ts-15830-5-2017>

Road vehicles — Design and performance specifications for the WorldSID 50th percentile male side-impact dummy —

Part 5: Dummy design updates

1 Scope

This document specifies requirements and other design information which became available since 2013 for the WorldSID 50th percentile side-impact dummy, a standardized anthropomorphic dummy for side-impact tests of road vehicles. It is applicable to impact tests involving:

- passenger vehicles of category M₁ and goods vehicles of category N₁;
- impacts to the side of the vehicle structure; and
- impact tests involving use of an anthropomorphic dummy as a human surrogate for the purpose of evaluating compliance with vehicle safety standards.

2 Normative references

The following documents are referred to in the text in such a way that some or all of their content constitutes requirements of this document. For dated references, only the edition cited applies. For undated references, the latest edition of the referenced document (including any amendments) applies.

ISO/TR 27957, *Road vehicles — Temperature measurement in anthropomorphic test devices — Definition of the temperature sensor locations*

3 Terms and definitions

For the purposes of this document, the following terms and definitions apply.

ISO and IEC maintain terminological databases for use in standardization at the following addresses:

- IEC Electropedia: available at <http://www.electropedia.org/>
- ISO Online browsing platform: available at <http://www.iso.org/obp>

3.1

angular rate sensor

ARS

sensor which records angular velocity

3.2

data acquisition system

DAS

system that includes sensors, recorders, cables, and other associated hardware

3.3

H-point tool

device which can be inserted into index holes in the dummy pelvis, which provides an external surface for indicating the orientation of the pelvis and an imaginary line connecting the left and right hip ball joint centres

3.4
infrared telescoping rod for assessment of chest compression
IR-TRACC
 sensor for deflection measurements

4 Mechanical requirements for WorldSID

4.1 Mass properties

4.1.1 Body segment mass specifications

The body segment specifications noted in ISO 15830-2 were based on the parts that are included in specified assembly drawings. For statistical purposes, prior to delivery, actual body segment mass measurements are made, but the split line used between the upper leg and the lumbar spine and pelvis is different than that specified by the assembly drawings. Specifically, the ISO specification included the upper femur and ball socket in the upper leg, whereas the measured masses included these parts in the lumbar spine and pelvis assembly. As a result of the different split lines, some confusion has existed as users compare the measured dummy body segments masses with ISO 15830-2 specifications. In addition, with time, more manufactured dummies have been included in the statistical database, resulting in minor changes to the specified masses. To clarify this situation, Table 1 shows the ISO 15830-2 specifications, updated mass specifications based on recent statistical studies, and updated mass specifications with the alternative split line.

Table 1 — Body segment mass specifications

| Body segment | ISO 15830-2:2013 mass specification kg | 2015 updated specifications kg | 2015 updated specifications with alternative split line kg |
|-----------------------------------|--|--------------------------------------|---|
| Head | 4,22 ± 0,05 | 4,29 ± 0,05 | 4,29 ± 0,05 |
| Neck | 2,84 ± 0,15 | 2,86 ± 0,02 | 2,86 ± 0,02 |
| Thorax/abdomen/shoulder | 20,55 ± 1,0 | 20,56 ± 0,35 | 20,56 ± 0,35 |
| Two full arms | 7,44 ± 0,30 | 7,44 ± 0,30 | 7,44 ± 0,30 |
| Two half arms | 3,54 ± 0,18 | 3,52 ± 0,08 | 3,52 ± 0,08 |
| Lumbar spine and pelvis | 17,75 ± 0,90 | 17,76 ± 0,20 | 19,30 ± 0,20 |
| Two upper legs | 13,42 ± 0,60 | 13,26 ± 0,08 | 11,72 ± 0,08 |
| Two lower legs/ankles/feet | 10,18 ± 0,26 | 10,12 ± 0,14 | 10,12 ± 0,14 |
| Clothing | 1,85 ± 0,09 | 1,54 ± 0,10 | 1,54 ± 0,10 |
| Total with clothing and half arms | 74,35 ± 3,74 | 73,91 ± 1,02 | 73,91 ± 1,02 |

4.1.2 DAS mass

The body segment masses shown in Table 1 include sensors and allocations for DAS components (data recorders, batteries, and other DAS-related components). Each non-load bearing sensor and DAS component shall have a mass replacement and load cells shall have structural replacements which are to be installed any time the actual component is removed from the dummy. Thus, body segment masses shall not change as DAS components are added or removed from various segments. Over time, DAS mass allocations and locations have changed slightly. Table 2 shows DAS mass allocations from 2005, 2013, and the current specifications which reflect actual DAS component masses measured by VRTC.

Table 2 — DAS mass allocation specifications

| Body segment | 2005 kg | 2013 kg | 2015 specification kg |
|------------------|-------------------|-------------------|--------------------------|
| Spine box/thorax | $1,35 \pm 0,300$ | $1,56 \pm 0,350$ | $2,23 \pm 0,30^a$ |
| Pelvis | $0,21 \pm 0,040$ | | $0,22 \pm 0,04$ |
| Left femur | $0,287 \pm 0,060$ | $0,287 \pm 0,060$ | $0,26 \pm 0,06$ |
| Right femur | $0,287 \pm 0,060$ | $0,287 \pm 0,060$ | $0,26 \pm 0,06$ |
| Thorax cabling | $0,075 \pm 0,015$ | $0,075 \pm 0,030$ | $0,08 \pm 0,03$ |
| | | | |
| Total | $2,21 \pm 0,500$ | $2,21 \pm 0,500$ | $3,05 \pm 0,50$ |

^a The spine box DAS mass may be placed inside the spine box, on the non-struck side of spine box, or some combination.

4.2 Permissible DAS mounting locations

Volumes within the thorax, pelvis, and upper leg have been designated as permissible locations for the mounting of various DAS components within the WorldSID. The general locations and basic dimensions of these volumes are shown in Figures 1 to 4.

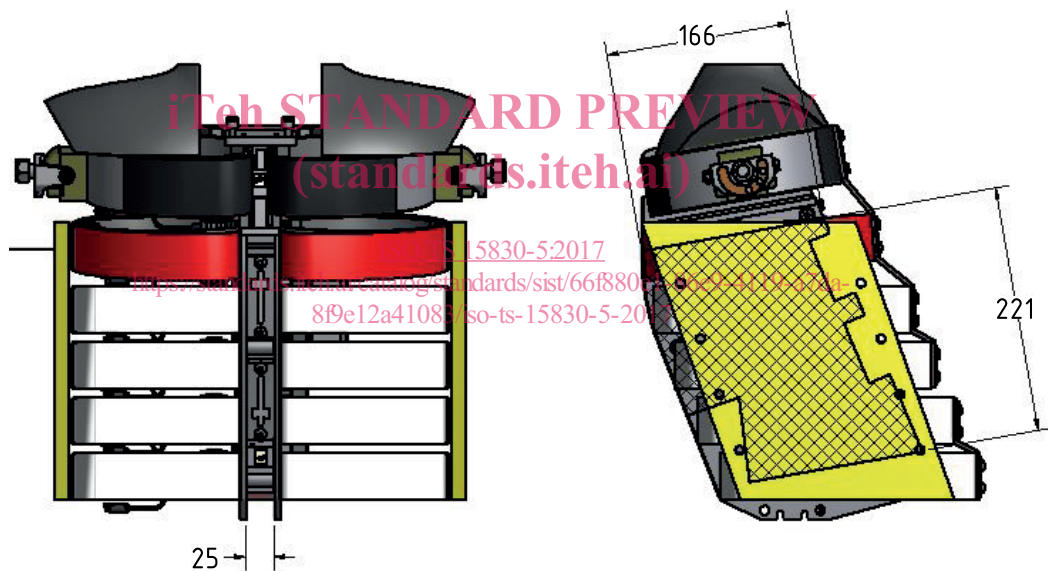

Figure 1 — Spine box volume available for DAS components

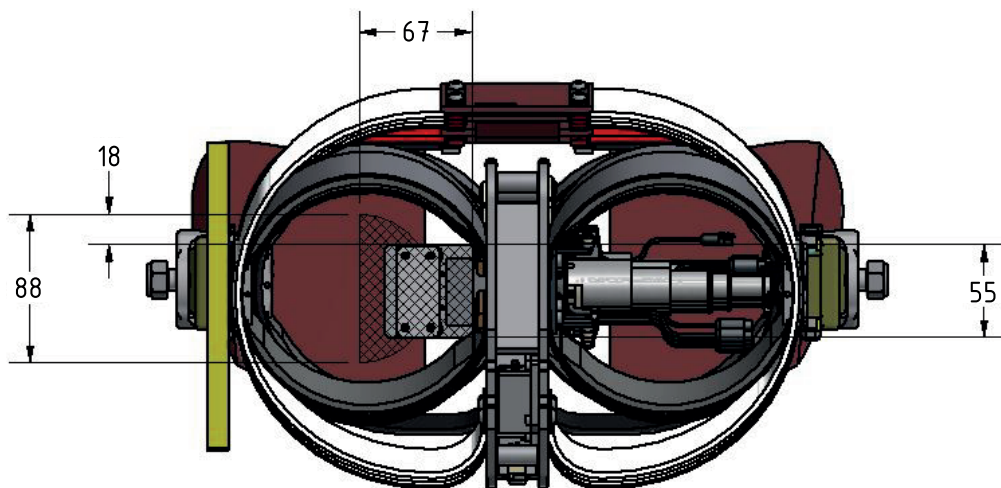

Figure 2 — Non-struck thorax volume available for DAS components

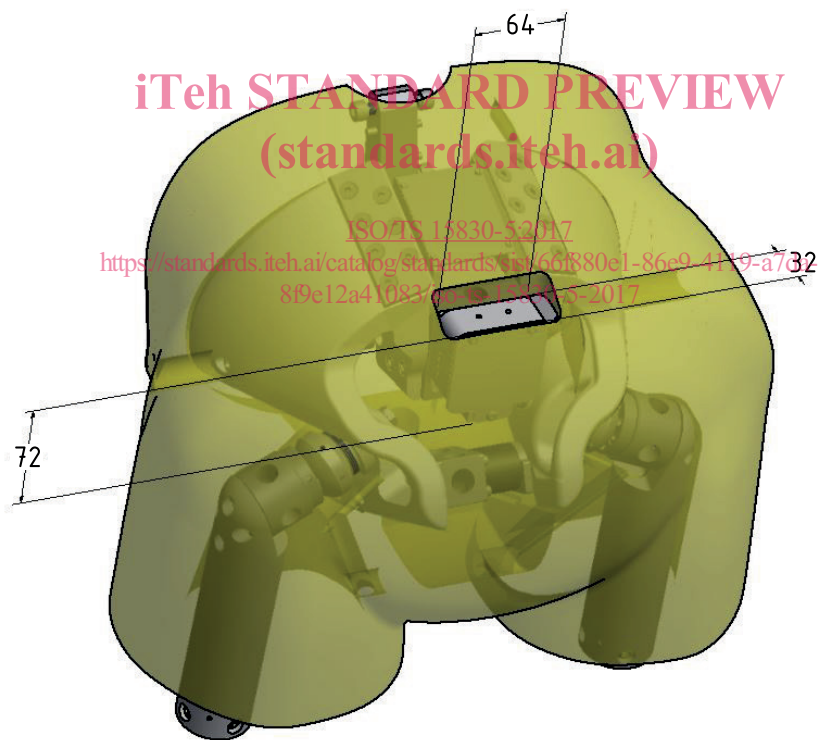

Figure 3 — Pelvis volume available for DAS components

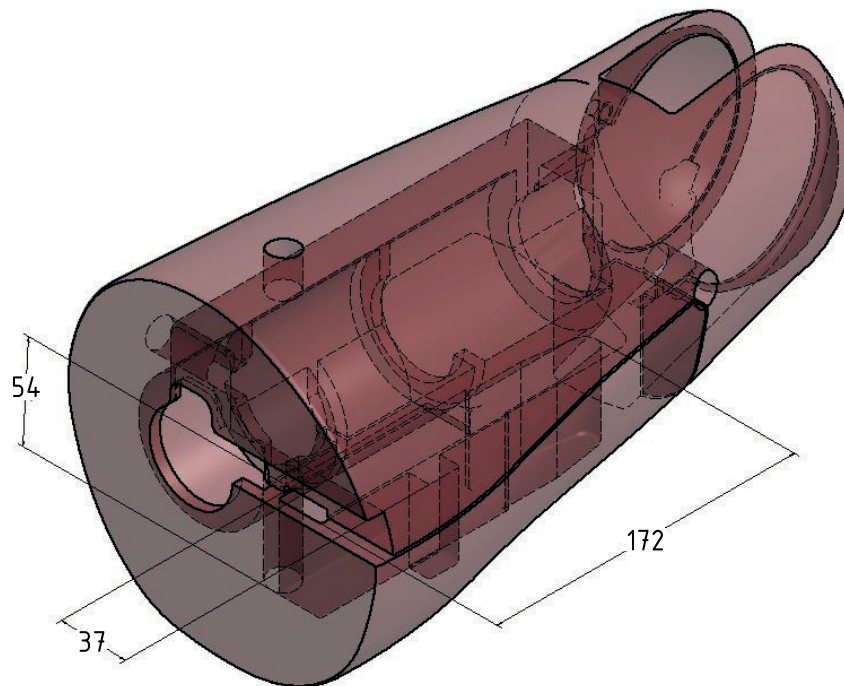

Figure 4 — Upper leg volume available for DAS components

(standards.iteh.ai)

4.3 Mechanical modifications

ISO/TS 15830-5:2017

4.3.1 Arm detents

A system with a spring loaded ball and detents, to help users properly position the arms for testing, exists between the shoulder and upper arm mount fittings. The design was changed in 2015 to facilitate the positioning of the arm in three different positions as shown in Figure 5. The detent position did not change between 2008 and 2015, but the ball detent size and spring tension were increased to better hold the arm at the correct angle during positioning. The extra detent positions that allowed a universal clevis were removed to eliminate confusion of which positions were to be used. The new design requires separate right and left side clevis components.