

# INTERNATIONAL STANDARD

**ISO  
1893**

First edition  
1989-08-01

---

---

## Refractory products — Determination of refractoriness-under-load (differential — with rising temperature)

**iTeh STANDARD PREVIEW**

*Produits réfractaires — Détermination de l'affaissement sous charge (différentiel —  
avec élévation de la température)*  
**(standards.iteh.ai)**

ISO 1893:1989

<https://standards.iteh.ai/catalog/standards/sist/59a16bfe-7967-43a9-b1bc-367229ddc587/iso-1893-1989>



Reference number  
ISO 1893 : 1989 (E)

## Foreword

ISO (the International Organization for Standardization) is a worldwide federation of national standards bodies (ISO member bodies). The work of preparing International Standards is normally carried out through ISO technical committees. Each member body interested in a subject for which a technical committee has been established has the right to be represented on that committee. International organizations, governmental and non-governmental, in liaison with ISO, also take part in the work. ISO collaborates closely with the International Electrotechnical Commission (IEC) on all matters of electrotechnical standardization.

Draft International Standards adopted by the technical committees are circulated to the member bodies for approval before their acceptance as International Standards by the ISO Council. They are approved in accordance with ISO procedures requiring at least 75 % approval by the member bodies voting.

International Standard ISO 1893 was prepared by Technical Committee ISO/TC 33, *Refractories*.

[ISO 1893:1989](#)

<https://standards.iteh.ai/catalog/standards/sist/59a16bfe-7967-43a9-b1bc-507229adc587/iso-1893-1989>

Annex A of this International Standard is for information only.

© ISO 1989

All rights reserved. No part of this publication may be reproduced or utilized in any form or by any means, electronic or mechanical, including photocopying and microfilm, without permission in writing from the publisher.

International Organization for Standardization

Case postale 56 • CH-1211 Genève 20 • Switzerland

Printed in Switzerland

## Introduction

Refractoriness is the property of a material that allows it to withstand high temperature. Refractoriness-under-load is a measure of the resistance of a material to subsidence when it is subjected to a compressive load at elevated temperatures.

No one method of test can objectively measure refractoriness-under-load under all the possible combinations of the many factors involved, which include the duration of exposure. In order to have a single standard test method, certain limitations have to be accepted. The principal of these are, first, that a constant load is applied, secondly, that the temperature is increased at a constant rate, and thirdly, that it is arbitrarily assumed that the value of refractoriness-under-load at any temperature may be represented by the difference between the height of the test piece at that temperature and the maximum value of the height achieved in the rising temperature of the test. The description of the method "with rising temperature" follows from the last of these assumptions, and "differential" from the method of measurement of the height.

It follows that the numerical results of the test are not absolute values of refractoriness-under-load but the test nevertheless provides a useful method of comparing the refractoriness-under-load of different materials.

The test apparatus used in this method of test is the same as that used for the determination of creep in compression, when measurement is made of the deformation with time of a test piece subjected to a constant load at a constant temperature (ISO 3187).

# iTeh STANDARD PREVIEW

(This page intentionally left blank)

ISO 1893:1989

<https://standards.iteh.ai/catalog/standards/sist/59a16bfe-7967-43a9-b1bc-367229ddc587/iso-1893-1989>

# Refractory products — Determination of refractoriness-under-load (differential — with rising temperature)

## 1 Scope

This International Standard specifies a method for determining the deformation of a refractory material or product subjected to a constant load under conditions of progressively rising temperature, or "refractoriness under load" — differential method, with rising temperature. The test may be carried out up to a maximum temperature of 1 700 °C.

## 2 Normative references

The following standards contain provisions which, through reference in this text, constitute provisions of this International Standard. At the time of publication, the editions indicated were valid. All standards are subject to revision, and parties to agreements based on this International Standard are encouraged to investigate the possibility of applying the most recent editions of the standards indicated below. Members of IEC and ISO maintain registers of currently valid International Standards.

ISO/R 836 : 1968, *Vocabulary for the refractories industry*.

ISO 3187 : 1989, *Refractory products — Determination of creep in compression*.

IEC 584-1 : 1977, *Thermocouples — Part 1: Reference tables*.

IEC 584-2 : 1982, *Thermocouples — Part 2: Tolerances*.

## 3 Definitions

For the purposes of this International Standard, the following definitions apply.

**3.1 refractoriness:** The characteristic property of a material of withstanding high temperature.<sup>1)</sup>

**3.2 refractoriness-under-load:** A particular measure of the behaviour of a refractory material subjected to the combined effects of load, rising temperature and time.<sup>1)</sup>

1) These definitions are taken from ISO/R 836.

## 4 Principle

A cylindrical test piece is subjected to a specified constant compressive load and heated at a specified rate of temperature increase until a prescribed deformation or subsidence occurs. The deformation of the test piece is recorded as the temperature increase, and the temperatures corresponding to specified proportional degrees of deformation are determined.

## 5 Apparatus

### 5.1 Loading device

#### 5.1.1 General

The loading device shall be capable of applying a load centred on the common axis of the loading column, the test piece and the supporting column, and directed vertically along this axis at all stages of the test. The loading device consists of the items given in 5.1.2 to 5.1.5.

A constant compressive load is applied in a downward direction from above on the test piece resting directly or indirectly on a fixed base. It follows that the deformation of the test piece is required to be measured by some device that passes either through the applied load or through an intermediate base. For simplicity, the text and figures 1 and 2 in this International Standard show the measuring device passing through the base but, by interchanging the bored column and refractory plate with the unbored column and plate, it may be arranged that the measuring device passes through the load, as in figure 3.

NOTE — Although both arrangements are within the scope of the standard, it is preferable that the measuring device should be positioned below the assembly, as shown in the figures. The reasons for this are outlined in annex A.

**5.1.2 Fixed column,** at least 45 mm in overall diameter and with an axial bore (see 5.1.5).

**5.1.3 Moving column,** at least 45 mm in overall diameter.

NOTE — Arrangements can be made for the upper moving column to be fixed to the furnace, and the combination of furnace and column then forms the moveable loading device.

**5.1.4 Two discs**, 5 mm to 10 mm thick and at least 50 mm in diameter, of an appropriate refractory material compatible with the material under test (e.g., high-fired mullite or alumina for aluminosilicate products, and magnesia or spinel for basic products) which are placed between the test piece and the fixed and moving columns. The disc placed between the test piece and the fixed column shall have a central bore (see 5.1.5). The ends of the fixed and moving columns shall be plane and perpendicular to their axes; the faces of each disc shall be plane and parallel.

NOTE — Platinum or platinum/rhodium sheet (0,2 mm) may be placed between the sample and the discs to prevent chemical reaction, particularly in the case of silica.

**5.1.5** The arrangement of the two columns, the two discs, the platinum sheet if used, and the test piece is shown in figure 2, which also shows typical diameters of the bores in the fixed column and in the disc between them.

**5.1.6** The columns and discs shall be capable of withstanding the applied load up to the final test temperature without significant deformation. There should be no reaction between the discs and the loading system.

**5.2 Furnace** (preferably with a vertical axis), capable of raising the temperature of the test piece to the final test temperature at the specified rate (see 7.4) in an atmosphere of air. The temperature of the region of the furnace occupied by the test piece, when above 500 °C at a stable temperature, shall be uniform around the test piece (12,5 mm above and below) to within  $\pm 20$  K; this shall be verified by carrying out tests using thermocouples located at different points on the curved surface of the test piece.

NOTE — The furnace design should be such that the whole of the column assembly can be easily reached, either by movement of the supporting column or, if access into the furnace is restricted, by movement of the furnace itself. The assembly should be such that the test piece and loading column stand vertically and co-axial with the support column when unrestrained.

**5.3 Measuring device**, consisting of the following items :

**5.3.1 Outer alumina tube**, placed inside the fixed column to abut on the lower side of the lower disc, and free to move within the fixed column (see 5.3.3).

**5.3.2 Inner alumina tube**, placed inside the outer tube and passing through the bores in the lower disc and in the test piece to abut on the lower face of the upper disc, and free to move within the outer tube, the lower disc and the test piece (see 5.3.3).

**5.3.3** The arrangement of the two tubes, the two discs and the test piece as shown in figure 2, which also indicates typical external and internal diameters of the outer and inner tubes.

**5.3.4 Appropriate measuring instrument** (for example a dial-gauge or a length transducer connected to an automatic recording system), fixed to the end of the outer tube (see 5.3.1) and actuated by the inner tube (see 5.3.2). The sensitivity of the measuring device shall be at least 0,005 mm.

**5.3.5** The alumina tubes shall be capable of withstanding the load imposed on them by the measuring instrument at all temperatures up to the final test temperature without significant distortion.

## 5.4 Temperature-measurement devices

**5.4.1 Central thermocouple**, passing through the inner alumina tube (see 5.3.2) of the dilatometer, with its junction at the mid-point of the test piece, for measuring the temperature of the test piece at its geometric centre.

**5.4.2 Control thermocouple**, which shall be placed in a sheath and situated outside the test piece (see figure 1), for regulating the rate of rise of temperature.

NOTE — For certain furnace construction, it may be advisable to place the thermocouple nearer to the heating elements.

**5.4.3** The thermocouples shall be made from platinum and/or platinum-rhodium wire, and shall be compatible with the final test temperature. They shall be in accordance with IEC 584-1 or 584-2.

**5.4.4** The accuracy of the thermocouples shall be checked on a regular basis.

**5.5 Calipers**, to measure to 0,1 mm.

## 6 Test piece

**6.1** The test piece shall be a cylinder 50 mm  $\pm$  0,5 mm in diameter and 50 mm  $\pm$  0,5 mm in height, with a hole from 12 mm to 13 mm in diameter, extending throughout the height of the test piece, bored co-axially with the outer cylindrical surface.

NOTE — The axis of the test piece should preferably be in the direction in which the product was pressed.

**6.2** The top and bottom faces of the test piece shall be made plane and parallel by sawing (and grinding if necessary), and shall be perpendicular to the axis of the cylinder. The surface of the cylinder shall be free from visible defects. Measurements of the height at any two points, using Vernier calipers, shall not differ by more than 0,2 mm. When one face of the test piece is placed on a plane surface and a set square also in contact with the surface is brought into contact with any part of the periphery of the test piece, the gap between the side of the test piece and the square shall not exceed 0,5 mm.

**6.3** To ensure that the top and bottom ends of the test piece are flat over their entire surface, each end shall in turn be pressed onto a levelling plate which is lined with carbon paper and hard filter paper (0,15 mm in thickness). As an alternative to carbon paper, the ends of the test piece may be inked using a stamp pad. Test pieces that do not show two complete, clearly visible coloured impressions shall be re-ground.

NOTE — It is also permissible to control the flatness of the surface with a straightedge.

## 7 Procedure

**7.1** Measure the height of the test piece to 0,1 mm, and measure the inner and outer diameters of the test piece. Set up the test piece between the supporting and loading columns with the spacing discs, and adjust the measuring device to the correct setting. Position the assembly within the furnace.

**7.2** Apply an actual load to the loading column of such magnitude that the preferred stress caused in the test piece (including that due to the mass of the loading column) is as follows :

- a) for dense shaped products : 0,2 N/mm<sup>2</sup>;
- b) for shaped insulating products: 0,05 N/mm<sup>2</sup>,

all stresses being  $\pm 2\%$ . The total load used shall be rounded to the nearest 1 N.

NOTE — Tests for unshaped products are presently outside the scope of this International Standard because there is no standard method for preparing test pieces. However, if such tests are carried out using the method described, the recommended loads are

- a) 0,1 N/mm<sup>2</sup> for dense unshaped products;
- b) 0,05 N/mm<sup>2</sup> for unshaped insulating products.

**7.3** Raise the temperature of the furnace at such a rate that the regulating thermocouple (see 5.4.2) indicates a rate of rise of temperature of between 4,5 K/min and 5,5 K/min.

NOTE — Up to a temperature of 500 °C, a heating rate of up to 10 K/min may be used.

**7.4** Record the temperature at the centre of the test piece and the readings of the measuring device at intervals of not more than 5 min throughout the test. When subsidence commences, take readings of temperature and measurement at intervals of 15 s.

**7.5** Continue heating at a constant rate until the maximum permitted temperature is reached or the subsidence of the test piece exceeds 5 % of its initial height.

## 8 Calculation of results

**8.1** Use the experimental results obtained in accordance with clause 7 to plot the curve  $C_1$  (see figure 4), representing the percentage change in the height of the test piece as a function of temperature, uncorrected for the changes in length of the alumina tubes (5.3.1 and 5.3.2).

**8.2** Ascertain the change in length, as a function of temperature, of a length of the inner alumina tube (5.3.2) equal to the nominal height of the test piece. Express the value of these changes as percentages of the nominal height of the test piece,  $H$ , and with these percentages plot the correction curve  $C_2$  shown in figure 4.

**8.3** Draw the corrected curve  $C_3$ , in which, for any given temperature,  $AB = CD$ .

**8.4** Through the highest point of this corrected curve, draw a straight line parallel to the temperature axis (see figure 4). The deformation  $H$  of the test piece at a given temperature  $t$  is by definition the difference between the ordinate of the straight line and the ordinate of the point on the corrected curve corresponding to temperature  $t$ .

**8.5** Examine the curve to identify the point at which the deformation, measured as in 8.4, corresponds to 0,5 %, 1 %, 2 %, and 5 % of the initial height of the test piece, and note the corresponding temperatures  $t_{0,5}$ ,  $t_1$ ,  $t_2$  and  $t_5$  respectively.

## 9 Test report

The test report shall include the following particulars:

- a) the name of the testing establishment;
- b) the date of the test;
- c) a reference to this International Standard, i.e. "Determination of refractoriness-under-load in accordance with ISO 1893";
- d) the description of the material tested (e.g. manufacturer, type, batch number, etc.);
- e) if applicable, the number of tests performed on each item (brick);
- f) the position and orientation of the test piece in the original brick or shape;
- g) the type of furnace used;
- h) the nature of the atmosphere in the furnace (if other than air);
- i) the heating schedule and the load applied;
- j) the result of the test in accordance with 8.5.

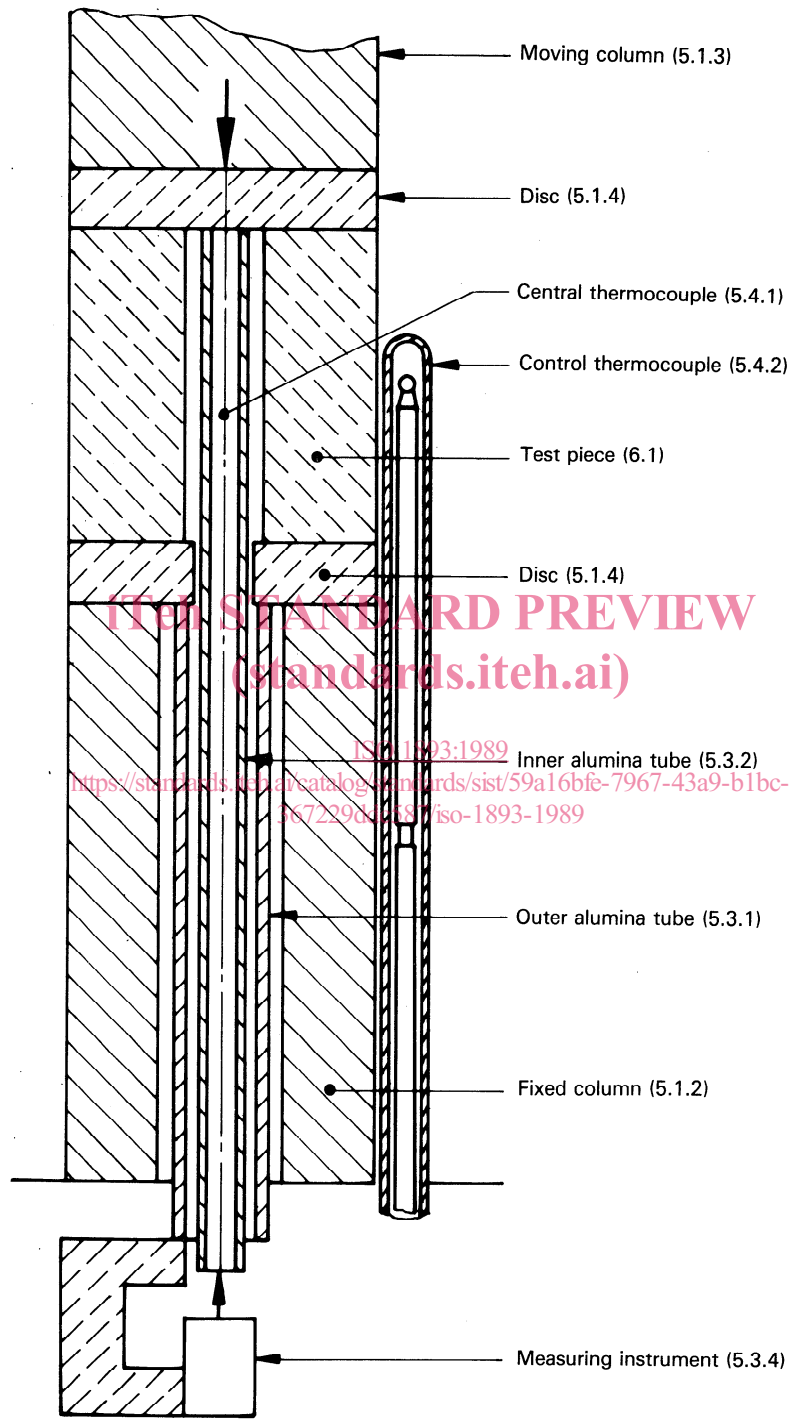

Figure 1 — Test apparatus — Measuring instrument below test piece



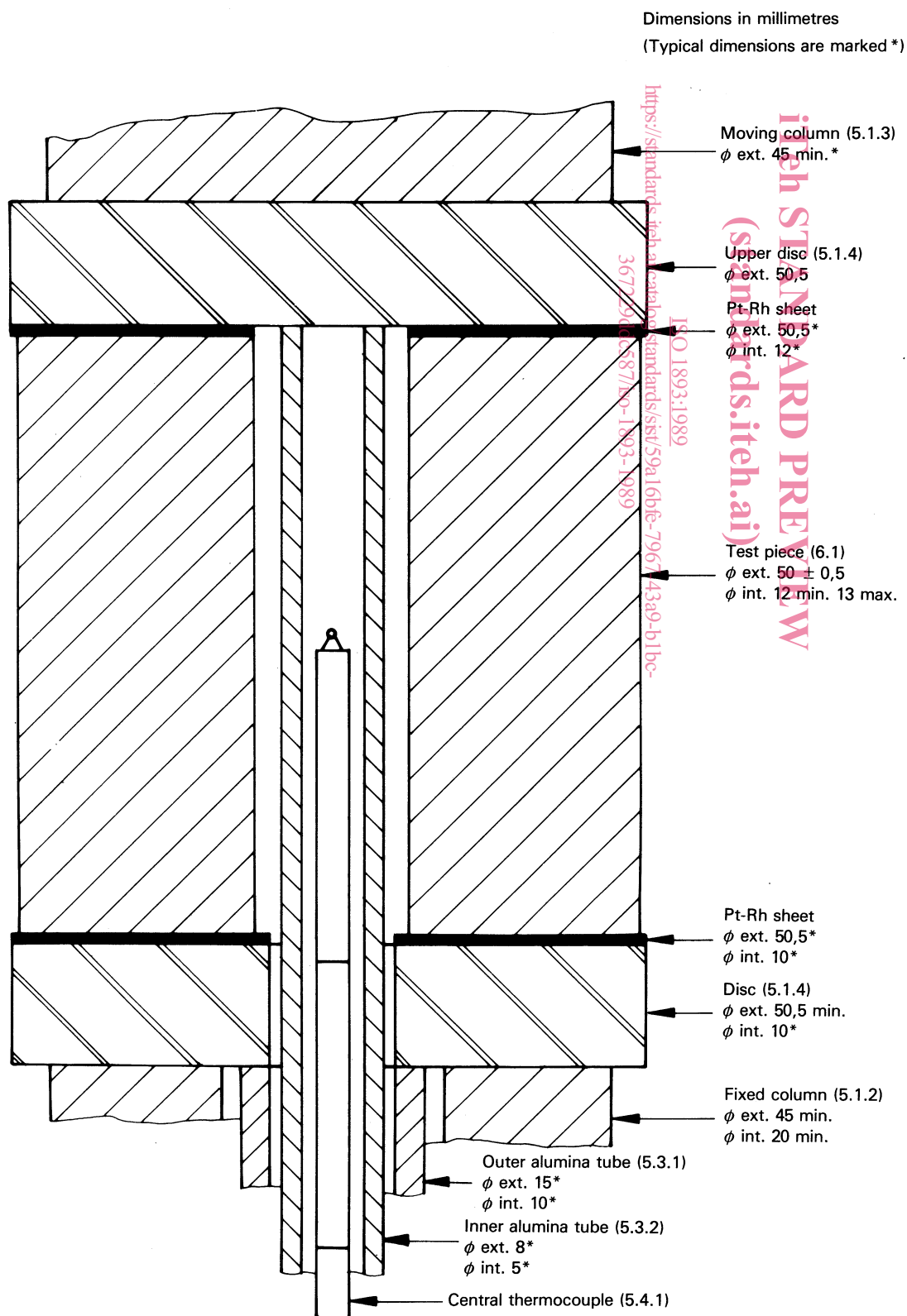

Figure 2 — Preferred arrangement of test piece, columns, discs and tubes