



Standard Specification for Berths, Marine¹

This standard is issued under the fixed designation F 1244; the number immediately following the designation indicates the year of original adoption or, in the case of revision, the year of last revision. A number in parentheses indicates the year of last reapproval. A superscript epsilon (ϵ) indicates an editorial change since the last revision or reapproval.

1. Scope

- 1.1 This specification covers the construction of marine berths for officers, crew, and passengers.
- 1.2 The values stated in inch-pound units are to be regarded as the standard. The values given in parentheses are for information only.

2. Referenced Documents

2.1 ~~ASTM Standards:~~

~~A 366/A 366M Specification for Commercial Steel (CS) Sheet, Carbon, (0.15 Maximum Percent) Cold-Rolled~~ ASTM Standards:²

A 512 Specification for Cold-Drawn Butt Weld Carbon Steel Mechanical Tubing

A 1008/A 1008M Specification for Steel, Sheet, Cold-Rolled, Carbon, Structural, High-Strength Low-Alloy, High-Strength Low-Alloy with Improved Formability, Solution Hardened, and Bake Hardenable

F 825 Specification for Drawers, Furniture, Marine, Steel

F 1085 Specification for Mattress and Box Springs for Use in Berths in Marine Vessels

2.2 *American Institute of Steel Construction Manual:*

³

AISC Wire and Sheet Metal Gages—Equivalent Thicknesses in Decimals of an Inch, U.S. Standard Gage for Uncoated, Hot and Cold Rolled Sheets

3. Terminology

3.1 *Definitions of Terms Specific to This Standard:*

- 3.1.1 *base*—the structure on which the drawer and pan sections are supported and which serves to tie the berth to the deck.
- 3.1.2 *berth*—an item of fixed or built-in furniture for sleeping, with a base and drawer section below the mattress and box spring pan.
- 3.1.3 *berth side rail*—the berth side that runs from head to foot of berth.
- 3.1.4 *box spring*—the resilient box-type support for the mattress covered by fabric.
- 3.1.5 *drawer section*—the section of the berth below the pan section normally designed to contain drawers for stowage of life preservers and other items.
- 3.1.6 *hand*—the berth may be right hand, left hand, or finished both sides for use in the middle of the room. Right hand is defined as follows: the berth is right hand if the head of the berth is on the right hand end when the berth is viewed from the front. Left hand is opposite. See Fig. 1 and Fig. 2 and Table 1 and Table 2 for elevations of left-handed berths. A berth finished on both sides is not shown, but it is one that is accessible from either side, has the head of the berth against a bulkhead, and is not handed.
- 3.1.7 *lee rail*—a guard to inhibit a person from rolling out of bed because of ship motion. In this specification, the lee rail is a raised pine railing.
- 3.1.8 *mattress*—a fabric-covered, box-type unit containing springs and cushioning material that supports the sleeping surface.
- 3.1.9 *pan section*—the section of the berth designed to support the mattress and box spring.

4. Classification

- 4.1 *Type I*—A single berth with pipe, side lee rail with a box spring and mattress pan having inside measurements of 54 in. (1372

¹ This specification is under the jurisdiction of ASTM Committee F25 on Ships and Marine Technology and is the direct responsibility of Subcommittee F25.03 on Outfitting and Deck Machinery.

Current edition approved Nov. 1, ~~2004~~2008. Published November ~~2004~~2008. Originally approved 1989. Last previous edition approved in ~~1999~~2004 as F1244-89 (~~1999~~)F 1244 – 89 (2004).

² For referenced ASTM standards, visit the ASTM website, www.astm.org, or contact ASTM Customer Service at service@astm.org. For *Annual Book of ASTM Standards* volume information, refer to the standard's Document Summary page on the ASTM website.

³ Withdrawn.

³ Available from American Institute of Steel Construction (AISC), One E. Wacker Dr., Suite 700, Chicago, IL 60601-2001, <http://www.aisc.org>.

mm) wide by 80½ in. (2045 mm) long. (See Fig. 1, Table 1, and Note 8 and Note 11 of Fig. 1.)

4.1.1 *Type IA*—Berths conforming generally to the Type I specifications but having special requirements as indicated in the ordering information.

4.2 *Type II*—A single berth with pipe, side lee rail with a box spring and mattress pan having inside measurements of 39 in. (991 mm) wide by 80½ in. (2045 mm) long. (See Fig. 1, Table 1, and Note 8 and Note 11 of Fig. 1.)

4.2.1 *Type IIA*—Berths conforming generally to the Type II specifications but having special requirements as indicated in the ordering information.

4.3 *Type III*—A two-high berth with pipe, side lee rail, the same as Type II, but fitted with an additional pan and uprights to form an upper berth. (See Fig. 2, Table 2, and Note 8, Note 10, and Note 11 of Fig. 1.)

4.3.1 *Type IIIA*—Berths conforming generally to the Type III specifications but having special requirements as indicated in the ordering information.

5. Ordering Information

5.1 Orders for items purchased under this specification shall include the following:

5.1.1 Type of berth.

5.1.1.1 Type I, IA; II, IIA; or III, IIIA.

5.1.1.2 *Hand*—Right, left, or finished both sides.

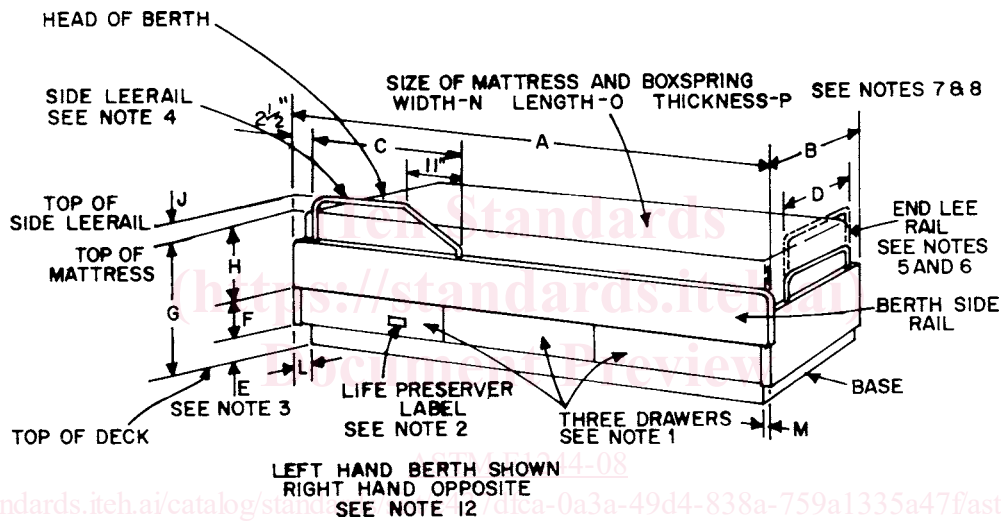

NOTE 1—For a description of the drawers, see Specification F 825. The minimum stowage capacity of each drawer shall be 1.35 ft³ (0.038 m³) (drawer pulls not shown).

NOTE 2—The location of life preserver stowage shall be indicated on the front face of one drawer. See 6.10 for description.

NOTE 3—The minimum value for Dimension “E” (toe space height) shall be 3¼ in. (83 mm).

NOTE 4—Berth Types I, II, or III, with pipe rail detail, will be supplied as shown on Fig. 1. For description of pipe rail, see 6.12.

NOTE 5—End lee rail for bottom berths that are to be installed athwartship shall be furnished extending above the mattress, to restrain occupant in heavy seas. (See 5.1.6.2.)

NOTE 6—See 6.12 for a description of the pipe lee rail.

NOTE 7—For a description of the mattress and box springs, see Specification F 1085.

NOTE 8—The mattress and box spring are ordered 1 in. (25.4 mm) smaller in width and length than the inside dimensions of the berth pan.

NOTE 9—Dimensions G, H, I, and J are shown as nominal dimensions, without tolerances. Their real value depends upon the tolerance of the thickness of the mattress and the box spring. The commercial tolerance on these thicknesses is ±½ in. (12 mm).

NOTE 10—Where ceiling heights are low, overhead clearance, Dimension I, should be equalized between upper and lower berths. Minimum clearance is 20 in. (508 mm).

NOTE 11—Fig. 1 and Fig. 2 depict the basic berth Types I, II, and III covered by these specifications. If special architectural requirements are needed to match other furniture in the same area, they shall be defined in the ordering specifications and berths will be identified as Types IA, IIA, and IIIA.

NOTE 12—For hand of berths see 3.1.6.

FIG. 1 Type I (53-in. (1345-mm) wide mattress) and Type II (38-in. (965-mm) wide mattress) Berths With Pipe, Side Lee Rail

5.1.2 *Quantity*—The quantity of right hand, left hand, or finished both sides for each type.

5.1.3 *Mattress and Box Spring*—Shall be furnished in accordance with Specification F 1085.

5.1.4 *Paint*:

5.1.4.1 *Color*—The purchaser shall pick from manufacturer’s samples or submit a sample chip of the color desired.

5.1.4.2 The manufacturer’s standard baked enamel will be furnished unless otherwise required and specified by the purchaser.

5.1.5 *Weights*—If the total weight of the berth assembly is required, it shall be requested by the purchaser.