



Standard Test Method for Burning Quality of Kerosine¹

This standard is issued under the fixed designation D 187; the number immediately following the designation indicates the year of original adoption or, in the case of revision, the year of last revision. A number in parentheses indicates the year of last reapproval. A superscript epsilon (ϵ) indicates an editorial change since the last revision or reapproval.

This standard has been approved for use by agencies of the Department of Defense.

~~^{ε1}Note—Warning notes were editorially moved into text in November 2003.~~

1. Scope*

1.1 This test method covers the qualitative determination of the burning properties of kerosine to be used for illuminating purposes. (~~Warning—~~Combustible. Vapor harmful.)

NOTE 1—The corresponding Energy Institute of Petroleum (IP) test method is IP 10 which features a quantitative evaluation of the wick-char-forming tendencies of the kerosine, whereas Test Method D 187 features a qualitative performance evaluation of the kerosine. Both test methods subject the kerosine to somewhat more severe operating conditions than would be experienced in typical designated applications.

1.2 The values stated in SI units are to be regarded as standard. No other units of measurement are included in this standard.

1.3 This standard does not purport to address all of the safety concerns, if any, associated with its use. It is the responsibility of the user of this standard to establish appropriate safety and health practices and determine the applicability of regulatory limitations prior to use. Specific warning statements appear throughout the test method.

2. Referenced Documents

2.1 ASTM Standards:²

D 91 Test Method for Precipitation Number of Lubricating Oils

D 3699 Specification for Kerosine

D 4057 Practice for Manual Sampling of Petroleum and Petroleum Products

D 4177 Practice for Automatic Sampling of Petroleum and Petroleum Products

2.2 Energy Institute Standard:³

IP 10 Determination of kerosine burning characteristics - 24 hour method

2.3 Other Document:⁴

Formulas for Denatured Alcohol and Rum; Treasury Dept., U. S. Bureau of Alcohol, Tobacco, and Firearms, Publication No. 368

3. Summary of Test Method

3.1 The kerosine sample is burned for 16 h in a specified lamp under specified conditions. The average rate of burning, the change in the shape of the flame, and the density and color of the chimney deposit are reported.

4. Significance and Use

4.1 Since the information provided by this test method is largely qualitative in nature, specific limits covering the following characteristics are required in referring to this test method in specifications for kerosine:

4.1.1 Duration of the test: 16 h is understood, if not otherwise specified;

4.1.2 Permissible change in flame shape and dimensions during the test;

¹ This test method is under the jurisdiction of ASTM Committee D02 on Petroleum Products and Lubricants and is the direct responsibility of Subcommittee D02.E0.01 on Burner, Diesel, Non-Aviation Gas Turbine, and Marine Fuel Oils—Burner Fuels.

Current edition approved Nov. Dec. 1, 2003-2008. Published November 2003-December 2008. Originally approved in 1948. Last previous edition approved in 1999-2003 as D187-94 (1999); D 187-94(2003)^{ε1}.

² For referenced ASTM standards, visit the ASTM website, www.astm.org, or contact ASTM Customer Service at service@astm.org. For Annual Book of ASTM Standards volume information, refer to the standard's Document Summary page on the ASTM website.

³ Available from U.S. Government Printing Office Superintendent of Documents, 732 N. Capitol St., NW, Mail Stop: SDE, Washington, DC 20401.

⁴ Available from Energy Institute, 61 New Cavendish St., London, W1G 7AR, U.K., <http://www.energyinst.org.uk>.

^{ε1} The sole source of supply of the apparatus known to the committee at this time is Stanhope-Seta Limited, Park Close, Englefield Green, Egham, Surrey, England TW20 0XD. If you are aware of alternative suppliers, please provide this information to ASTM International Headquarters. Your comments will receive careful consideration at a meeting of the responsible technical committee, which you may attend.

⁴ Available from U.S. Government Printing Office Superintendent of Documents, 732 N. Capitol St., NW, Mail Stop: SDE, Washington, DC 20401.

*A Summary of Changes section appears at the end of this standard.

4.1.3 Description of the acceptable appearance of the chimney deposit.

5. Apparatus

5.1 *Lamp Assembly*,⁵ conforming essentially to the shape and dimensions shown in Fig. 1. It is essential to ensure that the burner fits vertically into the oil reservoir and that the wick-guide has parallel sides and is centrally disposed in relation to the slot in the dome of the burner. Any distortion of the wick-guide or dome will hinder attainment of the prescribed flame shape and render subsequent qualitative ratings unreliable.

5.2 *Wick*,⁵ 19-mm paraffin flat, super quality, containing approximately 43 ends of three-ply yarn, woven double plain weave with stitching ends, one blue stripe on one face and one green stripe on the reverse face, woven with approximately 16 picks per 10 mm, and weighing normally 15 g/m. After weaving, the wick shall be boiled in distilled water and dried thoroughly.

⁵ Supporting data have been filed at ASTM International Headquarters and may be obtained by requesting Research Report RR: D02-1160.

⁵ The sole source of supply of the apparatus known to the committee at this time is Stanhope-Seta Limited, Park Close, Englefield Green, Egham, Surrey, England TW20 OXD. If you are aware of alternative suppliers, please provide this information to ASTM International Headquarters. Your comments will receive careful consideration at a meeting of the responsible technical committee, which you may attend.

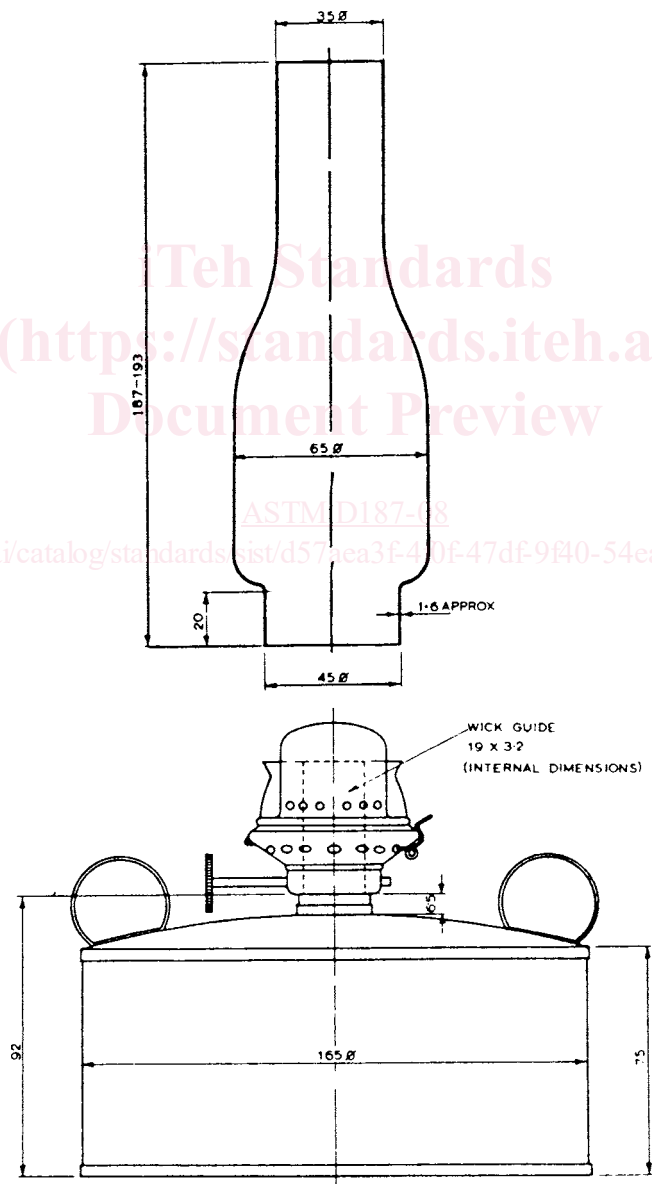

NOTE—All dimensions shown are in millimetres. Except where otherwise indicated, the tolerance for chimney dimensions is ± 1 mm.

FIG. 1 Test Lamp

5.2.1 The wick shall then be made into rolls and left for seven days before it is cut into 200-mm lengths. The lengths shall then be packed into suitable containers. The ash of the wick shall not exceed 0.4 weight %.

5.3 *Sight Gage*⁵—A suitable flame-size measuring device, accurate to 1 mm. The sight gage shown in Fig. 2 is satisfactory.

6. Reagents and Materials

6.1 *Formula 3A Denatured Ethanol* —See Formulas for Denatured Alcohol and Rum.

6.2 *Hydrochloric Acid, Dilute* (approximately 6 N).

6.3 *Kerosine*—See Specification D 3699.

6.4 *Precipitation Naphtha*—See Reagent section in Test Method D 91.

7. Hazards

7.1 *Specific Safety Hazards:*

7.1.1 *Formula 3A Denatured Ethanol* —(**Warning**—Flammable. Denatured—cannot be made nontoxic.)

7.1.2 *Hydrochloric Acid*—Dilute 6 N. (**Warning**— Causes burns. Vapor harmful.)

7.1.3 *Kerosine*—(**Warning**—Combustible. Vapor harmful.)

7.1.4 *Precipitation Naphtha*—(**Warning**—Extremely flammable. Harmful if inhaled. Vapors may cause flash fire.)

7.2 *Technical Precautions:*

7.2.1 *Test Room*—It is desirable to dedicate a suitable room for the exclusive conduct of kerosine burning tests. However, kerosine burning tests can be conducted in any part of a room that is adequately ventilated and reasonably free of drafts. When necessary, the test lamp should be surrounded with a suitable circular shield to protect from drafts. The circular shield is to be constructed of draft-proof material of about 600 mm diameter and height.

7.2.2 *Lamp Location*— Place the test lamps at least 300 mm apart and 300 mm from any wall or other obstruction.

7.2.3 *Test Temperature*— Maintain test room temperature above 15°C and allow the temperature of the kerosine to approach equilibrium room temperature within at least 5°C.

8. Sampling

8.1 The fundamental objective of sampling is to obtain a sample for testing purposes that is truly representative of the entire quantity of a given bulk product tank, batch, shipment, and so forth, at the time and place of sampling.

8.2 Thus, the sampling procedures employed are to ensure initial procurement of a representative sample and also preclude subsequent contamination or deterioration of the sample during handling prior to testing. To this end, kerosine samples for burning quality testing are to be obtained and handled in strict accordance with Practices D 4057 and D 4177. Rigorous compliance with stipulated provisions for precautions, care, and cleanliness during sample handling is an essential requirement.

9. Preparation of Apparatus

9.1 Drain the lamp reservoir completely of any previous kerosine sample (**Warning**—Combustible. Vapor harmful), and rinse successively several times with a small portion of the kerosine sample to be tested.

9.2 Clean the lamp burner thoroughly with ASTM precipitation naphtha solvent (**Warning**—Extremely flammable. Harmful if inhaled: vapors may cause flash fire), removing completely any deposits from the wick-guide, air holes, and ducts.

9.3 Soak the new chimneys for 24 h in dilute HCl (**Warning**—Causes burns. Vapor harmful) (approximately 6 N), clean with a test tube brush, rinse thoroughly with distilled water, and dry completely. Then subject the prepared new chimneys to at least

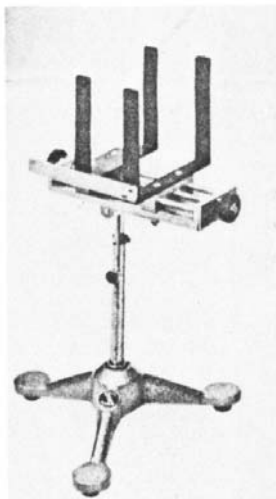

FIG. 2 Sight Gage