



Designation: ~~D5287-97~~ (Reapproved 2002) Designation: D 5287 - 08

Standard Practice for Automatic Sampling of Gaseous Fuels¹

This standard is issued under the fixed designation D 5287; the number immediately following the designation indicates the year of original adoption or, in the case of revision, the year of last revision. A number in parentheses indicates the year of last reapproval. A superscript epsilon (ϵ) indicates an editorial change since the last revision or reapproval.

1. Scope

~~1.1 This practice covers the collection of natural gases and their synthetic equivalents using an automatic sampler.~~
~~1.2 This practice applies only to single-phase gas mixtures that vary in composition. A representative sample cannot be obtained from a two-phase stream.~~

1.1 This practice covers the collection of gaseous fuels and their synthetic equivalents using an automatic sampler.

1.2 This practice applies only to single-phase gas mixtures. This practice does not address a two-phase stream.

1.3 This practice includes the selection, installation, and maintenance of automatic sampling systems.

1.4 This practice does not include the actual analysis of the acquired sample. Other applicable ASTM standards, such as Test Method D 1945, should be ~~referenced~~ used to acquire that information.

1.5 The selection of the sampling system is dependent on several interrelated factors. These factors include source dynamics, operating conditions, cleanliness of the source gases, potential presence of moisture and hydrocarbon liquids, and trace hazardous components. For clean, dry gas sources, steady source dynamics, and normal operating conditions, the system can be very simple. As the source dynamics become more complex and the potential for liquids increases, or trace hazardous components become present, the complexity of the system selected and its controlling logic must be increased. Similarly, installation, operation, and maintenance procedures must take these dynamics into account.

~~1.6 The values stated in inch-pound units are to be regarded as the standard. The values given in parentheses are for information only.~~

1.6 The values stated in inch-pound units are to be regarded as standard. The values given in parentheses are mathematical conversions to SI units that are provided for information only and are not considered standard.

1.7 *This standard does not purport to address all of the safety concerns, if any, associated with its use. It is the responsibility of the user of this standard to establish appropriate safety and health practices and determine the applicability of regulatory limitations prior to use.*

2. Referenced Documents

2.1 ASTM Standards:²

D 1945 Test Method for Analysis of Natural Gas by Gas Chromatography

2.2 Other Standards:

AGA Report Number 7 Measurement of Gas by Turbine Meters³

API 14.1 Collecting and Handling of Natural Gas Samples for Custody Transfer⁴

API 14.3 Part 2 (AGA Report Number 3)⁴

GPA Standard 2166 Methods of Obtaining Natural Gas Samples for Analysis by Gas Chromatography⁵

ISO-10715 Natural Gas—Sampling Guidelines⁶

NACE Standard MR-01-75 Standard Material Requirements. Sulfide Stress Cracking Resistant-Metallic Materials for Oilfield Equipment⁷

¹ This practice is under the jurisdiction of ASTM Committee D03 on Gaseous Fuels and is the direct responsibility of Subcommittee D03.01 on Collection and Measurement of Gaseous Samples.

Current edition approved Nov. 10, 2002; Dec. 1, 2008. Published May 2003; December 2008. Originally approved in 1992. Last previous edition approved in 2002 as D 5287 - 97 (2002).

² For referenced ASTM standards, visit the ASTM website, www.astm.org, or contact ASTM Customer Service at service@astm.org. For *Annual Book of ASTM Standards*, Vol. 05.06, volume information, refer to the standard's Document Summary page on the ASTM website.

³ Available from American Gas Association, 400 N. Capitol St. N.W., Washington, DC 20001, <http://www.aga.org/>.

⁴ Available from the American National Standards Institute (ANSI), 25 W. 43rd St., 4th Floor, New York, NY 10036, <http://www.ansi.org>.

⁵ Available from Gas Processors Association (GPA), 6526 E. 60th St., Tulsa, OK 74145, <http://www.gasprocessors.com>.

⁶ Available from National Association of Corrosion Engineers, 1440 South Creek Dr., Houston, TX 77084.

⁷ Available from International Organization for Standardization (ISO), 1, ch. de la Voie-Creuse, Case postale 56, CH-1211, Geneva 20, Switzerland, <http://www.iso.ch>.

⁸ Available from Superintendent of Documents, Government Printing Office, Washington, DC 20402.

2.3 Federal Documents:

Code of Federal Regulations, Title 49,173, 34(e), p. 389 CFR 49 Code of Federal Regulations, Title 49,173, 34(e), p. 389⁸

3. Terminology

3.1 Definitions of Terms Specific to This Standard:

3.1.1 *automatic sampler*—(see Fig. 1(a) and (b)) a mechanical system, composed of a sample probe, sample loop, sample extractor, sample vessel, and the necessary logic circuits to control the system throughout a period of time, the purpose of which is to compile representative samples in such a way that the final collection is representative of the total composition of the gas stream for that period of time.

3.1.2 *representative sample*—a volume of gas that has been obtained in such a way that the composition of this volume is the same as the total composition of the gas stream from which it was taken.

3.1.3 *retrograde condensation*—the formation of liquid phase by pressure drop at constant temperature on a dew-point gas stream.—the formation of liquid phase by pressure drop or temperature increase on a gas stream at or below hydrocarbon dew point.⁹

3.1.4 *sample extractor*—a device to remove the sample from the flowing stream or sample loop and put it into the sample vessel.

3.1.5 *sample loop*—the valve, tubing, or manifold(s), or combination thereof, used for conducting the gas stream from the probe to the sampling device and back to the source pipe (or atmosphere).

3.1.6 *sample probe*—that portion of the sample loop attached to and extending into the pipe containing the gas to be sampled.

3.1.7 *sample vessel*—the container in which the sample is collected, stored, and transported to the analytical equipment.—the container in which the sample is collected, stored, and transported to the analytical equipment. This is also referred to as a sample cylinder.

⁷ Available from NACE International (NACE), 1440 South Creek Dr., Houston, TX 77084-4906, <http://www.nace.org>.

⁸ Bergman, D. F., Tek, M. R., and Katz, D. L., *Retrograde Condensation in Natural Gas Pipelines*, American Gas Association, Arlington, VA, 1975.

⁸ Available from Superintendent of Documents, Government Printing Office, Washington, DC 20402.

⁹ The sole source of supply of Krytox AC and AD known to the committee at this time is DuPont Co., Chemicals & Pigments Dept., 1007 Market St., Wilmington, DE 19898. If you are aware of alternative suppliers, please provide this information to ASTM International Headquarters. Your comments will receive careful consideration at a meeting of the responsible technical committee, which you may attend.

⁹ Bergman, D. F., Tek, M. R., and Katz, D. L., *Retrograde Condensation in Natural Gas Pipelines*, American Gas Association, Arlington, VA, 1975.

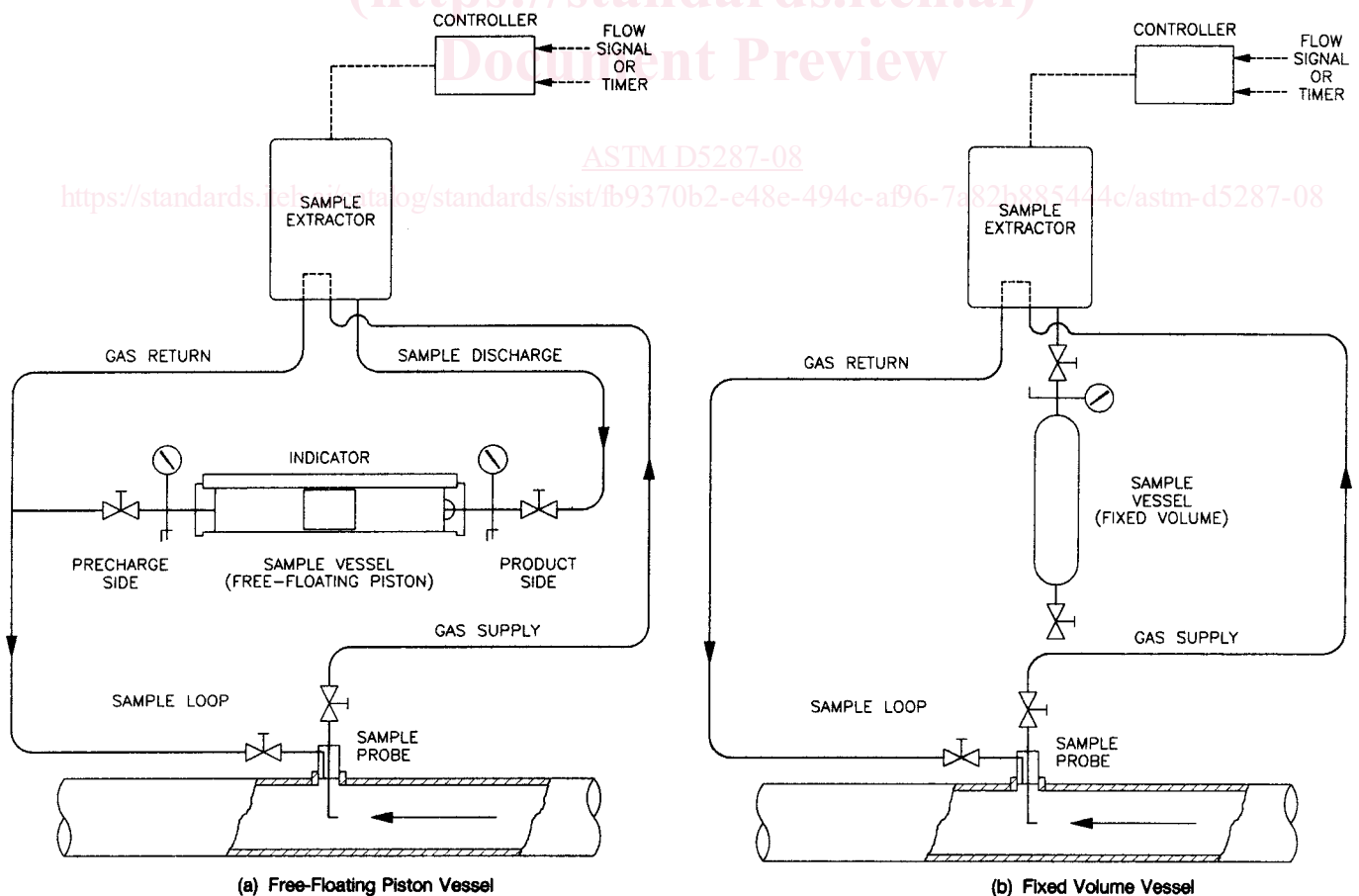

FIG. 1 Continuous Composite Samplers

3.1.8 *source dynamics*—changes in gas supplies, operating pressures, temperatures, flow rate, hydrocarbon dew point, and other factors that may affect composition or state, or both.

4. Significance and Use

4.1 ~~This practice should be used when and where a representative sample is required. A representative sample is necessary for accurate billing in custody transfer transactions.~~

4.2 ~~This practice is not intended to preempt existing contract agreements.~~

4.1 This practice should be used when and where a representative sample is required. A representative sample is necessary for accurate billing in custody transfer transactions, accurate compositional analysis of the flowing stream, gravity determination for flow calculations and other desired information concerning the properties of the stream contents.

4.2 This practice is not intended to preempt existing contract agreements or regulatory requirements.

4.3 Principles pertinent to this practice may be applied in most contractual agreements.

4.4 **Warning**—Many gages are extremely flammable and can contain toxic substances. Caution should be taken in all aspects of sample collection and handling. Sample vessels should only be handled in well ventilated locations away from sparks and flames. Improper handling can result in an explosion or injury, or both.

5. Material Selection

5.1 ~~The sampling system should be constructed of materials that will not corrode as a result of ambient conditions.~~

5.2 ~~The selected material should be inert to all expected components of the gas stream.~~

5.3 ~~If sour gas (gas that contains hydrogen sulfide and carbon dioxide) is suspected, NACE standard MR-01-75 should be adhered to:~~

5.1 The sampling system (including probes, tubing, valving and other components) should be constructed of suitable inert, or passivated, materials that are compatible with all aspects of the product and the sampling practice, both internal and external conditions to ensure that constituents in the fuel stream do not degrade these components or alter the composition of the sampled gas.

5.2 The selected material should be inert to and not absorptive of all expected components in the gas stream.

5.3 When sour gas (gases that contain hydrogen sulfide or carbon dioxide, or both) are present or suspected, consult the recommendations in NACE Standard MR-01-75.

5.4 Contaminates, other than those listed above, should be identified and addressed by the appropriate industry recommendations, guidelines and standards.

6. Sample Probe (see Fig. 2 and Fig. 3)

6.1 The sample probe should be mounted vertically in a horizontal run.

6.2 The sample probe should penetrate into the center one third of the pipeline.

6.3 ~~The sample probe should not be located within the defined meter-tube measurement region. (See (For example see API 14.3, Part 2, Paragraph 2.5.1).~~

6.4 ~~The sample probe should be constructed of stainless steel.~~

6.5 ~~The sample probe should be a minimum of five pipe diameters from any device that could cause aerosols or significant pressure drop.~~

6.4 The sample probe should be constructed of stainless steel. (See also, 5.2.)

6.5 The sample probe should be a minimum of five pipe diameters downstream from any device that could cause aerosols or significant pressure drop such as orifice plates, thermowelds, elbows and the like.

6.6 The probe should be designed using probe calculations with regard to wake frequency and resonant vibration impact. (See API 14.1, paragraph 7.4.1)

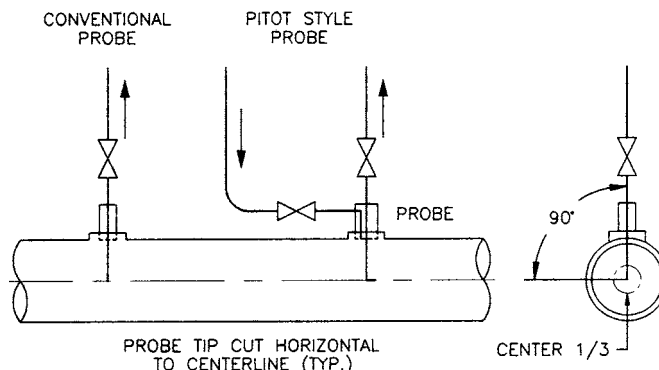

FIG. 2 Acceptable Probe Types and Installations

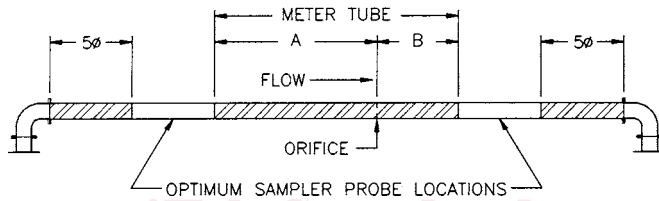
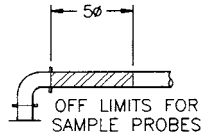
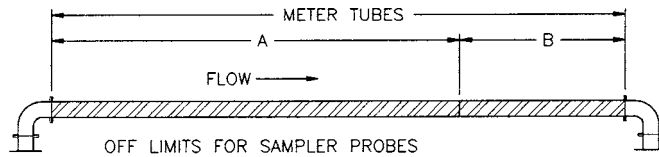

FIG. 3 Probe Locations

7. Sample Loop (see Fig. 4)

- 7.1 All valves should be straight bore, full opening, stainless steel valves.
- 7.1 All valves should be straight bore, full opening, stainless steel ball valves or full ported valves. In some applications, specially coated or passivated materials may be required.
- 7.2 The sample loop should be 1/4-in. (6.25-mm) or less outside diameter stainless steel tubing.
- 7.3 The supply line shall slope from the probe up to the sampler. All traps caused by low points shall be avoided.
- 7.4 The return line should slope down from the sampler to a connection of lower pressure on the pipeline. 1/4-in. (6.25-mm) or less outside diameter stainless steel tubing. In some applications, specially coated or passivated materials may be required.
- 7.3 The supply line shall slope from the probe up to the sampler and not possess regions or traps where condensate or fluid can collect.

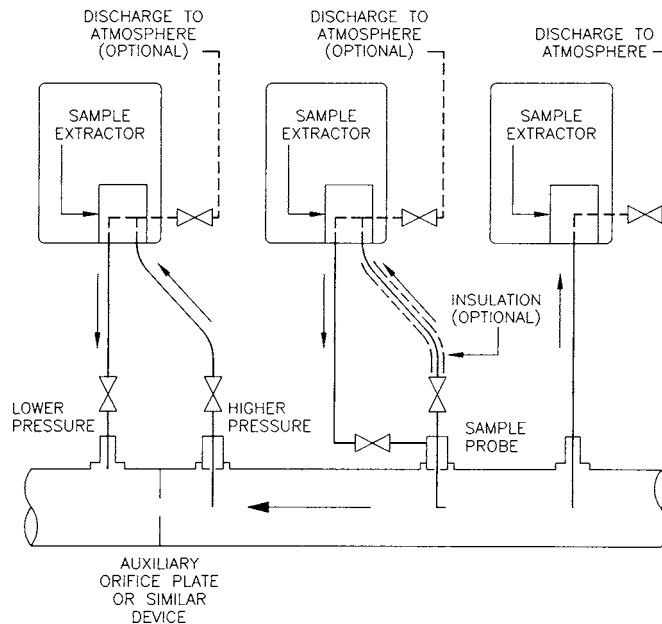

FIG. 4 Schematics of Acceptable Sample Loops