



Designation: E238 – 84 (Reapproved 2008)

Standard Test Method for Pin-Type Bearing Test of Metallic Materials¹

This standard is issued under the fixed designation E238; the number immediately following the designation indicates the year of original adoption or, in the case of revision, the year of last revision. A number in parentheses indicates the year of last reapproval. A superscript epsilon (ϵ) indicates an editorial change since the last revision or reapproval.

1. Scope

1.1 This test method covers a pin-type bearing test of metallic materials to determine bearing yield strength and bearing strength.

NOTE 1—The presence of incidental lubricants on the bearing surfaces may significantly lower the value of bearing yield strength obtained by this method.

1.2 *Units*—The values stated in inch-pound units are to be regarded as standard. The values given in parentheses are mathematical conversions to SI units that are provided for information only and are not considered standard.

1.3 *This standard does not purport to address all of the safety concerns, if any, associated with its use. It is the responsibility of the user of this standard to establish appropriate safety and health practices and determine the applicability of regulatory limitations prior to use.*

2. Referenced Documents

2.1 *ASTM Standards*:²

E4 Practices for Force Verification of Testing Machines

E6 Terminology Relating to Methods of Mechanical Testing

E83 Practice for Verification and Classification of Extensometer Systems

3. Terminology

3.1 *Definitions*:

3.1.1 *bearing area*—the product of the pin diameter and specimen thickness.

3.1.2 *bearing stress*—the force per unit of bearing area.

3.1.3 *bearing strain*—the ratio of the bearing deformation of the bearing hole, in the direction of the applied force, to the pin diameter.

¹ This test method is under the jurisdiction of ASTM Committee E28 on Mechanical Testing and is the direct responsibility of Subcommittee E28.04 on Uniaxial Testing.

Current edition approved May 1, 2008. Published December 2008. Originally approved in 1964. Last previous edition approved in 2002 as E238 – 84 (2002). DOI: 10.1520/E0238-84R08.

² For referenced ASTM standards, visit the ASTM website, www.astm.org, or contact ASTM Customer Service at service@astm.org. For *Annual Book of ASTM Standards* volume information, refer to the standard's Document Summary page on the ASTM website.

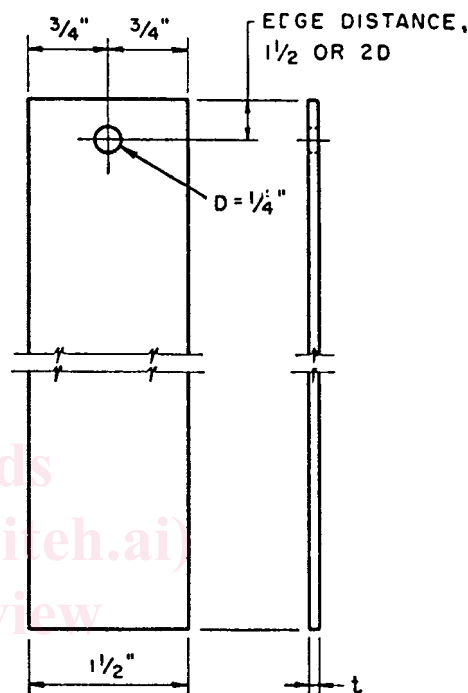

FIG. 1 Bearing Test Specimen

3.1.4 *bearing yield strength*—the bearing stress at which a material exhibits a specified limiting deviation from the proportionality of bearing stress to bearing strain.

3.1.5 *bearing strength*—the maximum bearing stress which a material is capable of sustaining.

3.1.6 *edge distance*—the distance from the edge of a bearing specimen to the center of the hole in the direction of applied force (Fig. 1).

3.1.7 *edge distance ratio*—the ratio of the edge distance to the pin diameter.

3.1.8 For definitions of other terms see Terminology E6.

4. Significance and Use

4.1 The data obtained from the bearing test are the bearing ultimate and yield strength. The data provide a measure of the load-carrying capacity of a material edge loaded with a close-fitting cylindrical pin through a hole located a specific distance from the specimen edge.

TABLE 1 Characteristics of Pin for Various Materials Tested

Material Tested	Material	Rockwell Hardness	Surface Roughness, μ in. (μ m) (avg)
Aluminum alloys	hardened steel	C60 to 64	4 to 8 (0.1 to 0.2 μ m)
Beryllium alloys	hardened steel	C60 to 64	4 to 8 (0.1 to 0.2 μ m)
Copper alloys	hardened steel	C60 to 64	4 to 8 (0.1 to 0.2 μ m)
Magnesium alloys	hardened steel	C60 to 64	4 to 8 (0.1 to 0.2 μ m)
Zinc alloys	hardened steel	C60 to 64	4 to 8 (0.1 to 0.2 μ m)

4.2 Bearing properties are useful in the comparison of materials and design of structures under conditions where the pin is not restricted.

5. Apparatus

5.1 *Testing Machines*—Machines used for bearing testing shall conform to the requirements of Practices E4.

5.2 *Gripping Devices*—Various types of gripping devices may be used to transmit the measured load applied by the testing machine to the test specimens. Any grips considered to apply the load axially for tension testing, such as pin connections or wedge grips, are satisfactory for use in bearing testing.

5.3 *Pin*—The bearing load is generally applied to the specimen through a close-fitting cylindrical pin. The pin shall be harder and stronger than the material being tested. Restraint of movement of the specimen where it is in contact with the pin has a considerable effect upon the hole deformation obtained as a function of the load applied. Close control of surface conditions on both the specimen and pin is needed to assure reproducible results. The pins used should be uniform in diameter, hardness, and surface roughness. Pin materials, hardness, and surface roughness as shown in Table 1 are recommended for testing the materials listed. The pin should be checked carefully after each test to ensure that no metallic residue adheres to it and that it is both straight and undeformed. If there is any question regarding its quality it should be replaced.

5.4 *Pin Support*—The jig supporting the pin should position the pin concentric with the hole in the specimen. It should not restrain the thickening of the specimen as the load from the pin deforms the hole. Bending of the pin should be kept to a minimum by having the jig support the pin close to the specimen. Fig. 2 and Fig. 3 show examples of the types of jig that have been used and are considered satisfactory.

5.5 *Extensometers*—Extensometers used for measuring the bearing deformation shall comply with the requirements for Class B-2 or better as described in Practice E83. The bearing deformation measurement shall be made in a manner to obtain the axial bearing deformation with a minimum of other deformations being included such as the bending of the pin and tensile strain in the specimen. Fig. 2 shows an adaptation of a Templin extensometer system to record bearing deformation. Fig. 3 illustrates a mechanism that can be used to transfer the bearing deformation so it can be measured with the same extensometers used for tension testing. A method of measuring bearing deformation featuring two linear differential transformers is shown in Fig. 4.

6. Test Specimens

6.1 *Specimen Dimensions*—The specimen shall be a flat sheet type, with the full thickness of the product being used if

possible. If the specimen is too thick in relation to the pin diameter, the pin is liable to bend considerably or break before the bearing strength is obtained. If a specimen is too thin, buckling may occur. A ratio of pin diameter to specimen thickness of from 2 to 4 has been used to avoid both conditions. The hole should have approximately the same diameter as for the intended use. For example, if the bearing test results are being used to obtain data for a riveted part, a hole $\frac{3}{16}$ in. or $\frac{1}{4}$ in. (5 or 6 mm) in diameter would be suitable, while for a bolted assembly, a larger hole might be desirable. A difference in test results may be obtained with holes of different diameters. The width of the specimen should be about 4 to 8 times the hole diameter. The edge distance ratio shall be specified and the edge distance held within a tolerance of $\pm 2\%$. Edge distance ratios of $1\frac{1}{2}$ and 2 are commonly used (see Fig. 1). A close fit between the specimen and pin is required since a loose fit will tend to give lower results. The diameter of the hole should not exceed the pin diameter by more than 0.001 in. (0.02 mm). The total length of the test specimen is not critical and may depend on the method used to grip the specimen. Fig. 1 shows a bearing test specimen commonly used.

6.2 *Specimen Preparation*—A flat specimen with a hole normal to the face shall be used. A smooth, round hole with a minimum of cold work on the surface must be obtained. The finished hole is generally bored, reamed, or ground as a final operation to obtain the desired degree of roundness. Any burr on the periphery of the hole is indicative of a cold-worked surface on the hole and should be avoided. Removal of the burr will not eliminate the cold work.

7. Procedure

7.1 *Measurement of Specimens*—Measure the actual thickness of the specimen and the pin diameter, preferably reading to at least the nearest 0.5 % of the dimension measured, and in any case to at least the nearest 0.001 in. (0.02 mm). Calculate the stress on the basis of the measured dimensions. Measure the edge distance to the nearest 0.01 in. (0.2 mm).

7.2 *Cleaning*—Clean the specimen, pin, and adjacent areas of the jig of all foreign matter and contamination, especially lubricants, prior to assembly. Keep in that condition until the test is completed. It has been found that oil from human fingers touching the pin significantly lowers the results of the test. A handle on the pin has been found to help in keeping fingers from touching the test area of the pin. Recommended methods of cleaning are given in the Appendix X1.³ The cleaners recommended for the materials given in the Appendix X1 are generally satisfactory for cleaning the pin and fixtures, too.

7.3 *Testing*—Load the specimen and obtain simultaneous readings of the load and bearing deformation. Any convenient method of load application and system of strain recording may be used. Autographic strain recording equipment can be readily adapted to measure bearing deformation (see Figs. 1-5).

³ Stickley, G. W., and Moore, A. A., "Effects of Lubrication and Pin Surface on Bearing Strengths of Aluminum and Magnesium Alloys," MTRSA, *Materials Research & Standards* Vol 2, No. 9 pp. 747 September 1962