



Designation: ~~E328–86 (Reapproved 1996)~~<sup>ε1</sup> Designation: E 328 – 02 (Reapproved 2008)

## Standard Test Methods for Stress Relaxation for Materials and Structures<sup>1</sup>

This standard is issued under the fixed designation E 328; the number immediately following the designation indicates the year of original adoption or, in the case of revision, the year of last revision. A number in parentheses indicates the year of last reapproval. A superscript epsilon ( $\epsilon$ ) indicates an editorial change since the last revision or reapproval.

~~<sup>ε1</sup>Note—The title was changed editorially in January 1996.~~

### INTRODUCTION

These test methods cover a broad range of testing activities. To aid in locating the subject matter pertinent to a particular test, the standard is divided into a general section, which applies to all stress relaxation tests for materials and structures. This general section is followed by letter-designated parts that apply to tests for material characteristics when subjected to specific, simple stresses, such as uniform tension, uniform compression, bending or torsion. To choose from among these types of ~~loading, stress,~~ the following factors should be considered:

(1) When the material data are to be applied to the design of a particular class of component, the stress during the relaxation test should be similar to that imposed on the component. For example, tension tests are suitable for bolting applications and bending tests for leaf springs.

(2) Tension and compression relaxation tests have the advantage that the stress can be reported simply and unequivocally. During bending relaxation tests, the state of stress is complex, but can be accurately determined when the initial strains are elastic. If plastic strains occur on ~~loading, application of force,~~ stresses can usually be determined within a bounded range only. Tension relaxation tests, when compared to compression tests, have the advantage that it is unnecessary to guard against buckling. Therefore, when the test method is not restricted by the type of stress in the component, tension testing is recommended.

(3) Bending tests for relaxation, when compared to tension and compression tests, have the advantage of using lighter and simpler apparatus for specimens of the same cross-sectional area. Strains are usually calculated from deflection or curvature measurements. Since the specimens can usually be designed so that these quantities are much greater than the axial deformation in a direct stress test, strain is more easily measured and more readily used for machine control in the bending tests. Due to the small forces normally required and the simplicity of the apparatus when static fixtures are sufficient, many specimens can be placed in a single oven or furnace when tests are made at elevated temperatures.

### 1. Scope

NOTE 1—The method of testing for the stress relaxation of plastics has been withdrawn from this standard, and the responsibility has been transferred to Practice D 2991.

1.1 These test methods cover the determination of the time dependence of stress (stress relaxation) in materials and structures under conditions of approximately constant constraint, constant environment, and negligible vibration. In the procedures recommended, the material or structure is initially constrained by externally applied forces, and the change in the external force necessary to maintain this constraint is determined as a function of time.

1.2 Specific methods for conducting stress relaxation tests on materials subjected to tension, compression, bending and torsion ~~loads~~ stresses are described in Parts A, B, C, and D, respectively. These test methods also include recommendations for the necessary testing equipment and for the analysis of the test data.

1.3 It is recognized that the long time periods required for these types of tests are often unsuited for routine testing or for

<sup>ε</sup>These test methods are under the jurisdiction of ASTM Committee E28 on Mechanical Testing and is the direct responsibility of Subcommittee E28.10 on Effect of Elevated Temperature on Properties.

Current edition approved Feb. 28, 1986. Published May 1986. Originally published as E328–67T. Last previous edition E328–78.

<sup>1</sup> These test methods are under the jurisdiction of ASTM Committee E28 on Mechanical Testing and is the direct responsibility of Subcommittee E28.04 on Uniaxial Testing.

Current edition approved May 1, 2008. Published December 2008. Originally approved in 1967. Last previous approved in 2002 as E 328–02.

specification in the purchase of material. However, these tests are valuable tools in obtaining practical design information on the stress relaxation of materials subjected to the conditions enumerated, and in investigations of the fundamental behavior of materials.

1.4 *Units*—The values stated in inch-pound units are to be regarded as standard. The values given in parentheses are mathematical conversions to SI units that are provided for information only and are not considered standard.

1.5 *This standard does not purport to address all of the safety concerns, if any, associated with its use. It is the responsibility of the user of this standard to establish appropriate safety and health practices and determine the applicability of regulatory limitations prior to use.*

## 2. Referenced Documents

### 2.1 ASTM Standards:<sup>2</sup>

D 2991 [Recommended Practice for Testing Stress-Relaxation of Plastics](#)<sup>3</sup>

E 4 [Practices for Force Verification of Testing Machines](#)

E 8/E 8M [Test Methods for Tension Testing of Metallic Materials](#)

E 9 [Test Methods of Compression Testing of Metallic Materials at Room Temperature](#)

E 83 [Practice for Verification and Classification of Extensometer Systems](#)

E 139 ~~[Practice for Conducting Creep, Creep-Rupture, and Stress-Rupture Tests of Metallic Materials](#)~~<sup>3</sup> [Test Methods for Conducting Creep, Creep-Rupture, and Stress-Rupture Tests of Metallic Materials](#)

E 1012 [Practice for Verification of Test Frame and Specimen Alignment Under Tensile and Compressive Axial Force Application](#)

## 3. Terminology

### 3.1 Definitions:

3.1.1 *stress relaxation*—the time-dependent decrease in stress in a solid under given constraint conditions.

3.1.1.1 *Discussion*—The general stress relaxation test is performed by isothermally loading applying a specimen force to a specimen with fixed value of constraint. The constraint is maintained constant and the constraining force is determined as a function of time. The major problem in the stress relaxation test is that constant constraint is ~~virtually impossible~~ can be very difficult to maintain. The effects on test results are very significant and considerable attention must be given to minimize the constraint variation. Also, experimenters should determine and report the extent of variation in each stress relaxation test so that this factor can be taken into consideration.

3.1.2 *initial stress* [FL<sup>-2</sup> ]—the stress introduced into a specimen by imposing the given constraint conditions before stress relaxation begins.

3.1.2.1 *Discussion*—There are many methods of performing the stress relaxation test, each with a different starting procedure. However, the constraint is usually obtained initially by the application of the an external load force at either a specific load force application rate or a specific strain rate. The two methods will produce the characteristic behavior shown in Fig. 1 when the initial stress,  $\sigma_0$ , exceeds the proportional limit. ~~Most~~ Some testing machines, while reaching the constraint value, do not produce either a constant load force application rate or constant strain rate, but something in between. However, the general characteristics of the data will be similar to those indicated. The rate of loading stress application rate in either case should be reasonably rapid, but without impact or vibration, so that any relaxation during the loading stress application period will be small.

3.1.3 *zero time,  $t_0$* —the time when the given loading stress or constraint conditions are initially obtained in a stress relaxation test.

3.1.3.1 *Discussion*—The stress relaxation test is considered to have started at zero time,  $t_0$  in Fig. 1. ~~This is the reference time from which the observed reduction in load to maintain constant constraint is based.~~ Selection of this time does not imply that the loading procedure or period, or both, are not significant test parameters. These must always be considered in the application of the data:

3.1.4 *remaining stress* [FL<sup>-2</sup> ]—the stress remaining at a given time during a stress relaxation test.

3.1.5 *relaxed stress*—the initial stress minus the remaining stress at a given time during a stress relaxation test.

3.1.6 *stress relaxation curve*—a plot of the remaining or relaxed stress as a function of time.

3.1.6.1 *Discussion*—A curve to demonstrate that the stress relaxation behavior can be obtained by plotting either the remaining stress or the relaxed stress as a function of time (see Fig. 2). The remaining stress will, of course, decrease with time, and the relaxed stress will start at zero and increase with time as seen in Fig. 2(b):

3.1.7. *This is the reference time from which the observed reduction in force to maintain constant constraint is based. Selection of this time does not imply that the force application procedure or period, or both, are not significant test parameters. These must always be considered in the application of the data.*

<sup>2</sup> For referenced ASTM standards, visit the ASTM website, [www.astm.org](http://www.astm.org), or contact ASTM Customer Service at [service@astm.org](mailto:service@astm.org). For *Annual Book of ASTM Standards*, Vol 08.02-volume information, refer to the standard's Document Summary page on the ASTM website.

<sup>3</sup> Annual Book of ASTM Standards, Vol 03.01.

<sup>3</sup> Withdrawn. The last approved version of this historical standard is referenced on [www.astm.org](http://www.astm.org).

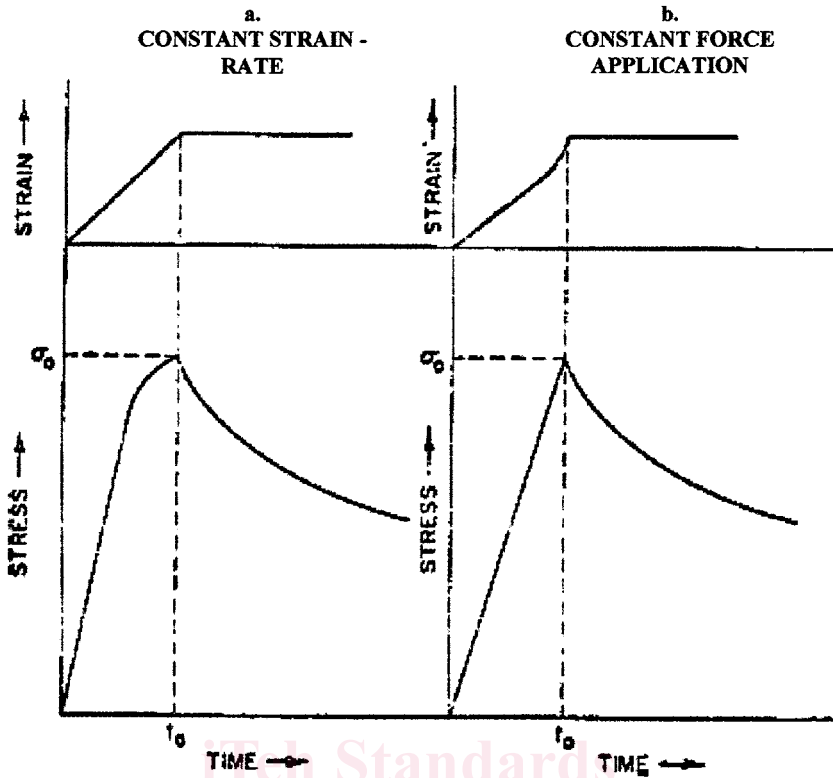

FIG. 1 Characteristic Behavior During Force Application Period in a Relaxation Test

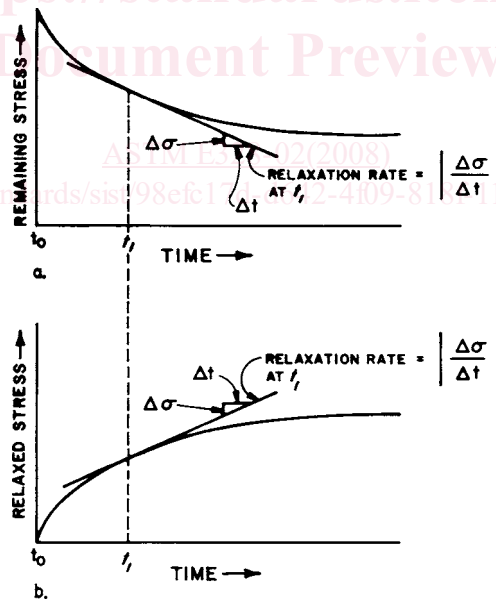

FIG. 2 Typical Relaxation Curves

3.1.4 *relaxation rate*—the absolute value of the slope of the relaxation curve at a given time.

3.1.8

3.1.5 *spherometer*—an instrument used to measure circular or spherical curvature.

3.1.9

3.1.6 *indicated nominal temperature or indicated temperature*—the temperature that is indicated by the temperature-measuring device.

#### 4. Summary of Test Methods

4.1 In each of the various methods of loading—stress application described in the applicable specific sections, the specimen is

subjected to an increasing load force until the specified initial strain is attained (see *zero time* in 3.1.3 and in Fig. 1). For the duration of the test, the specimen constraint is maintained constant. The initial stress is calculated from the initial load force (moment, torque) as measured at zero time, the specimen geometry, and the appropriate elastic constants, often using simple elastic theory. The remaining stress may be calculated from the load force (moment or torque) determined under constraint conditions either continuously (4.1.1), periodically (4.1.2), or by elastic springback at the end of the test period [4.1.3 (see Fig. 3)].

4.1.1 Readings are taken continuously from a force indicator while the apparatus adjusts the force to maintain constraint within specified bounds.

NOTE 2—Most load force, moment, or torque measuring devices depend on the devices' elasticity to measure the quantities involved. Therefore, it is necessary that when using such devices, to maintain the total strain constant within an upper and lower bound as shown in Fig. 4(a).

4.1.2 The force required to lift the specimen just free of one or more constraints during the test period is measured.

4.1.3 The elastic springback is measured after unloading removing the test stress at the end of the test period.

4.2 With 4.1.1 and 4.1.2, a single specimen can be used to obtain data for a curve of stress versus time. With 4.1.3, the same specimens may be used to determine the remaining or relaxed stress after various time intervals, if it can be demonstrated for a given material that identical results are obtained in either using virgin or reloaded specimens. Otherwise, individual specimens must be used for each point on the curve.

### 5. Significance and Use

5.1 Relaxation test data are necessary when designing most mechanically fastened joints to assure the permanent tightness of bolted or riveted assemblies, press or shrink-fit components, rolled-in tubes, etc. Other applications include predicting the decrease in the tightness of gaskets, in the hoop stress of solderless wrapped connections, in the constraining force of springs, and the stability of wire tendons in prestressed concrete.

5.2 The ability of a material to relax at high-stress concentrations such as are present at notches, inclusions, cracks, holes, fillets, etc., may be predicted from stress relaxation data. Such test data are also useful to judge the heat-treatment condition necessary for the thermal relief of residual internal stresses in forgings, castings, weldments, machined or cold-worked surfaces, etc. The tests outlined in these methods are limited to conditions of approximately constant constraint and environment.

5.3 The test results are highly sensitive to small changes in environmental conditions and thus require precise control of test conditions and methods.

5.4 The reproducibility of data will depend on the manner with which all test conditions are controlled. The effects of aging or residual stress may significantly affect results, as may variations in material composition.

### 6. Apparatus

6.1 See the appropriate paragraph under each section.

6.2 It is recommended that the equipment be located in a draft-free, constant-temperature environment,  $\pm 5^\circ\text{F}$  ( $\pm 3^\circ\text{C}$ ).

### 7. Temperature Control and Measurement

7.1 The test space (controlled temperature room, furnace, or cold box) should be capable of being maintained at a constant temperature by a suitable automatic device. This is the most important single factor in a stress relaxation test since the stress relaxation rate, dimensions, and constraint conditions of the specimen are dependent upon the test temperature. Any type of heating or cooling which permits close temperature control of the test space environment is satisfactory.

7.2 The temperature should be recorded, preferably continuously or at least periodically. Temperature variations of the specimens from the indicated nominal test temperature due to all causes, including cycling of the controller or position along the specimen gage length, should not exceed  $\pm 5^\circ\text{F}$  ( $3^\circ\text{C}$ ) or  $\pm 1/2\%$ , whichever is greater. These limits should apply initially and for the duration of the test.

7.3 The combined strain resulting from differential thermal expansion (associated with normal temperature variation of the environment) between the test specimen and the constraint and other variations in the constraint (such as elastic follow up) should not exceed  $\pm 0.000025$  in./in. (mm/mm).

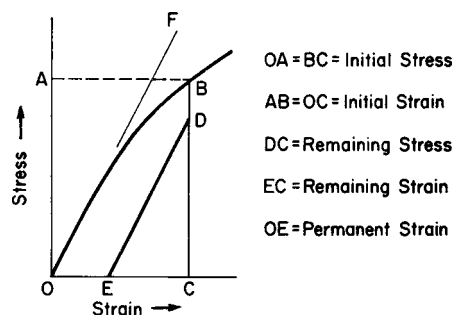
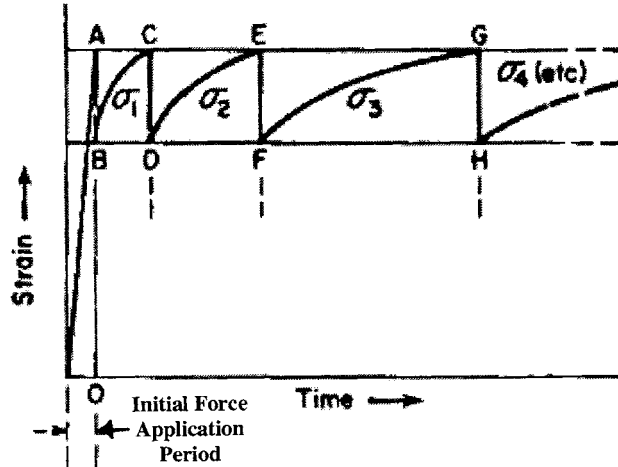

FIG. 3 Stress-Strain Diagram for Determining Relaxation in Stress



(a) Constant Extension Approximated by a Step-Down Creep Test

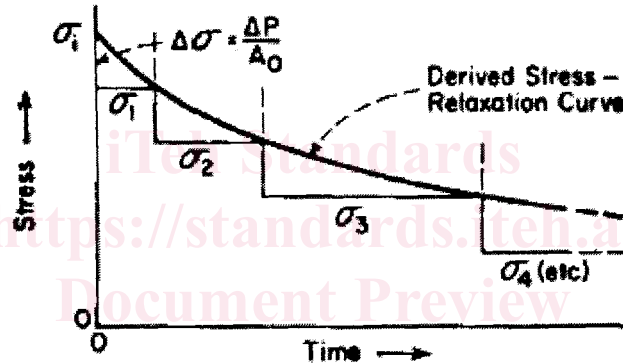

FIG. 4 Derivation of Stress-Relaxation Curve from Continuous Relaxation Technique

7.4 Temperature measurement should be made in accordance with Practice E 139.

## 8. Vibration Control

8.1 Since stress relaxation tests are quite sensitive to shock and vibration, the test equipment and mounting should be located so that the specimen is isolated from vibration.

## 9. Test Specimens

9.1 The test specimens should be of a shape most appropriate for the testing method and end use. Wire may be tested in the “as-received” condition and in the case of metal plate, sheet, strip, bar, or rod, they may be machined to the desired shape.

9.2 Residual stresses may significantly alter the stress relaxation characteristics of the material and care should be exercised in machining to prevent alteration of the residual stresses.

9.3 Specimens for testing must have a uniform cross-section throughout the gage length and meet the following tolerances:

Nominal Diameter or Width	Tolerance, % of Diameter or Width
0.100 in. (2.5 mm)	±0.5
0.250 in. (6.4 mm)	±0.4
0.375 in. (9.5 mm)	±0.3
0.500 in. (12.7 mm)	±0.2

## 10. Environment

10.1 If the test temperature is different from ambient, specimens previously fitted with strain gages or extensometers should be exposed to the test temperature for a period of time sufficient to obtain dimensional stability before starting the tests.

10.2 The stress relaxation test may be started immediately upon achieving thermal equilibrium.

## 11. Guide for Processing Test Data

11.1 The remaining stress, relaxed stress, or load/applied force may be plotted against time or log time. Log stress versus log time plots may also be employed.

11.2 For convenience in comparing the relative relaxation characteristics of materials, the ratio “Fraction Initial Stress Relaxed” may be plotted against time. This ratio is the difference between the initial stress and the remaining stress at any time divided by the initial stress.

## 12. Report

12.1 It is recommended that the report include as much of the following information as is appropriate:

12.1.1 *Material Being Tested:*

12.1.1.1 Chemical composition,

12.1.1.2 Microstructure,

12.1.1.3 Mechanical properties,

12.1.2 Specimen geometry,

12.1.3 Testing machine or apparatus,

12.1.4 Strain measurement method,

12.1.5 Temperature measurement method,

12.1.6 Atmosphere.

12.1.7 *Relaxation Test Data:*

12.1.7.1 Initial stress and strain data,

12.1.7.2 Final stress and strain data,

12.1.7.3 Plot of data.

## A. METHOD FOR CONDUCTING STRESS RELAXATION TENSION TESTS

## 13. Scope

13.1 This test method covers the determination of the time-dependent decrease in stress in a specimen subjected to an uniaxial constant tension strain under conditions of uniform environment and negligible vibration. It also includes recommendations for the necessary testing equipment.

## 14. Summary of Test Method

14.1 The specimen is subjected to an increasing tensile load/force until the specified initial strain is attained. The initial and remaining stresses are determined by either of the methods in 4.1.

## 15. Apparatus

15.1 The testing machine shall have an accuracy of 1 % throughout the working range (see Practices E 4), and should be calibrated under both decreasing and increasing loads/force applications.

15.2 The testing machine shall incorporate means of adjusting the load/force in a continuous and automatic manner in order to maintain constant constraint, so that the strain on the specimen is maintained within  $\pm 0.000025$  in./in. (mm/mm)mm/mm (in./in) (see Fig. 5).

15.3 Axiality of loading force application is extremely important and should be checked using the procedure outlined in Practice E 139/E 1012. Nonaxiality, so measured, should not exceed 15 % in elastic strain readings.

## 16. Test Specimens

16.1 Test specimens of the type, size, and shape described in Test Methods E 8/E 8M and Practice E 139 are generally suitable.

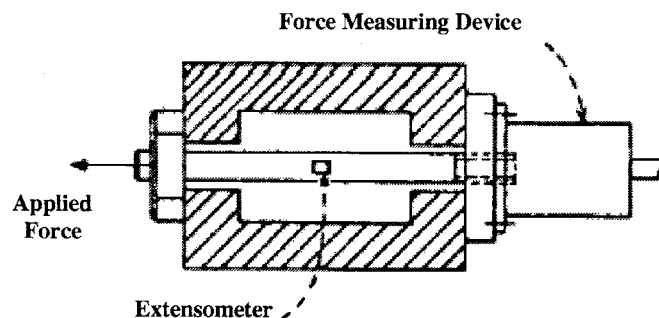

FIG. 5 Tension Stress-Relaxation Test Using Periodic Force Measurement