



Designation: F140 – 98(Reapproved 2008)

## Standard Practice for

# Making Reference Glass-Metal Butt Seals and Testing for Expansion Characteristics by Polarimetric Methods<sup>1</sup>

This standard is issued under the fixed designation F140; the number immediately following the designation indicates the year of original adoption or, in the case of revision, the year of last revision. A number in parentheses indicates the year of last reapproval. A superscript epsilon ( $\epsilon$ ) indicates an editorial change since the last revision or reapproval.

### 1. Scope

1.1 This practice covers the preparation and testing of reference glass-metal butt seals of two general configurations: one applicable to determining stress in the glass and the other to determining the degree of mismatch of thermal expansion (or contraction). Tests are in accordance with Test Method **F218** (Section 1.1).

1.2 This practice applies to all glass and metal (or alloy) combinations normally sealed together in the production of electronic components. It should not be attempted with glass-metal combinations having widely divergent thermal expansion (or contraction) properties.

### 2. Referenced Documents

2.1 *ASTM Standards*:<sup>2</sup>

**F47 Test Method for Crystallographic Perfection of Silicon by Preferential Etch Techniques** (Withdrawn 1998)<sup>3</sup>

**F79 Specification for Type 101 Sealing Glass**

**F105 Specification for Type 58 Borosilicate Sealing Glass**

**F218 Test Method for Measuring Optical Retardation and Analyzing Stress in Glass**

### 3. Summary of Practice

3.1 Five seals of a standard configuration are prepared from representative specimens of the glass and metal to be tested. The glass and metal are cleaned, treated, and sized to specified proportions. Plane-interfaced seals are formed, annealed, and measured for residual optical retardation. The stress parallel to the interface in each seal is calculated from the optical

retardation, and the average stress is computed for the sample. For disk-seals the thermal expansion mismatch is calculated.

### 4. Significance and Use

4.1 The term “reference” as employed in this practice implies that either the glass or the metal of the reference glass-metal seal will be a “standard reference material” such as those supplied for other physical tests by the National Institute for Standards and Technology (NIST), or a secondary reference material whose sealing characteristics have been determined by seals to a standard reference material.<sup>4</sup> Until standard reference materials for seals are established by the NIST, secondary reference materials may be agreed upon between manufacturer and purchaser.

### 5. Apparatus

5.1 *Polarimeter*, as specified in Test Method **F218** for measuring optical retardation and analyzing stress in glass.

5.2 *Cut-Off Saw*, with diamond-impregnated wheel and No. 180 grit abrasive blade under flowing coolant for cutting and fine-grinding glass rod.

5.3 *Glass Polisher*, buffing wheel with cerium oxide polishing powder or laboratory-type equipment with fine-grinding and polishing laps.

5.4 *Heat-Treating and Oxidizing Furnaces*, with suitable controls and with provisions for appropriate atmospheres (Annex A1) for preconditioning metal, if required.

5.5 *Sealing Furnace*, radiant tube, muffle or r-f induction with suitable controls and provision for use with inert atmosphere.

5.6 *Annealing Furnace*, with capability of controlled cooling.

5.7 *Ultrasonic Cleaner*, optional.

5.8 *Fixture for Furnace Sealing*, designed as suggested in Annex A2.

5.9 *Micrometer Caliper*, with index permitting direct reading accuracy of 0.02 cm.

<sup>4</sup> See NIST SP 260.

<sup>1</sup> This practice is under the jurisdiction of ASTM Committee C14 on Glass and Glass Products and is the direct responsibility of Subcommittee C14.04 on Physical and Mechanical Properties.

Current edition approved April 1, 2008. Published December 2008. Originally approved in 1971. Last previous edition approved in 2003 as F140 – 98 (2003). DOI: 10.1520/F0140-98R08.

<sup>2</sup> For referenced ASTM standards, visit the ASTM website, www.astm.org, or contact ASTM Customer Service at service@astm.org. For *Annual Book of ASTM Standards* volume information, refer to the standard's Document Summary page on the ASTM website.

<sup>3</sup> The last approved version of this historical standard is referenced on www.astm.org.

**iTeh Standards**  
**(<https://standards.itih.ai>)**  
**Document Preview**

[ASTM F140-98\(2008\)](#)

<https://standards.itih.ai/catalog/standards/sist/893a6ca7-60ae-47e7-b98d-bf5ff79f5b3/astm-f140-982008>

6. Materials

6.1 *Metal*—Representative specimen pairs of the metal from either rod or plate stock with dimensions satisfying the requirements of 7.2 or 7.3. The surfaces to be sealed should be relatively free of scratches, machine marks, pits, or inclusions that would induce localized stresses. The sealing surfaces should terminate in sharp edges at the peripheral corners to act as a glass stop. Edges that are rounded, such as appear on tumbled parts, will have the tendency to permit glass overflow.

6.2 *Glass*—Representative specimens of rod or plate glass, cut with either diamond-impregnated or other abrasive cutting wheels under flowing water. Dimensions (volume) shall satisfy the requirements of 7.2 or 7.3.

7. Test Specimen

7.1 Two basic cylindrical geometries are considered. For determining only the stress in glass, a seal whose total length is at least twice its diameter must be used. For determining expansion mismatch (as well as stress) a seal whose total thickness is equal to or less than one fifth of its diameter must be used.

7.2 The design for measuring stress provides seals between a cylindrical rod specimen of glass and metal of either rod or sheet (strip) form. The standard rod seal of Fig. 1(a) shall be made from specimens so that the diameter of the metal,  $d_m$  is 0.5 to 1.0 mm larger than the diameter of the glass,  $d_g$ , before the seal is made; the lengths  $l_g$  and  $l_m$  shall each be at least  $d_g$ . The standard sheet seal of Fig. 2(a) shall be made from specimens so that  $l_g$  is at least  $10 l_m$  and  $a$  and  $b$  each exceed  $d_g$  by at least 1.0 mm. In all cases  $d_g$  shall be at least 5.0 mm;  $d$  is defined as the sighting line (or light path) through the glass at the interface after sealing.

7.2.1 Record the dimensions of glass and metal.

7.3 For determining the thermal expansion mismatch between the metal and the glass, the standard disk seal shown in Fig. 3(a) is made. Here  $d_m$  may exceed  $d_g$  by 0.5 to 1.0 mm;  $d_g$  shall be at least 10 mm. The metal to glass thickness ratio,  $t_m/t_g$ , may range from  $1/3$  to 1;  $d$  is defined as the sighting line

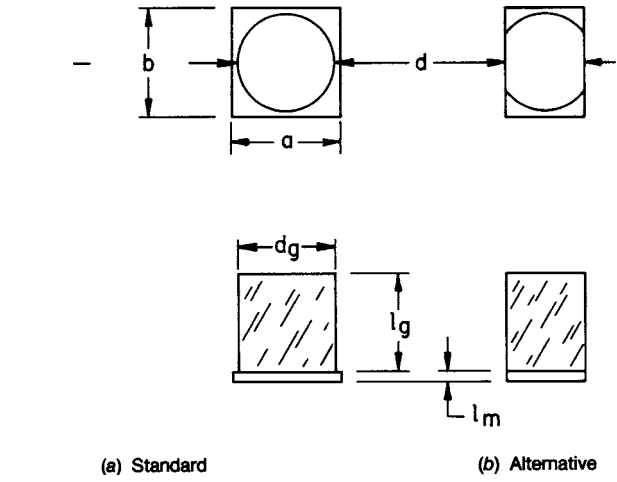

FIG. 2 Sheet Seals

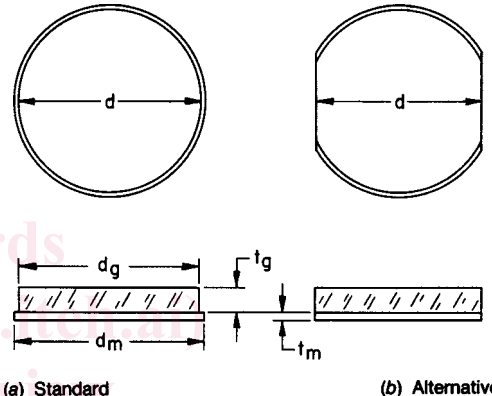

FIG. 3 Disk Seals

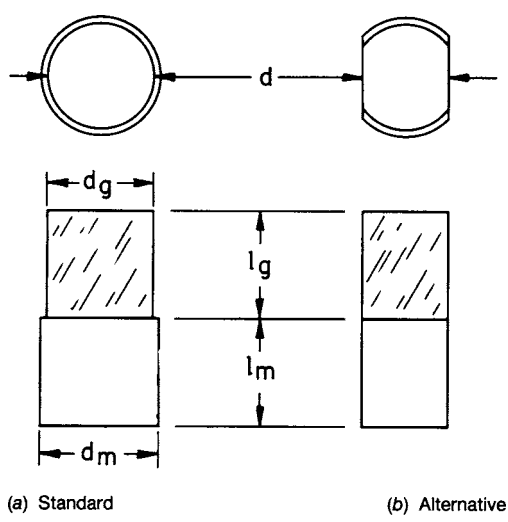

FIG. 1 Rod Seals

(or light path) through the glass at the interface after sealing and must be at least  $5(t_m + t_g)$ .

7.3.1 Record the dimensions of glass and metal.

8. Preparation of Specimens

8.1 *Metal*—Chemically clean the specimens to remove surface contaminants, especially lubricants and fingerprints from fabrication and handling. Usually it is advisable to preoxidize parts as described in Annex A1. Preoxidation promotes a better glass-to-metal bond and relieves cold-working stresses.

NOTE 1—The cleaned and heat-treated metal should be sealed within 24 h and should be protected from surface contamination during this period.

8.2 *Glass*—Using optical-glass techniques grind and polish the sealing surface of the glass specimens with either wet abrasive wheels or water slurries of abrasive on a lap. The polished surface should be at  $90 \pm 2^\circ$  to the specimen axis and without chips, nicks, or scratches. Remove any surface contaminants which could produce bubbly seals. An ultrasonic wash may be used (Annex A1).

8.3 Measure and record the dimensions (diameter, length, thickness) of each glass and each metal specimen.

9. Procedure for Making the Butt-Seal

9.1 Record dimensions of metal plates and glass parts.