**Preskusi mehanskih in fizikalnih lastnosti agregatov - 2. del: Metode določevanja
odpornosti proti drobljenju**

Tests for mechanical and physical properties of aggregates - Part 2: Methods for the
determination of resistance to fragmentation

Prüfverfahren für mechanische und physikalische Eigenschaften von Gesteinskörnungen
- Teil 2: Verfahren zur Bestimmung des Widerstandes gegen Zertrümmerung

Essais pour déterminer les caractéristiques mécaniques et physiques de granulats -
Partie 2 : Méthodes pour la détermination de la résistance à la fragmentation

Ta slovenski standard je istoveten z: prEN 1097-2

ICS:

91.100.15 Mineralni materiali in izdelki Mineral materials and
products

oSIST prEN 1097-2:2018**en,fr,de**

iTeh STANDARD PREVIEW
(standards.iteh.ai)

Full standard:
<https://standards.iteh.ai/catalog/standards/sist/8e7bdda0-a270-408d-9c24-feb0863a3687/sist-en-1097-2-2020>

EUROPEAN STANDARD
NORME EUROPÉENNE
EUROPÄISCHE NORM

DRAFT
prEN 1097-2

January 2018

ICS

Will supersede EN 1097-2:2010

English Version

Tests for mechanical and physical properties of aggregates - Part 2: Methods for the determination of resistance to fragmentation

Essais pour déterminer les caractéristiques
mécaniques et physiques de granulats - Partie 2 :
Méthodes pour la détermination de la résistance à la
fragmentation

Prüfverfahren für mechanische und physikalische
Eigenschaften von Gesteinskörnungen - Teil 2:
Verfahren zur Bestimmung des Widerstandes gegen
Zertrümmerung

This draft European Standard is submitted to CEN members for enquiry. It has been drawn up by the Technical Committee CEN/TC 154.

If this draft becomes a European Standard, CEN members are bound to comply with the CEN/CENELEC Internal Regulations which stipulate the conditions for giving this European Standard the status of a national standard without any alteration.

This draft European Standard was established by CEN in three official versions (English, French, German). A version in any other language made by translation under the responsibility of a CEN member into its own language and notified to the CEN-CENELEC Management Centre has the same status as the official versions.

CEN members are the national standards bodies of Austria, Belgium, Bulgaria, Croatia, Cyprus, Czech Republic, Denmark, Estonia, Finland, Former Yugoslav Republic of Macedonia, France, Germany, Greece, Hungary, Iceland, Ireland, Italy, Latvia, Lithuania, Luxembourg, Malta, Netherlands, Norway, Poland, Portugal, Romania, Serbia, Slovakia, Slovenia, Spain, Sweden, Switzerland, Turkey and United Kingdom.

Recipients of this draft are invited to submit, with their comments, notification of any relevant patent rights of which they are aware and to provide supporting documentation.

Warning : This document is not a European Standard. It is distributed for review and comments. It is subject to change without notice and shall not be referred to as a European Standard.



EUROPEAN COMMITTEE FOR STANDARDIZATION
COMITÉ EUROPÉEN DE NORMALISATION
EUROPÄISCHES KOMITEE FÜR NORMUNG

CEN-CENELEC Management Centre: Rue de la Science 23, B-1040 Brussels

Contents

Page

| | |
|---|-----------|
| European foreword..... | 4 |
| 1 Scope | 6 |
| 2 Normative references | 6 |
| 3 Terms and definitions | 7 |
| 4 Apparatus..... | 8 |
| 4.1 General apparatus | 8 |
| 4.2 Additional apparatus required for determination of resistance to fragmentation by the Los Angeles test method..... | 8 |
| 4.3 Additional apparatus required for determination of resistance to fragmentation by the impact test method..... | 10 |
| 5 Determination of resistance to fragmentation by the Los Angeles test method..... | 10 |
| 5.1 Principle | 10 |
| 5.2 Preparation of test portion..... | 10 |
| 5.3 Test procedure | 11 |
| 5.4 Calculation and expression of results..... | 11 |
| 5.5 Test report..... | 11 |
| 6 Determination of resistance to fragmentation by the impact test method..... | 12 |
| 6.1 Principle | 12 |
| 6.2 Preparation of test specimens..... | 12 |
| 6.3 Test procedure | 13 |
| 6.4 Calculation and expression of results..... | 13 |
| 6.5 Test report..... | 14 |
| Annex A (normative) Determination of resistance to fragmentation of aggregates for railway ballast..... | 15 |
| A.1 Apparatus..... | 15 |
| A.2 Determination of resistance to fragmentation by the Los Angeles test method..... | 17 |
| A.3 Determination of resistance to fragmentation by the impact test method..... | 19 |
| Annex B (informative) Alternative narrow range classifications..... | 21 |
| B.1 Los Angeles test..... | 21 |
| B.2 Impact test | 21 |
| Annex C (informative) The impact tester: Construction, operation and safety requirements..... | 23 |
| C.1 General..... | 23 |
| C.2 Construction..... | 23 |
| C.3 Lifting device..... | 23 |
| C.4 Sample holder..... | 24 |
| C.5 Anvil..... | 25 |
| C.6 Base plate and dampers..... | 25 |

| | | |
|------------------------------|---|-----------|
| C.7 | Safety requirements and testing | 26 |
| C.8 | Checking of impact tester | 26 |
| Annex D (informative) | Checking of the impact tester | 35 |
| D.1 | Scope and field of application | 35 |
| D.2 | Checklist | 35 |
| D.3 | Apparatus and test agents | 35 |
| D.4 | Procedure | 37 |
| Annex E (informative) | Precision | 39 |
| E.1 | General | 39 |
| E.2 | Los Angeles test | 39 |
| E.3 | Impact test | 39 |
| Annex F (informative) | Worked example of calculation of impact value SZ | 40 |
| Annex G (informative) | Alternative narrow range classification for the Los Angeles test of 16/32 mm recycled aggregates | 41 |
| Annex H (informative) | Additional sieve for evaluation of the Los Angeles test for railway ballast | 42 |
| Bibliography | | 43 |

iTeh STANDARD PREVIEW
 (standards.iteh.ai)
 Full standard:
<https://standards.iteh.ai/catalog/standards/sist/8e71bd3a0-9270-408d-9c24-feb0863a3687/sist-en-1097-2-2020>

prEN 1097-2:2018 (E)**European foreword**

This document (prEN 1097-2:2018) has been prepared by Technical Committee CEN/TC 154 “Aggregates”, the secretariat of which is held by BSI.

This document is currently submitted to the CEN Enquiry.

This document will supersede EN 1097-2:2010.

This document has been prepared under a mandate given to CEN by the European Commission and the European Free Trade Association.

The main technical changes compared to EN 1097-2:2010 are the following:

- All annexes are presented in the Scope.
- Guard sieves are introduced in subclause 4.1.2.
- Notes with normative text are transformed into main text or deleted.
- Subclauses 5.5, 6.5, A.2.5 and A.3.5 are revised.
- Annex A is completed to contain full text, not only the parts that are different from the main text.
- Formula (A.1) is revised.
- Annex B is completed with alternative narrow range classifications for the impact test.
- A new Annex H with additional sieves for evaluation of the Los Angeles test for railway ballast is added.
- All references (except for the normative) are dated.
- The Bibliography is supplemented.

This European Standard forms part of a series of tests for mechanical and physical properties of aggregates. Test methods for other properties of aggregates are covered by the following European Standards:

- EN 932, *Tests for general properties of aggregates*
- EN 933, *Tests for geometrical properties of aggregates*
- EN 1367, *Tests for thermal and weathering properties of aggregates*
- EN 1744, *Tests for chemical properties of aggregates*
- EN 13179, *Tests for filler aggregate used in bituminous mixtures*

EN 1097 consists of the following parts, under the general title *Tests for mechanical and physical properties of aggregates*:

- *Part 1: Determination of the resistance to wear (micro-Deval)*
- *Part 3: Determination of loose bulk density and voids*
- *Part 4: Determination of the voids of dry compacted filler*
- *Part 5: Determination of the water content by drying in a ventilated oven*
- *Part 6: Determination of particle density and water absorption*
- *Part 7: Determination of the particle density of filler – Pyknometer method*
- *Part 8: Determination of the polished stone value*
- *Part 9: Method for the determination of the resistance to wear by abrasion from studded tyres — Nordic test*
- *Part 10: Water suction height*
- *Part 11: Determination of compressibility and confined compressive strength of lightweight aggregates*

iTeh STANDARD PREVIEW
(standards.iteh.ai)
Full standard:
<https://standards.iteh.ai/catalog/standards/sist/8e71b2a0-a270-408d-9c24-feb0863a3687/sist-en-1097-2-2020>

prEN 1097-2:2018 (E)**1 Scope**

This European Standard describes the reference method, the Los Angeles test, used for type testing and in case of dispute (and an alternative method, the impact test) for determining the resistance to fragmentation of coarse aggregates (main text) and aggregates for railway ballast (Annex A). For other purposes, in particular factory production control, other methods are possible provided that an appropriate working relationship with the reference method has been established.

This European Standard applies to natural, manufactured or recycled aggregates used in building and civil engineering.

Annex A describes a method for the determination of resistance to fragmentation of aggregates for railway ballast.

Annex B gives alternative narrow range classifications for the Los Angeles test and the impact test.

Annex C contains construction, operation and safety requirements for the impact tester.

Annex D describes a method for checking of the impact tester.

Annex E gives precision data.

Annex F contains a worked example of calculation of impact value SZ.

Annex G gives an alternative narrow range classification for the Los Angeles test of 16/32 mm recycled aggregates.

Annex H proposes additional sieves for the evaluation of the Los Angeles test for railway ballast.

Annex A is normative and Annexes B to H are informative.

2 Normative references

The following documents are referred to in the text in such a way that some or all of their content constitutes requirements of this document. For dated references, only the edition cited applies. For undated references, the latest edition of the referenced document (including any amendments) applies.

EN 932-2, *Tests for general properties of aggregates - Part 2: Methods for reducing laboratory samples*

EN 932-5, *Tests for general properties of aggregates - Part 5: Common equipment and calibration*

EN 933-1, *Tests for geometrical properties of aggregates - Part 1: Determination of particle size distribution - Sieving method*

EN 933-2, *Tests for geometrical properties of aggregates - Part 2: Determination of particle size distribution - Test sieves, nominal size of apertures*

EN 1097-6, *Tests for mechanical and physical properties of aggregates - Part 6: Determination of particle density and water absorption*

EN 10025-2:2004, *Hot rolled products of structural steels - Part 2: Technical delivery conditions for non-alloy structural steels*

3 Terms and definitions

For the purposes of this document, the following terms and definitions apply.

ISO and IEC maintain terminological databases for use in standardization at the following addresses:

- IEC Electropedia: available at <http://www.electropedia.org/>
- ISO Online browsing platform: available at <http://www.iso.org/obp>

3.1

constant mass

mass determined after successive weighings at least 1 h apart not differing by more than 0,1 %

Note 1 to entry: In many cases constant mass can be achieved after a test portion has been dried for a pre-determined period in a specified oven (see 4.1.4) at (110 ± 5) °C. Test laboratories can determine the time required to achieve constant mass for specific types and sizes of sample dependent upon the drying capacity of the oven used.

3.2

impact value

SZ

value which gives a measure of the resistance of aggregates to dynamic crushing; it is equal to one fifth of the sum of the mass percentages of the tested sample passing through five specified test sieves when tested in accordance with Clause 6.

3.3

laboratory sample

sample intended for laboratory testing

3.4

Los Angeles coefficient

LA

percentage of the test portion passing a pre-determined sieve after completion of the test

3.5

test portion

sample used as a whole in a single test

3.6

test specimen

sample used in a single determination when a test method requires more than one determination of a property

4 Apparatus

Unless otherwise stated, all apparatus shall conform to the general requirements of EN 932-5.

4.1 General apparatus

4.1.1 **Test sieves**, conforming to EN 933-2 with aperture sizes as specified in Table 1.

Table 1 — Test sieves

| Test | Aperture size mm |
|---|------------------------------------|
| Los Angeles | 1,6; 10; 11,2 (or 12,5); 14 |
| Impact test ^a | 0,2; 0,63; 2; 5; 8; 10; 11,2; 12,5 |
| For alternative narrow range classifications other sieves can be used (see Annex B). | |
| ^a For the impact test, because of the tolerances in the sieve openings, the same 8 mm test sieve used for the preparation of the test portion should again be used for the evaluation of the test. | |

4.1.2 **Guard sieve**, e.g. 2 mm, 4 mm or 8 mm.

4.1.3 **Balance**, capable of weighing the test portion to an accuracy of 0,1 % of the mass of the test portion.

4.1.4 **Ventilated oven**, controlled to maintain a temperature of (110 ± 5) °C.

4.1.5 **Brush and bowls**.

4.2 Additional apparatus required for determination of resistance to fragmentation by the Los Angeles test method

4.2.1 **Equipment**, for reducing the laboratory sample to a test portion, as described in EN 932-2.

4.2.2 **Los Angeles test machine**, comprising the following essential parts.

NOTE An example of a machine that has been found to be satisfactory is shown in Figure 1.

Dimensions in millimetres

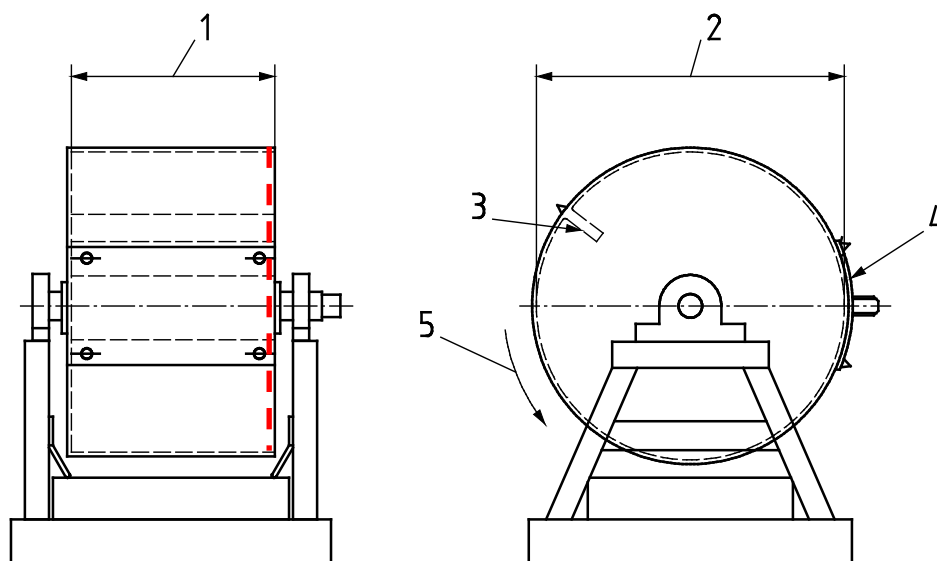
**Key**

- 1 internal length (508 ± 5)
- 2 internal diameter (711 ± 5)
- 3 shelf
- 4 cover and opening
- 5 rotation
- 6 tray

Figure 1 – Typical Los Angeles testing machine

4.2.2.1 Hollow drum, made of structural steel plate ($12^{+10}_{-0.5}$) mm thick conforming to grade S275 of EN 10025-2:2004 which has been selected to be formed without undue stress, and can be welded without significant distortion. The drum shall be closed at both ends. It shall have an internal diameter of (711 ± 5) mm and an internal length of (508 ± 5) mm. The drum shall be supported on two horizontal stub axles fixed to its two end walls but not penetrating inside the drum; the drum shall be mounted so that it rotates about a horizontal axis.

An opening (150 ± 3) mm wide shall be provided, preferably over the whole length of the drum, to facilitate insertion and removal of the sample after the test. During the test, the opening shall be sealed so that it is dustproof, by using a removable cover which enables the inside surface to remain cylindrical.

The cylindrical inner surface shall be interrupted by a projecting shelf, placed between 380 mm and 820 mm from the nearest edge of the opening. The distance shall be measured along the inside of the drum in the direction of rotation. The shelf shall have a rectangular cross section (length equal to that of the drum, width (90 ± 2) mm, thickness (25 ± 1) mm) and it shall be placed in a diametrical plane, along a generating line, and shall be rigidly fixed in place.

The shelf shall be replaced when its width at any point wears to less than 86 mm and its thickness at any point along the front edge wears to less than 23 mm.

The base of the machine shall be supported directly on a level concrete or stone block floor.

The removable cover should be made of the same steel as the drum. The projecting shelf should be made of the same steel or a harder grade.

prEN 1097-2:2018 (E)

4.2.2.2 Ball load, consisting of 11 spherical steel balls. Each ball shall weigh between 400 g and 445 g, and the total load shall weigh between 4 690 g and 4 860 g.

NOTE 1 The approximate diameter of balls is 47 mm.

NOTE 2 The nominal mass of the charge with new balls is 4 840 g. A positive tolerance of 20 g allows for manufacturing variation and a negative tolerance of 150 g allows for ball wear in use.

NOTE 3 A hardness of the steel balls between HRC 60 and HRC 66 is suitable (as specified in EN ISO 6508-1:2016).

4.2.2.3 Motor, imparting a rotational speed to the drum of between 31 r/min and 33 r/min.

4.2.2.4 Tray, for recovering the material and the ball load after testing.

4.2.2.5 Revolution counter, which will automatically stop the motor after the required number of revolutions.

4.3 Additional apparatus required for determination of resistance to fragmentation by the impact test method

4.3.1 Impact tester, see Annex C.

4.3.2 Equipment for testing the accuracy of the impact tester, see Annex D.

5 Determination of resistance to fragmentation by the Los Angeles test method

5.1 Principle

A sample of aggregate is rolled with steel balls in a rotating drum. After rolling is complete, the quantity of material retained on a 1,6 mm sieve is determined.

5.2 Preparation of test portion

A laboratory sample shall be obtained in accordance with EN 932-2. The mass of the laboratory sample shall have at least 15 kg of particles in the 10 mm to 14 mm size range.

The test shall be carried out on aggregate passing the 14 mm test sieve and retained on the 10 mm test sieve. In addition, the grading of the test portion shall comply with at least one of the following requirements:

- a) between 60 % and 70 % passing a 12,5 mm test sieve;
- b) between 30 % and 40 % passing a 11,2 mm test sieve.

NOTE 1 The additional grading requirements allow the test portion to be created from aggregate sizes other than 10/14 mm (see Annex B).

NOTE 2 For recycled aggregates, a test procedure for the 16/32 mm size fraction is described in Annex G. Table G.1 will be completed in the future with additional sizes if needed.

Sieve the laboratory sample using the 10 mm, 11,2 mm (or 12,5 mm) and 14 mm test sieves to give separate fractions in the ranges 10 mm to 11,2 mm (or 12,5 mm) and 11,2 mm (or 12,5 mm) to 14 mm.