



Standard Test Method for Determining the Corrosive Effect of Combustion Products Using the Cone Corrosimeter¹

This standard is issued under the fixed designation D 5485; the number immediately following the designation indicates the year of original adoption or, in the case of revision, the year of last revision. A number in parentheses indicates the year of last reapproval. A superscript epsilon (ϵ) indicates an editorial change since the last revision or reapproval.

1. Scope

1.1 This fire-test-response standard measures the corrosive effect by loss of metal from the combustion products of materials, components, or products.

1.2 This test method provides corrosion results of product and material specimens limited to a maximum size of 100 by 100 mm in area and 50 mm thick.

1.3 The results of this test method have not been investigated with respect to correlation to actual fires.

1.4 *This standard measures and describes the response of materials, products, or assemblies to heat and flame under controlled conditions, but does not by itself incorporate all factors required for fire hazard or fire risk assessment of the materials, products, or assemblies under actual fire conditions.*

1.4.1 Additional information regarding the targets, the test conditions, and test limitations are provided in the annex.

1.5 *This standard does not purport to address all of the safety concerns, if any, associated with its use. It is the responsibility of the user of this standard to establish appropriate safety and health practices and determine the applicability of regulatory limitations prior to use.* For specific hazard statements, see Section 7.

1.6 The values stated in SI units are the standard (see IEEE/ASTM SI 10).

2. Referenced Documents

2.1 ASTM Standards:

D 618 Practice for Conditioning Plastics for Testing²

D 1711 Terminology Relating to Electrical Insulation³

E 176 Terminology of Fire Standards⁴

E 1354 Test Method for Heat and Visible Smoke Release Rates for Materials and Products Using an Oxygen Consumption Calorimeter⁴

IEEE/ASTM SI-10 Standard for Use of the International System of Units (SI): The Modern Metric System⁵

2.2 Other Document:

OSHA 191.1450 Occupational Exposure to Hazard Chemicals in Laboratories⁶

3. Terminology

3.1 Definitions:

3.1.1 For definitions of terms used in this test method, refer to Terminologies E 176 and D 1711.

3.2 Definitions of Terms Specific to This Standard:

3.2.1 *cone corrosimeter, n*—equipment used to determine corrosion in this test method.

3.2.2 *corrosion-by-metal-loss, n*—loss of metal of a target expressed as reduction of thickness of the target metal.

3.2.3 *exposure chamber, n*—enclosure in which a target is exposed to combustion products.

3.2.4 *heating flux, n*—incident power per unit area that is imposed externally from the heater on the specimen.

3.2.4.1 *Discussion*—The specimen, once ignited, is also heated by its own flame.

3.2.5 *sustained flaming, n*—existence of flame on or over the surface of the specimen for periods of 4 s or more.

3.2.5.1 *Discussion*—Flaming ignition of less than 4 s is identified as transitory flaming or flashing.

3.2.6 *target, n*—detector of known electrical resistance which can lose metal through a process of corrosion when it is exposed to combustion products.

3.3 Symbols Specific to This Standard:

3.3.1 A_0 —initial corrosion instrument reading.

3.3.2 A_1 —corrosion instrument reading at the end of 1-h exposure to combustion products.

3.3.3 A_{24} —corrosion instrument reading at the end of 24 h in the environmental chamber.

3.3.4 C —corrosion of a target, nm.

3.3.5 C_1 —corrosion at the end of 1-h exposure to combustion products, nm.

3.3.6 C_{24} —corrosion at the end of 24 h in the environmental chamber, nm.

¹ This test method is under the jurisdiction of ASTM Committee D09 on Electrical and Electronic Insulating Materials and is the direct responsibility of Subcommittee D09.21 on Fire Performance Standards.

Current edition approved Oct. 10, 1999. Published December 1999. Originally published as D 5485 – 94. Last previous edition D 5485 – 94a.

² *Annual Book of ASTM Standards*, Vol 08.01.

³ *Annual Book of ASTM Standards*, Vol 10.01.

⁴ *Annual Book of ASTM Standards*, Vol 04.07.

⁵ *Annual Book of ASTM Standards*, Vol 14.02.

⁶ Available from Occupational Safety and Health Agency.

- 3.3.7 m —specimen mass, g.
- 3.3.8 m_f —final specimen mass, g.
- 3.3.9 m_i —initial specimen mass, g.
- 3.3.10 m_{70} —average 70 % of the total mass loss, g.
- 3.3.11 t_d —sampling time, s.
- 3.3.12 T_c —temperature of the gas in the exposure chamber, °C.
- 3.3.13 V —volumetric sampling rate of combustion products, m³/s.

4. Summary of Test Method

4.1 In this test method, a specimen is subjected to radiant heat. A spark igniter is used to ignite the combustible vapors. The products of decomposition or combustion are channeled through a funnel. A portion of the products continuously flows through an exposure chamber which holds the corrosion targets until the specimen has lost an average 70 % of the total combustible mass or for a period of 60 min, whichever is less. The corrosion of the target is determined by exposure of the target to combustion products for 1 h, followed by 24-h exposure of the target to a controlled humidity and temperature environment in a separate chamber. The increase in electrical resistance of each target is monitored, and the reduction in thickness of the metal on the target is calculated from the increase in electrical resistance. This reduction in thickness is referred to as corrosion-by-metal-loss.

4.2 This test method involves the use of a cone calorimeter as described in Section 7 and shown in Fig. 1.

4.3 Alternate equipment found suitable for this test method is the cone calorimeter (see Test Method E 1354), with the addition of the gas sampling system described in this test method.

5. Significance and Use

5.1 The metal loss from corrosion is directly related to the increase in electrical resistance of the target due to the decrease in conductive cross-sectional area.

5.2 The relationship between resistance increase of metallic targets used in this test method and the amount of metal loss as reported by a uniform loss in thickness has not been determined.

5.3 This test method is used to determine the corrosive effect of combustion products from burning electrical insulations or coverings or their constituent materials or components. Corrosion is determined by the reduction of thickness of the metal on standardized targets, as measured by electrical resistance. These targets are not necessarily representative of the intended end use.

5.4 This test method is intended for use in electrical insulations or coverings material and product evaluations, for additional data to assist in design of electrical insulations or coverings products, or for development and research of electrical insulations or coverings products.

5.5 A value of the heating flux is selected to be relevant to the fire scenario being investigated (up to 100 kW/m²). Additional information for testing is given in A1.2.3.

6. Interferences

6.1 Discard the test data if any of the following occur:

6.1.1 Leakage occurs between the sampling point and the exit of the exposure chamber which could cause a dilution of gases.

6.1.2 The specimen swells sufficiently prior to ignition to touch the spark plug or swells into the plane of the heater base plate during combustion.

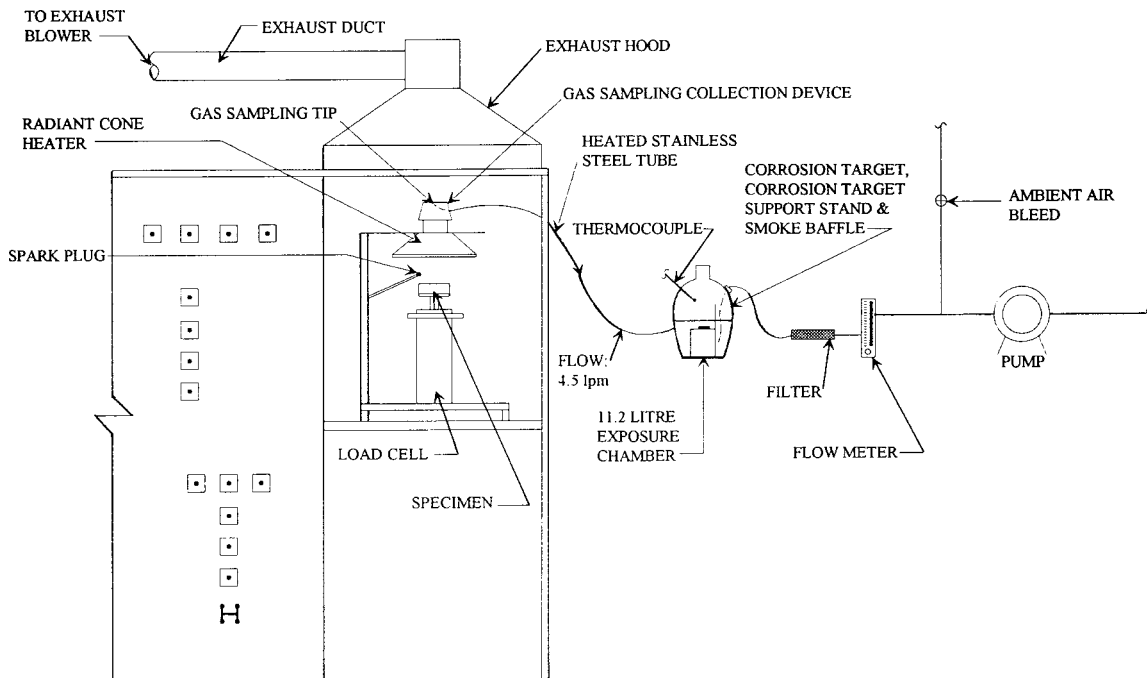

FIG. 1 Cone Corrosimeter

6.1.3 The specimen drips off the specimen holder or falls out of the specimen holder such that the specimen is not subjected to the test exposure conditions.

6.1.4 There is highly localized corrosion of the target, indicating a defective target.

6.1.5 There is visual degradation of the reference circuit by the attack of combustion products on or under the protective coating.

7. Apparatus

7.1 General:

7.1.1 This test method uses the cone calorimeter described in 7.1.3. Alternatively, the cone calorimeter test equipment is acceptable provided that it is equipped with a gas sampling system as described in 7.8.

7.1.2 The dimensions of the cone calorimeter specimen holder and additional equipment used in collection of gas samples are given in Figs. 1-8 and also stated in the following description.

7.1.3 The cone calorimeter consists of the following main components: conical-shaped radiant electric heater; temperature controller; load cell; electric ignition spark plug; heat-flux gage; exhaust system; specimen holder; and the gas sampling system. Other essential elements needed to measure corrosion are a corrosion target and a device to measure corrosion (see 7.9). A general view of the cone calorimeter is shown in Fig. 1.

7.2 Conical Heater:

7.2.1 The active element of the heater consists of an electrical heater rod, rated at 5000 W at 240 V, tightly wound into the shape of a truncated cone (Fig. 2). The heater is encased on the outside with a double-wall stainless steel cone, and packed with a refractory fiber material of approximately 100-kg/m³ density.

7.2.2 The heater is capable of producing heating flux on the surface of the specimen of up to 100 kW/m² with a uniformity of ± 2 % within the central 50 by 50-mm area of the specimen.

7.2.3 The heating flux from the heater is held at a preset level by means of a temperature controller and three Type K

stainless-steel-sheathed thermocouples having an outside diameter of 1.5 to 1.6 mm with an unexposed hot junction. Alternatively, either 3-mm outside diameter sheathed thermocouples with an exposed hot junction, or 1-mm outside diameter sheathed thermocouples with an unexposed hot junction are suitable. They are symmetrically disposed and in contact with, but not welded to, the heater element (see Fig. 2). The thermocouples are of equal length and wired in parallel to the temperature controller.

7.3 Temperature Controller:

7.3.1 The temperature controller for the heater is to hold the element temperature steady to within ±2°C. A suitable temperature controller system is a “3-term” controller (proportional, integral, and derivative) with a thyristor unit capable of switching currents up to 25 A at 240 V.

7.3.2 The controller has a temperature input range from 0 to 1000°C; a set scale with a resolution of 2°C; and automatic cold junction compensation. The controller is equipped with a safety feature such that in the event of an open circuit in the thermocouple line, it will cause the temperature to fall to near the bottom of its range.

7.3.3 The temperature controller uses a zero-crossing-type thyristor unit.

7.3.4 The heater temperature is monitored by a meter with a resolution of 2°C.

7.4 Exhaust System:

7.4.1 The exhaust-gas system consists of a high-temperature centrifugal exhaust blower, a hood, intake and exhaust ducts for the fan, and an orifice plate flowmeter (Fig. 3).

7.4.2 The flow rate is determined by measuring the differential pressure across a sharp-edged orifice (57-mm inside diameter) in the exhaust stack, at least 350 mm downstream from the fan.

7.4.3 In other details, the geometry of the exhaust system is not critical. Where necessary, small deviations from the recommended dimensions given in Fig. 3 are allowed. For example, it is permissible for the inner diameter of the duct and the orifice plate to be slightly different (tolerance: ±2 mm).

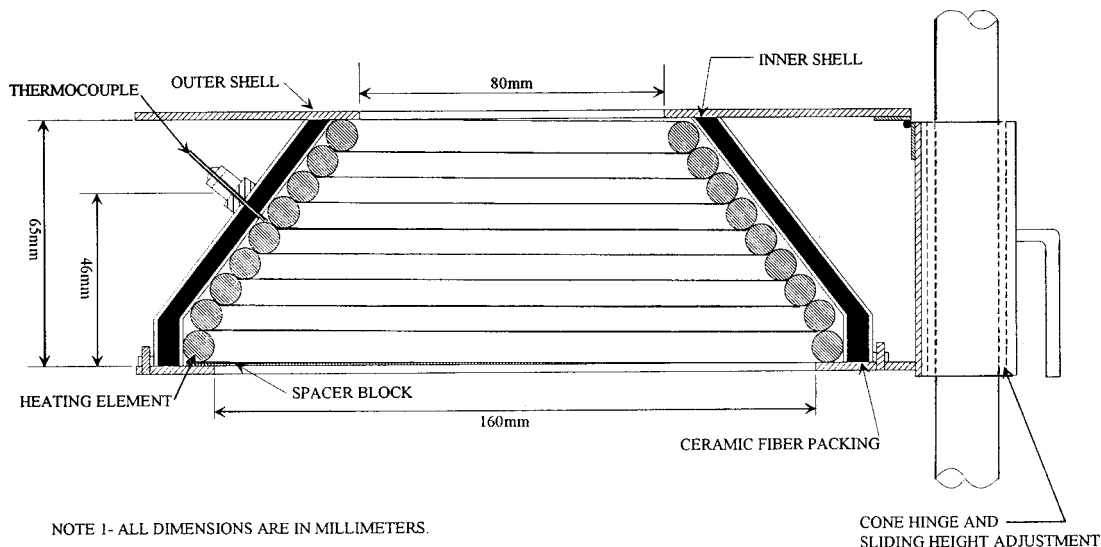
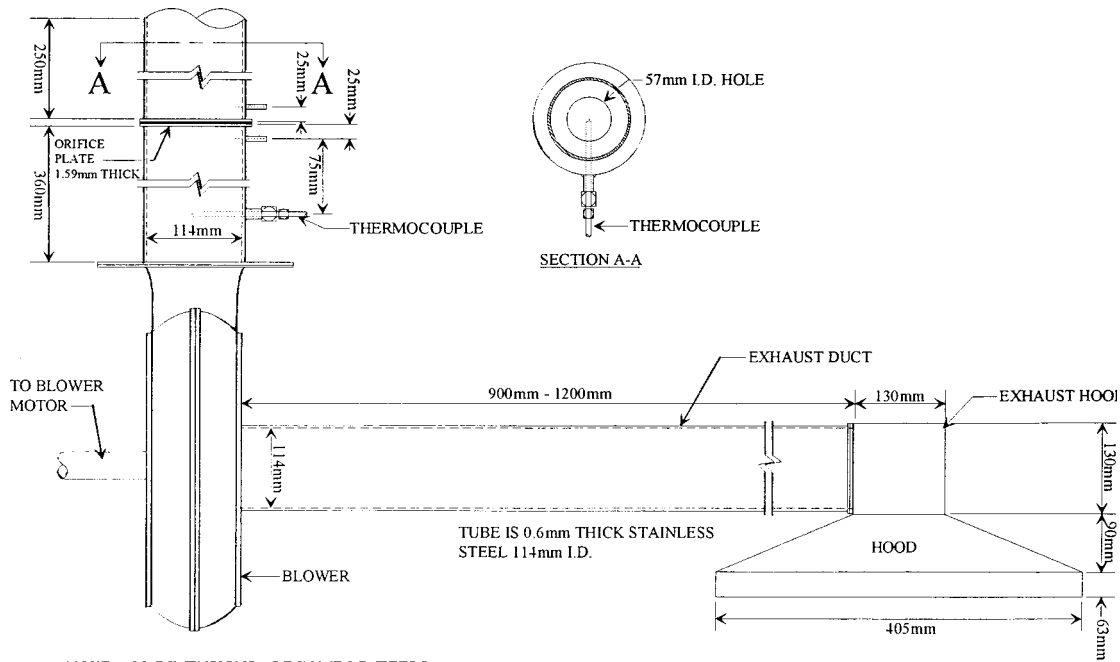

FIG. 2 Cross-Section View Through the Heater



NOTE: ALL DIMENSIONS ARE IN MILLIMETERS

FIG. 3 Exhaust System

LOAD CELL AND CONE RADIANT HEATER

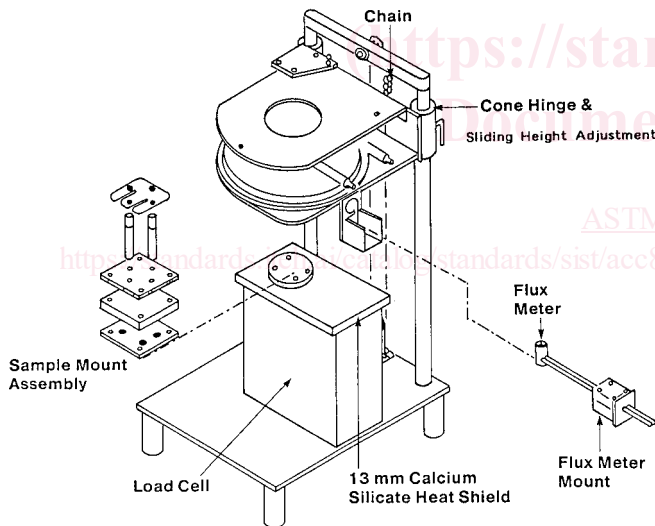

FIG. 4 Exploded View of Load Cell and Cone Radiant Heater

The location of the fan in Fig. 3 shall be between 900 and 1200 mm downstream of the hood. Flow through the fan ensures adequate mixing, which is essential to the test.

7.5 *Load Cell*—The general arrangement of the load cell with the conical heater is shown in Fig. 4. Use a load cell with an accuracy of 0.1 g, a measuring range of at least 500 g, and a mechanical tare adjustment range of 3.5 kg.

7.6 *Specimen Holder and Mounting:*

7.6.1 A specimen holder consists of the bottom, the edge frame, retaining pins, and wire grid as shown in Fig. 5. The bottom is constructed from 2-mm nominal stainless steel and has outside dimensions of 111 by 111 by 24-mm height (± 2 mm). The grid is constructed from 1-mm nominal stainless

steel and has dimensions of 109 by 109 mm (± 2 mm). The grid has 1-mm ribs and the openings in the center are 19 by 19 mm (± 1 mm). The edge frame is constructed from 2-mm nominal stainless steel with outside dimensions of 116 by 116 by 56-mm height (± 2 mm). The frame has an 8-mm lip on the top to provide an opening of 100 by 100 mm on the top. There are two 3-mm (± 0.5 mm) diameter by 130-mm (± 3 mm) long retaining pins to lock the test specimen in the edge frame.

7.6.2 The bottom is lined with a layer of a low-density (nominal density 65 kg/m³) refractory fiber blanket with thickness of at least 13 mm.⁷ The distance between the bottom of the radiant heater and the top of the edge frame is adjusted to 25 \pm 1 mm by using the sliding height adjustment (Fig. 2).

7.7 *Ignition Circuit:*

7.7.1 External ignitor is a spark plug powered from a 10-kV transformer. The spark plug has a gap of 3 mm. The transformer is of a type specifically designed for spark-ignition use. The transformer has an isolated (ungrounded) secondary to minimize interference with the data-transmission lines. The electrode length and location of the spark plug is such that the spark gap is located 13 mm above the center of the specimen.

7.8 *Gas Sampling System:*

7.8.1 The gas sampling system consists of a conical funnel, stainless steel tubing, electric heating tape, silicone rubber tubing, filter, flowmeter, exposure chamber, target support stand, and pump. The general arrangement of the gas sampling system is shown in Fig. 1.

7.8.2 *Funnel*—The funnel is a truncated cone constructed from stainless steel having a larger diameter of 173 \pm 5 mm, a smaller diameter of 60 \pm 5 mm, and a height of 97 \pm 5 mm.

⁷ A refractory blanket, RT8 ceramic fiber, Cer-Wool, manufactured by Premier Refractories and Chemicals, Inc., King of Prussia, PA, is suitable for this application.

MATERIAL:

STAINLESS 1.84mm THICK

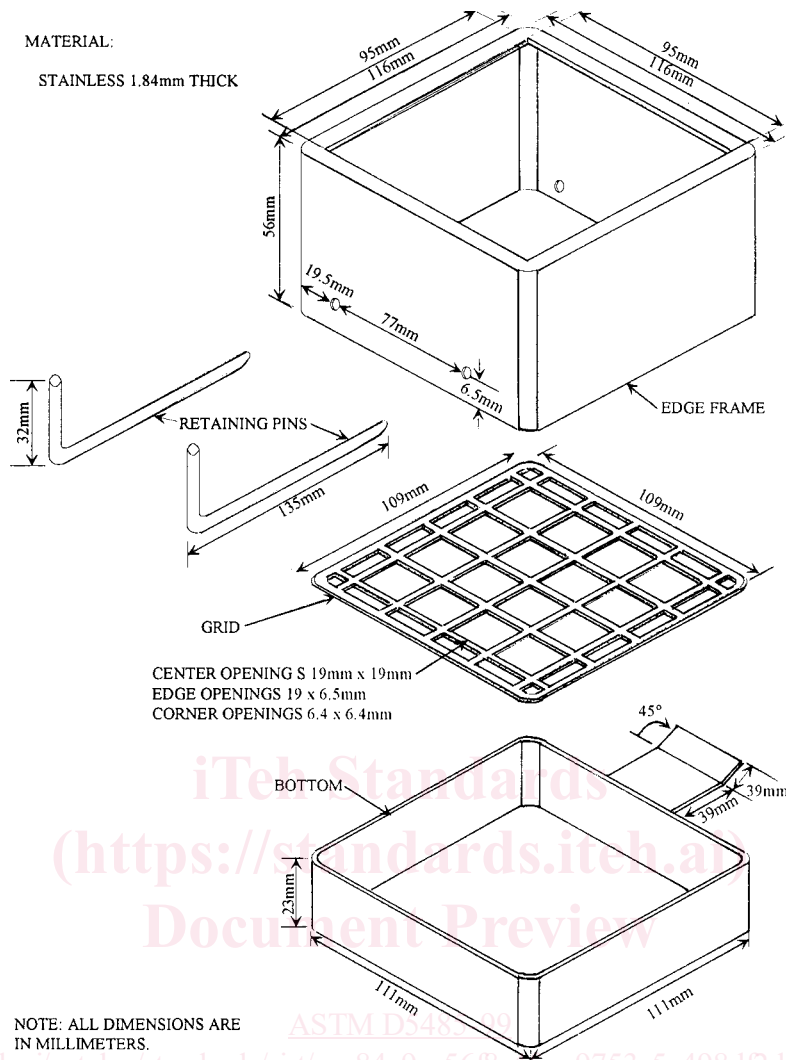

FIG. 5 Specimen Holder

It stands on 57 ± 5 -mm legs projecting from the larger diameter end. The funnel is shown in Fig. 6.

7.8.3 *Rigid Tubing*—A 6.3-mm (0.25-in.) outside diameter by 675 ± 75 -mm long stainless steel tube draws a gas sample from the combustion stream. One end of the tube is bent with the open end of the tube facing away from the specimen surface. The end of the tube is 255 ± 10 mm from the specimen surface. The other end of the rigid tube is connected to flexible tubing. The arrangement of the rigid tube with the funnel is shown in Fig. 6.

7.8.4 *Electric Heating Tape*⁸—Electric heating tape is used to maintain a minimum temperature of the rigid tubing.

7.8.5 *Flexible Tubing*—The flexible tubing⁹ consists of 6.3-mm inside diameter by 255 ± 10 -mm long silicone rubber tube. The flexible tubing is used to connect the rigid tubing to the exposure chamber.

7.8.6 *Exposure Chamber*—The exposure chamber consists of a 0.0112 ± 0.0005 -m³ polycarbonate chamber,¹⁰ a corrosion probe support stand, and smoke baffle. The chamber has an O-ring seal and inlet and outlet ports. The corrosion chamber is shown in Fig. 7.

7.8.7 *Target Support Stand and Smoke Baffle*—The target support stand and smoke baffle (Fig. 8) is fabricated from polycarbonate material 3 mm thick. The bottom component is formed to the dimensions as shown from a single sheet of material. Each of the bottom horizontal flanges, vertical legs, and the horizontal ledge (refer to the front view of Fig. 8) are formed by heating the polycarbonate material and bending the sheet into the geometry as shown. The smoke baffle is cut to the dimensions shown and glued to the bottom with an adhesive.

7.9 *Corrosion Target and Instrumentation*:

7.9.1 *Corrosion Target*—A target is composed of two circuit elements. One circuit element is unprotected and is used for measuring corrosion. The other circuit, with a protective

⁸ Cole-Parmer Instrument Co., Model 03110-20 (1-in. wide) is suitable for this purpose.

⁹ Silicone rubber flexible tubing from Cole-Parmer Instrument Co., Part No. L06411-72 is suitable.

¹⁰ Cole-Parmer-polycarbonate dessicator, Part No. L-06520-05 is suitable for this purpose.

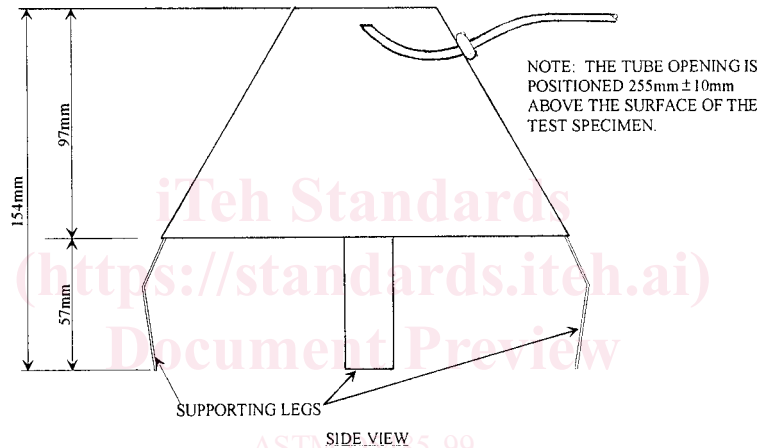
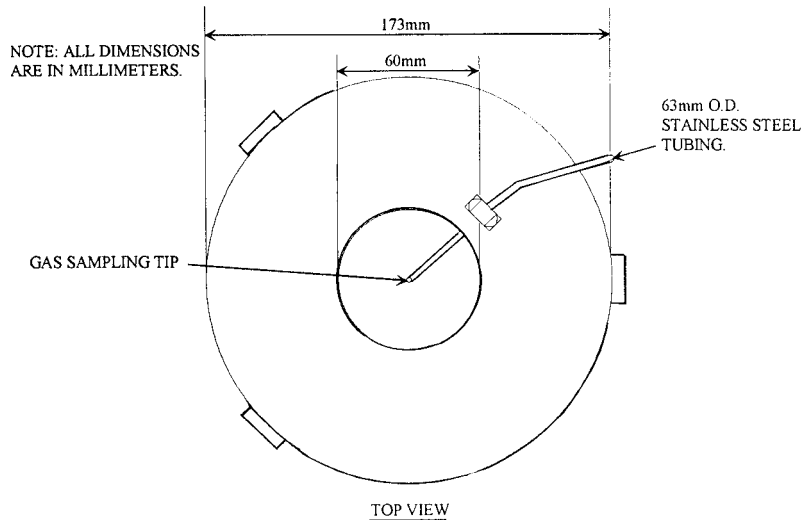

FIG. 6 Gas Sampling Collection Device

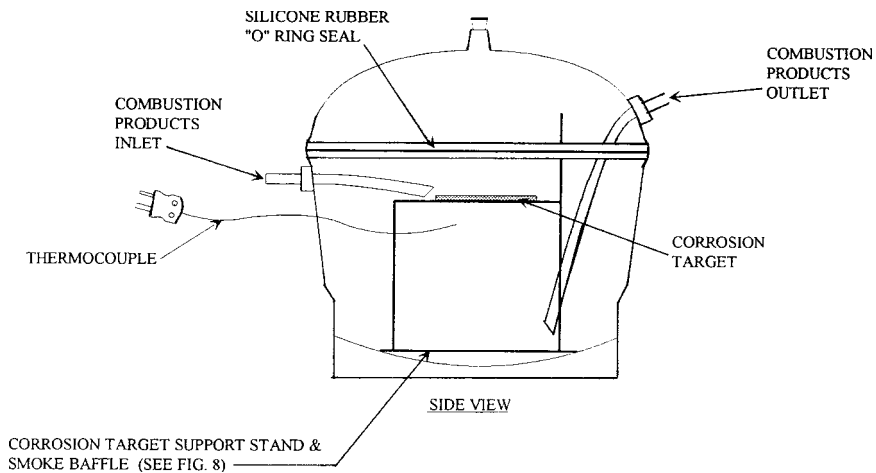

FIG. 7 11.2-L Exposure Chamber

coating, is used as a reference. This compensates for change in electrical resistance due to change in temperature. Both ele-

ments of the target are part of a bridge circuit and are exposed to combustion products.