**Rubber, vulcanized or thermoplastic —
Determination of tendency to adhere
to and corrode metals**

*Caoutchouc, vulcanisé ou thermoplastique — Détermination de la
tendance à adhérer aux métaux et à les corroder*

iTeh STANDARD PREVIEW
(standards.iteh.ai)

[ISO 6505:2015](https://standards.iteh.ai/catalog/standards/sist/583c4426-9d39-4af3-901c-abcbbf6f57ef/iso-6505-2015)

[https://standards.iteh.ai/catalog/standards/sist/583c4426-9d39-4af3-901c-
abcbbf6f57ef/iso-6505-2015](https://standards.iteh.ai/catalog/standards/sist/583c4426-9d39-4af3-901c-abcbbf6f57ef/iso-6505-2015)



iTeh STANDARD PREVIEW
(standards.iteh.ai)

[ISO 6505:2015](https://standards.iteh.ai/catalog/standards/sist/583c4426-9d39-4af3-901c-abcbbf6f57ef/iso-6505-2015)

<https://standards.iteh.ai/catalog/standards/sist/583c4426-9d39-4af3-901c-abcbbf6f57ef/iso-6505-2015>



COPYRIGHT PROTECTED DOCUMENT

© ISO 2015

All rights reserved. Unless otherwise specified, no part of this publication may be reproduced or utilized otherwise in any form or by any means, electronic or mechanical, including photocopying, or posting on the internet or an intranet, without prior written permission. Permission can be requested from either ISO at the address below or ISO's member body in the country of the requester.

ISO copyright office
Case postale 56 • CH-1211 Geneva 20
Tel. + 41 22 749 01 11
Fax + 41 22 749 09 47
E-mail copyright@iso.org
Web www.iso.org

Published in Switzerland

Contents

Page

Foreword	iv
Introduction	v
1 Scope	1
2 Normative references	1
3 Principle	1
4 Materials	1
5 Apparatus	2
6 Test metals	2
7 Calibration	4
8 Test pieces	4
8.1 Preparation.....	4
8.1.1 Square test pieces.....	4
8.1.2 O-ring test pieces.....	4
8.2 Number.....	4
8.3 Time-interval between forming the material and testing.....	4
8.4 Storage.....	4
9 Test conditions	4
9.1 Temperature.....	4
9.2 Test period.....	5
9.3 Humidity.....	5
10 Procedure	5
10.1 Precaution.....	5
10.2 Preparation of rubber test pieces for testing.....	5
10.3 Number of metal test strips.....	5
10.4 Preparation of surfaces of metal test strips.....	5
10.5 Determination.....	6
10.5.1 Tests in a dry atmosphere.....	6
10.5.2 Tests in a wet atmosphere.....	6
11 Expression of results	7
11.1 Degree of adhesion.....	7
11.2 Degree of corrosion.....	7
11.2.1 For tests in a dry atmosphere.....	7
11.2.2 For tests in a wet atmosphere.....	8
12 Test report	8
Annex A (normative) Calibration schedule	9
Annex B (informative) Grading of degree of corrosion	11

Foreword

ISO (the International Organization for Standardization) is a worldwide federation of national standards bodies (ISO member bodies). The work of preparing International Standards is normally carried out through ISO technical committees. Each member body interested in a subject for which a technical committee has been established has the right to be represented on that committee. International organizations, governmental and non-governmental, in liaison with ISO, also take part in the work. ISO collaborates closely with the International Electrotechnical Commission (IEC) on all matters of electrotechnical standardization.

The procedures used to develop this document and those intended for its further maintenance are described in the ISO/IEC Directives, Part 1. In particular the different approval criteria needed for the different types of ISO documents should be noted. This document was drafted in accordance with the editorial rules of the ISO/IEC Directives, Part 2 (see www.iso.org/directives).

Attention is drawn to the possibility that some of the elements of this document may be the subject of patent rights. ISO shall not be held responsible for identifying any or all such patent rights. Details of any patent rights identified during the development of the document will be in the Introduction and/or on the ISO list of patent declarations received (see www.iso.org/patents).

Any trade name used in this document is information given for the convenience of users and does not constitute an endorsement.

For an explanation on the meaning of ISO specific terms and expressions related to conformity assessment, as well as information about ISO's adherence to the WTO principles in the Technical Barriers to Trade (TBT) see the following URL: [Foreword - Supplementary information](#)

The committee responsible for this document is ISO/TC 45, *Rubber and rubber products*, Subcommittee SC 2, *Testing and analysis*.

This fourth edition cancels and replaces the third edition (ISO 6505:2005), which has been technically revised.

Introduction

In assemblies which include both metallic and rubber components, it is essential to avoid unintentional adhesion of rubber to metal, and corrosion of the metal by the rubber. Adhesion occurs only where there is direct contact between the metal and the rubber, but corrosion can also arise, within a closed system, on metal components remote from the rubber, such corrosion being due to volatile materials emanating from the rubber.

Since some metals corrode more readily than others, it is not possible to specify optimum test conditions for assessing the resistance to corrosion of all metals and alloys. Furthermore, the ranking of a metal's susceptibility to corrosion will depend upon the environment in which it is exposed to the rubber, e.g. in the presence of high humidity the effects on steel, in particular, can be severe.

iTeh STANDARD PREVIEW (standards.iteh.ai)

[ISO 6505:2015](https://standards.iteh.ai/catalog/standards/sist/583c4426-9d39-4af3-901c-abcbbf6f57ef/iso-6505-2015)

<https://standards.iteh.ai/catalog/standards/sist/583c4426-9d39-4af3-901c-abcbbf6f57ef/iso-6505-2015>

iTeh STANDARD PREVIEW
(standards.iteh.ai)

ISO 6505:2015

<https://standards.iteh.ai/catalog/standards/sist/583c4426-9d39-4af3-901c-abcbbf6f57ef/iso-6505-2015>

Rubber, vulcanized or thermoplastic — Determination of tendency to adhere to and corrode metals

WARNING 1 — Persons using this International Standard should be familiar with normal laboratory practice. This standard does not purport to address all of the safety problems, if any, associated with its use. It is the responsibility of the user to establish appropriate safety and health practices and to ensure compliance with any national regulatory conditions.

WARNING 2 — Certain procedures specified in this International Standard might involve the use or generation of substances, or the generation of waste, that could constitute a local environmental hazard. Reference should be made to appropriate documentation on safe handling and disposal after use.

1 Scope

This International Standard specifies a method for the determination of the tendency of vulcanized or thermoplastic rubbers to adhere to and to corrode metals when exposed to a specified test environment.

2 Normative references

The following referenced documents are indispensable for the application of this document. For dated references, only the edition cited applies. For undated references, the latest edition of the referenced document (including any amendments) applies.

ISO 48, *Rubber, vulcanized or thermoplastic — Determination of hardness (hardness between 10 IRHD and 100 IRHD)* ISO 6505:2015
<https://standards.iteh.ai/catalog/standards/sist/583c4426-9d39-4af3-901c-abcbbf6f57ef/iso-6505-2015>

ISO 3310-1, *Test sieves — Technical requirements and testing — Part 1: Test sieves of metal wire cloth*

ISO 18899:2004, *Rubber — Guide to the calibration of test equipment*

ISO 23529, *Rubber — General procedures for preparing and conditioning test pieces for physical test methods*

3 Principle

Rubber test pieces are held between metal test strips under specified conditions in a dry or wet atmosphere for a specified period.

Subsequent visual examination of the metal surface provides a subjective indication of the degree of adhesion to the metal by the rubber and corrosion of the metal.

4 Materials

4.1 Acetone, (for cleaning of metal) of recognized analytical quality.

4.2 Other suitable solvents, (for cleaning of rubber) of recognized analytical quality and which do not have any deleterious effects on the rubber under test.

4.3 Pumice powder, passing a test sieve of nominal aperture size 53 μm complying with the requirements of ISO 3310-1.

4.4 Distilled water, or water of equivalent purity.

4.5 Silica gel.

5 Apparatus

5.1 Usual laboratory equipment, plus the following.

5.2 **Support jig**, to align the metal test strips and rubber test pieces, capable of supporting the clamping force, and with a facility for setting clamps to maintain the clamping force on the assembled test piece “sandwich” throughout the test period (see [Figure 1](#)).

5.3 **Test chamber**, complying with the requirements specified in ISO 23529, with facilities for controlling the temperature within the tolerance limits given in ISO 23529.

For tests other than those in a “dry” atmosphere, a suitable means for controlling the humidity to within the tolerance limits given in ISO 23529 shall be provided.

For tests in a “dry” atmosphere (less than 10 % humidity), a desiccator may be used. For tests at elevated temperature, it is common practice to assume low humidity.

For tests in a “wet” atmosphere (approximately 90 % humidity), a desiccator may be used with an open vessel at the bottom containing a mixture of 33 parts by mass of glycerol and 67 parts by mass of water. The relative density of this mixture will be 1,080 6 at 20 °C. The relative humidity above its surface will be approximately 90 % at 23 °C.

iTeh STANDARD PREVIEW
(standards.iteh.ai)

5.4 **Polyethylene gloves**, or other suitable equipment to prevent direct contact with the test surfaces.

5.5 **Magnifying glass**, of magnification $\times 3$ to $\times 5$.

[ISO 6505:2015](#)

5.6 **Weights**, with flat bottoms.

<https://standards.iteh.ai/catalog/standards/sist/583c4426-9d39-4af3-901c-abcbbf6f57ef/iso-6505-2015>

6 Test metals

The test metals used shall be those specified in the relevant material specification. If the metals are not so specified, they shall be cut from commercial flat sheet or bar, preferably complying with a national standard, and agreed between the interested parties.

NOTE The specific grades of metal specified in previous editions of this International Standard are no longer available. Aluminium and mild steel are most commonly used but copper, brass or other metal might be appropriate for particular applications

Dimensions in millimetres

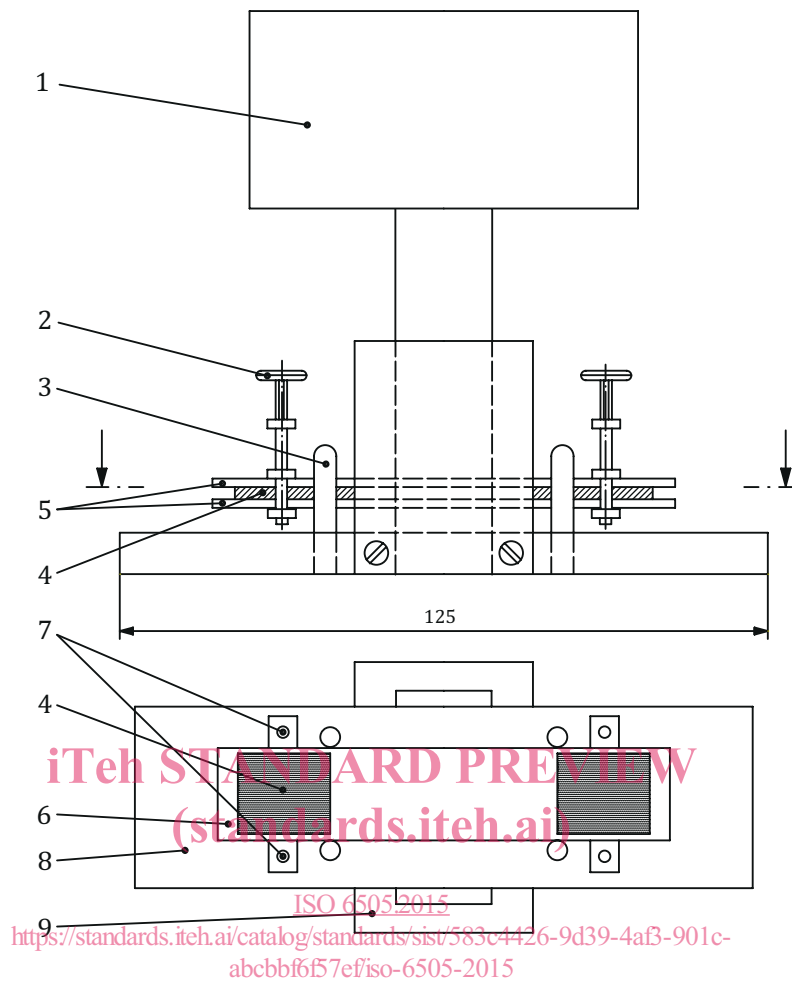

Key

- | | | | | | |
|---|--------------|---|-------------------------|---|-------------------------|
| 1 | 10 kg weight | 4 | rubber test piece | 7 | positions of clamps |
| 2 | screw clamp | 5 | metal test strips | 8 | support base |
| 3 | locating pin | 6 | bottom metal test strip | 9 | guides for 10 kg weight |

Figure 1 — Typical support jig

The metal test strips shall have a thickness sufficient to withstand the clamping force without bending. If only thin foil is available, it shall be supported by a rigid backing material previously shown to be non-corrosive to the test metals.

The test metals shall be in the form of strips with dimensions as given in [Table 1](#):

Table 1 — Dimensions of metal test strips

Width mm	Length (min.) mm	Comments
25 ± 1	100	For use with square test pieces measuring 20 mm × 20 mm
50 ± 1	100	For use with O-rings with an outer diameter of 18 mm to 45 mm

7 Calibration

The requirements for calibration of the test apparatus are given in [Annex A](#)

8 Test pieces

8.1 Preparation

8.1.1 Square test pieces

Square test pieces shall be $(20 \pm 0,5)$ mm × $(20 \pm 0,5)$ mm and preferably with a thickness of $(2,0 \pm 0,2)$ mm. They shall be cut or punched from sheet or from the product under evaluation in accordance with ISO 23529.

8.1.2 O-ring test pieces

O-ring test pieces shall have a cross-sectional diameter of $(3,55 \pm 0,1)$ mm. The outer diameter of the test piece shall be min. 18 mm and max. 45 mm.

8.2 Number

At least two test pieces shall be used for each test.

8.3 Time-interval between forming the material and testing

The time-interval between forming the material and testing shall be in accordance with ISO 23529.

8.4 Storage

Samples and test pieces shall be protected from light as completely as possible during the interval between forming and testing.

9 Test conditions

9.1 Temperature

The test temperature shall be selected from the list in ISO 23529.

9.2 Test period

The duration of the test shall be selected from the following: 24_{-2}^0 h; 72_{-2}^0 h; (96 ± 2) h; (120 ± 2) h; (168 ± 2) h and multiples of 7 days.

NOTE The test period of 120 h has been included alongside periods from ISO 23529 because it is used in material specifications, especially for testing in a wet atmosphere.

9.3 Humidity

In terms of humidity, the atmosphere shall be

- a) either a dry atmosphere having a relative humidity of less than 10 %, or
- b) a wet atmosphere having a relative humidity of (90 ± 5) %.

NOTE This test is commonly carried out at low humidity to ensure that corrosion resulting from causes other than those due to the rubber is minimized.

10 Procedure

10.1 Precaution

In all operations, it is essential that the rubber test pieces and the metal test strips are handled only by means of the polyethylene gloves or other protective equipment (see 5.4). This precaution is essential in order to minimize surface contamination of the test piece and metal strips.

10.2 Preparation of rubber test pieces for testing

Clean all the surfaces of the rubber test pieces with cotton wool pads moistened with a suitable solvent (see 4.2) to remove surface contamination (by mould release agents, for example). The solvent to be used will depend on the rubber under test; it shall not have any deleterious effects on the rubber (e.g. acetone should not be used for nitrile rubber; isopropyl alcohol is preferred for this material).

Allow the test pieces to dry in air. When dry, store the test pieces, unless otherwise specified, in a clean desiccator over silica gel at standard laboratory temperature (see ISO 23529) for at least 24 h immediately prior to testing.

Since cleaning of the test pieces might also remove from the rubber surface materials such as waxes, antiozonants, etc., which would normally be expected to affect the adhesion and corrosion properties of the rubber, allow sufficient time in the desiccator for the re-formation of the "original" surface before testing.

10.3 Number of metal test strips

For each test, use two suitable metal test strips as specified in the material specification or selected from the metals specified in [Clause 6](#).

For tests in a wet atmosphere, use only one type of metal in the construction of the test piece "sandwich" in order to avoid electrolytic effects.

10.4 Preparation of surfaces of metal test strips

Thoroughly scour the test surfaces of the metal test strips using a slurry of pumice powder (4.3) in water applied with a cotton wool pad until a matt surface is obtained. Thoroughly rinse the metal strips with water (4.4) and then with acetone (4.1) and finally dry in air. If the prepared metal test strips are not to be used immediately after cleaning, store them in a clean desiccator over silica gel for not more than 24 h before testing.