**Rubber, vulcanized or
thermoplastic — Determination of
tear strength —**

**Part 1:
Trouser, angle and crescent test pieces**

iTeh STANDARD PREVIEW
*Caoutchouc vulcanisé ou thermoplastique — Détermination de la
résistance au déchirement —
(standards.iteh.ai)
Partie 1: Éprouvettes pantalon, angulaire et croissant*

[ISO 34-1:2015](https://standards.iteh.ai/catalog/standards/sist/a2b8314d-13fd-46cb-aad6-44293c0246a2/iso-34-1-2015)

<https://standards.iteh.ai/catalog/standards/sist/a2b8314d-13fd-46cb-aad6-44293c0246a2/iso-34-1-2015>



iTeh STANDARD PREVIEW
(standards.iteh.ai)

ISO 34-1:2015

<https://standards.iteh.ai/catalog/standards/sist/a2b8314d-13fd-46cb-aad6-44293c0246a2/iso-34-1-2015>



COPYRIGHT PROTECTED DOCUMENT

© ISO 2015, Published in Switzerland

All rights reserved. Unless otherwise specified, no part of this publication may be reproduced or utilized otherwise in any form or by any means, electronic or mechanical, including photocopying, or posting on the internet or an intranet, without prior written permission. Permission can be requested from either ISO at the address below or ISO's member body in the country of the requester.

ISO copyright office
Ch. de Blandonnet 8 • CP 401
CH-1214 Vernier, Geneva, Switzerland
Tel. +41 22 749 01 11
Fax +41 22 749 09 47
copyright@iso.org
www.iso.org

Contents

	Page
Foreword	iv
1 Scope	1
2 Normative references	2
3 Terms and definitions	2
4 Principle	2
5 Apparatus	3
6 Calibration	5
7 Test piece	6
8 Number of test pieces	6
9 Temperature of test	6
10 Procedure	7
11 Expression of results	7
12 Test report	7
Annex A (informative) Precision results from an interlaboratory test programme	9
Annex B (normative) Calibration schedule	13
Bibliography	15

iTech STANDARD PREVIEW
(standards.itech.ai)

[ISO 34-1:2015](https://standards.itech.ai/catalog/standards/sist/a2b8314d-13fd-46cb-aad6-44293c0246a2/iso-34-1-2015)

<https://standards.itech.ai/catalog/standards/sist/a2b8314d-13fd-46cb-aad6-44293c0246a2/iso-34-1-2015>

Foreword

ISO (the International Organization for Standardization) is a worldwide federation of national standards bodies (ISO member bodies). The work of preparing International Standards is normally carried out through ISO technical committees. Each member body interested in a subject for which a technical committee has been established has the right to be represented on that committee. International organizations, governmental and non-governmental, in liaison with ISO, also take part in the work. ISO collaborates closely with the International Electrotechnical Commission (IEC) on all matters of electrotechnical standardization.

The procedures used to develop this document and those intended for its further maintenance are described in the ISO/IEC Directives, Part 1. In particular the different approval criteria needed for the different types of ISO documents should be noted. This document was drafted in accordance with the editorial rules of the ISO/IEC Directives, Part 2 (see www.iso.org/directives).

Attention is drawn to the possibility that some of the elements of this document may be the subject of patent rights. ISO shall not be held responsible for identifying any or all such patent rights. Details of any patent rights identified during the development of the document will be in the Introduction and/or on the ISO list of patent declarations received (see www.iso.org/patents).

Any trade name used in this document is information given for the convenience of users and does not constitute an endorsement.

For an explanation on the meaning of ISO specific terms and expressions related to conformity assessment, as well as information about ISO's adherence to the WTO principles in the Technical Barriers to Trade (TBT) see the following URL: [Foreword - Supplementary information](#)

The committee responsible for this document is ISO/TC45, *Rubber and rubber products*, Subcommittee SC 2, *Testing and analysis*.

This fourth edition cancels and replaces the third edition (ISO 34-1:2010), which has been technically revised. Precision results from an interlaboratory have been updated as [Annex A](#).

ISO 34 consists of the following parts, under the general title *Rubber, vulcanized or thermoplastic — Determination of tear strength*:

- *Part 1: Trouser, angle and crescent test pieces*
- *Part 2: Small (Delft) test pieces*

Rubber, vulcanized or thermoplastic — Determination of tear strength —

Part 1: Trouser, angle and crescent test pieces

WARNING 1 — Persons using this part of ISO 34 should be familiar with normal laboratory practice. This part of ISO 34 does not purport to address all of the safety problems, if any, associated with its use. It is the responsibility of the user to establish appropriate safety and health practices and to ensure compliance with any national regulatory conditions.

WARNING 2 — Certain procedures specified in this part of ISO 34 might involve the use or generation of substances, or the generation of waste, that could constitute a local environmental hazard. Reference should be made to appropriate documentation on safe handling and disposal after use.

1 Scope

This part of ISO 34 specifies three test methods for the determination of the tear strength of vulcanized or thermoplastic rubber, namely the following:

- method A, using a trouser test piece;
- method B, using an angle test piece, with or without a nick of specified depth;
- method C, using a crescent test piece with a nick.

The value of tear strength obtained depends on the shape of the test piece, speed of stretching, and temperature of test. It can also be susceptible to grain effects in rubber.

Method A: Using a trouser test piece

Method A, using the trouser test piece, is preferred because it is not sensitive to the length of the cut, unlike the other two test pieces in which the nick has to be very closely controlled. In addition, the results obtained are more easily related to the fundamental tear properties of the material and are less sensitive to modulus effects (provided that the leg extension is negligible) and the rate of propagation of the tear is directly related to the rate of grip separation. With some rubbers, the propagation of tear is not smooth (knotty tear), and analysis of results can be difficult.^[3]

Method B, procedure (a): Using an angle test piece without nick

This test is a combination of tear initiation and propagation. Stress is built up at the point of the angle until it is sufficient to initiate a tear and then further stresses propagate this tear. However, it is only possible to measure the overall force required to rupture the test piece, and, therefore, the force cannot be resolved in two components producing initiation and propagation.^[4]

Method B, procedure (b): Using an angle test piece with nick

This test measures the force required to propagate a nick already produced in the test piece. The rate of propagation is not directly related to the jaw speed.^[5]

Method C: Using a crescent test piece

This test also measures the force required to propagate a nick already produced in the test piece, and the rate of propagation is not related to the jaw speed.

NOTE A separate method for the determination of the tear strength of small test pieces of rubber (Delft test pieces) is specified in ISO 34-2.^[1]

2 Normative references

The following documents, in whole or in part, are normatively referenced in this document and are indispensable for its application. For dated references, only the edition cited applies. For undated references, the latest edition of the referenced document (including any amendments) applies.

ISO 5893, *Rubber and plastics test equipment — Tensile, flexural and compression types (constant rate of traverse) — Specification*

ISO 6133, *Rubber and plastics — Analysis of multi-peak traces obtained in determinations of tear strength and adhesion strength*

ISO 18899:2013, *Rubber — Guide to the calibration of test equipment*

ISO 23529, *Rubber — General procedures for preparing and conditioning test pieces for physical test methods*

3 Terms and definitions

For the purposes of this document, the following terms and definitions apply.

3.1 trouser tear strength

median force required to propagate a cut in a specified trouser-shaped test piece by tearing, divided by the thickness of the test piece, the force acting in a direction substantially in the plane of the cut

Note 1 to entry: The median force is calculated in accordance with ISO 6133.

3.2 unnicked angle tear strength

maximum force required to rupture a specified angle-shaped test piece, divided by the thickness of the test piece, the force acting in a direction substantially along the length of the test piece

3.3 nicked angle tear strength crescent tear strength

maximum force required to cause a nick cut in a specified angle- or crescent-shaped test piece to extend by tearing of the rubber, divided by the thickness of the test piece, the force acting in a direction substantially normal to the plane of the nick

4 Principle

The test consists in measuring the force required to tear a specified test piece, in continuation of the cut or nick already produced in the test piece or, in the case of method B, procedure (a), completely across the width of the test piece.

The tearing force is applied by means of a tensile testing machine, operated without interruption at a constant rate of traverse until the test piece breaks. Dependent upon the method employed, the maximum or median force achieved is used to calculate the tear strength.

No correlation between data obtained by the alternative test pieces is implied.

5 Apparatus

5.1 Dies

5.1.1 The die used for cutting trouser test pieces shall have the dimensions shown in [Figure 1](#).

5.1.2 The die used for cutting angle test pieces shall have the dimensions shown in [Figure 2](#).

5.1.3 The die used for cutting crescent test pieces shall have the dimensions shown in [Figure 3](#).

5.1.4 The cutting edges of the dies shall be kept sharp and free from ragged edges. Care shall be taken that the cutting edges are perpendicular to the other surfaces of the die and have a minimum of concavity.

5.2 Nick cutter

A sharp razor blade or a sharp knife free from ragged edges shall be used for producing a cut or a nick in the test piece.

The apparatus for introducing the nick required for the nicked angle or crescent test piece shall be as follows.

Means shall be provided for clamping the test piece firmly, especially in the region where the nick is to be introduced. The cutting tool, consisting of a razor blade or similar blade, shall be clamped in a plane perpendicular to the major axis of the test piece, and positioned so as to introduce the nick in the appropriate place. The blade clamping device shall permit no lateral movement and shall be fitted in guides to enable the blade to be moved across the test piece with its edge remaining perpendicular to the plane of the test piece. Alternatively, the blade shall be fixed and the test piece arranged to move in an analogous manner. Means shall be provided for fine adjustment of the depth of the nick. The adjustment of the position of the blade holder or clamped test piece shall be determined for each blade by cutting one or two preliminary nicks and measuring these with the aid of a microscope. The blade shall be wetted with water or soap solution prior to nicking.

NOTE A suitable apparatus for nicking tear test pieces has been described in detail in the literature.^[6]

To check that the depth of the nick is within the specified limits (see [7.4](#)), any suitable means may be used, e.g. an optical projection apparatus. A convenient arrangement is a microscope giving at least 10× magnification fitted with a travelling stage suitably illuminated. The eyepiece is fitted with a graticule or crosswire by which to record the travel of the stage and test piece through a distance equal to the depth of the nick. The travel of the stage is calibrated with a stage micrometer.

Alternatively, a travelling microscope may be used.

The apparatus shall have an accuracy of measurement of 0,05 mm.

5.3 Testing machine

The machine shall conform to the requirements of ISO 5893, to an accuracy corresponding to class 1.

It shall be capable of registering the applied forces within 1 % during the test while maintaining the specified constant rate of separation of the jaws of 100 mm/min ± 10 mm/min for the trouser test piece and 500 mm/min ± 50 mm/min for the angle and crescent test pieces. A low-inertia machine having autographic force-recording facilities is essential when using the trouser test piece.

5.4 Grips

The machine shall be provided with a type of grip which tightens automatically as the tension increases and exerts a uniform pressure across the widened end of the test piece. Each grip shall incorporate a means for positioning so that the test pieces are inserted symmetrically and in axial alignment with the direction of the pull. The depth of insertion shall be such that the test piece is adequately gripped,

within the parallel-sides portion, when testing angle and crescent test pieces. Trouser test pieces shall be inserted in the grips in accordance with [Figure 4](#).

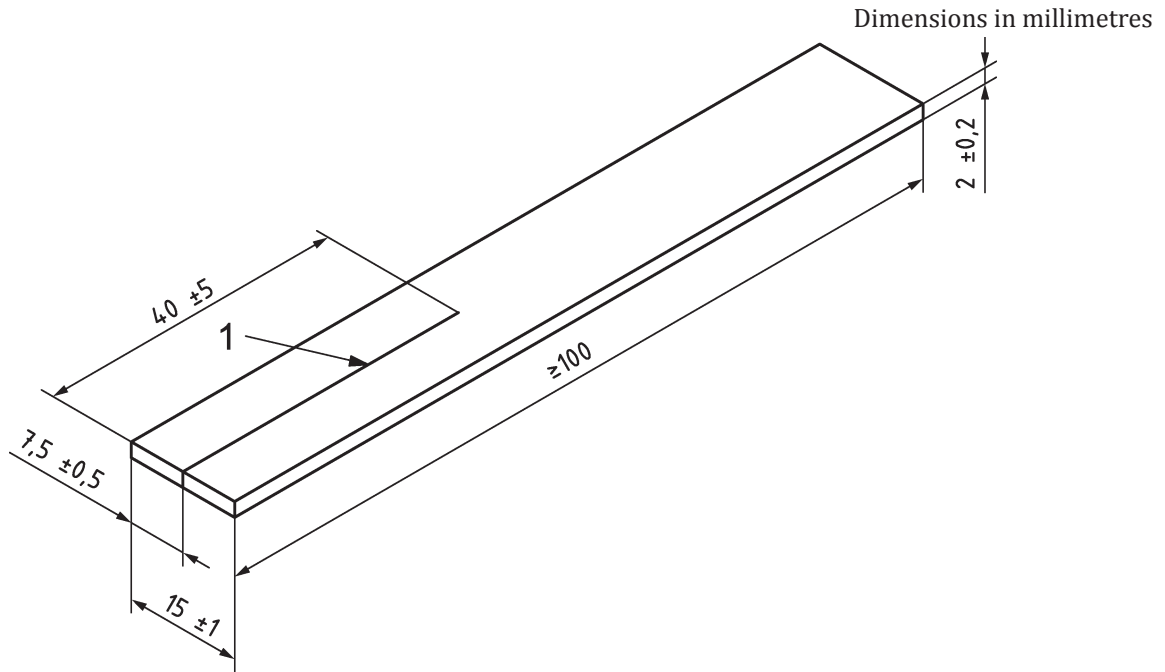

Key
1 location of cut

iTeh STANDARD PREVIEW
(standards.iteh.ai)

Figure 1 — Trouser test piece die

<https://standards.iteh.ai/catalog/standards/sist/a2b8314d-13fd-46cb-aad6-44293c0246a2/iso-34-1-2015>

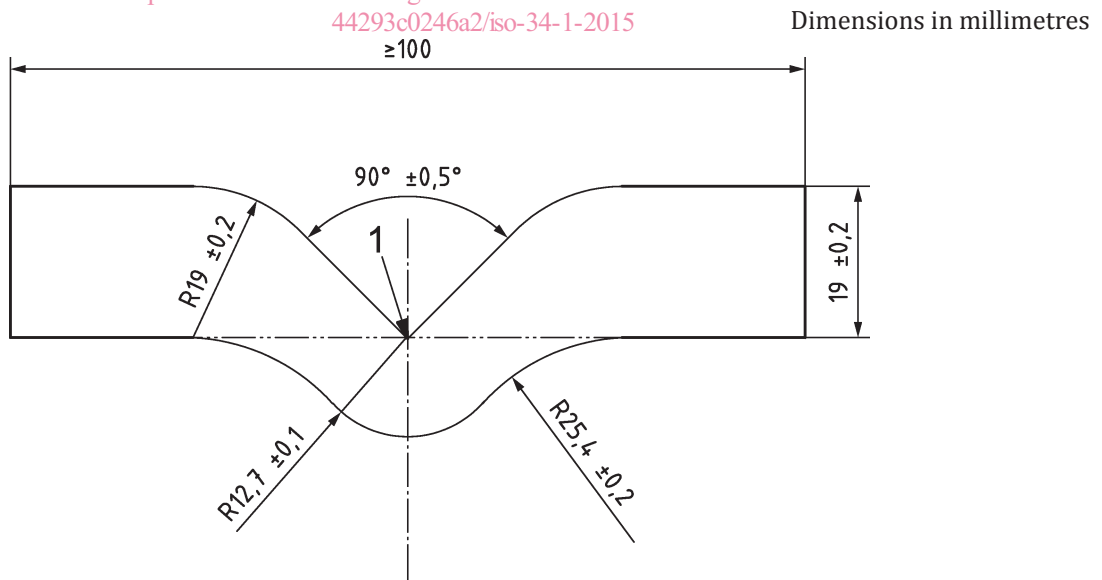

Key
1 location of nick for method B, procedure (b)

Figure 2 — Angle test piece die

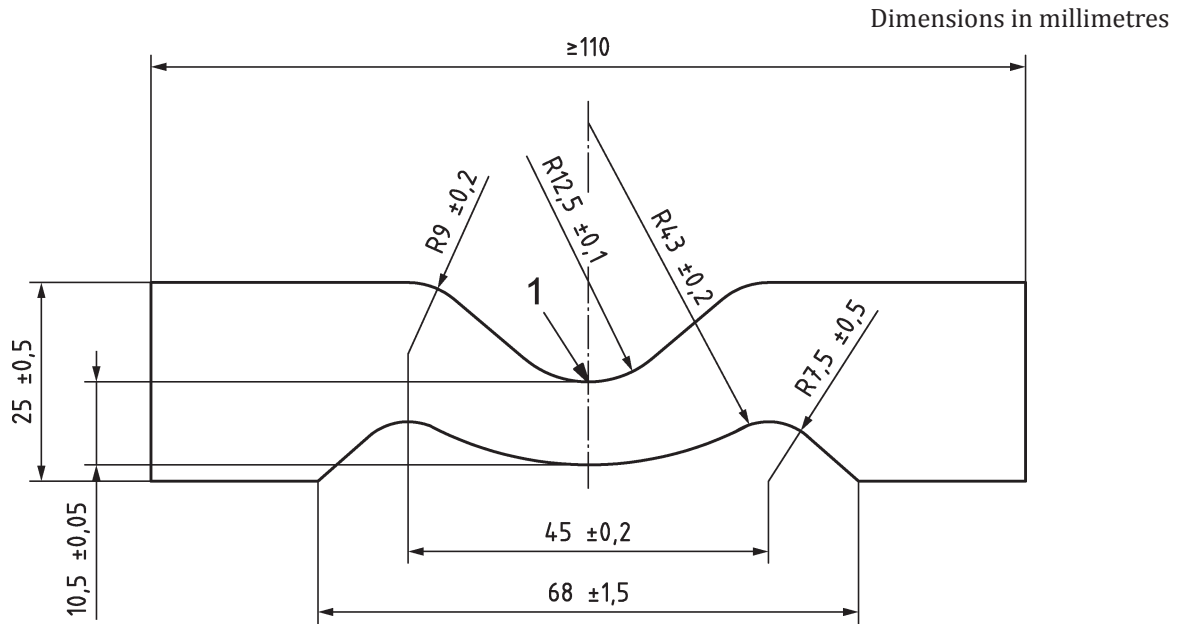

Key

- 1 location of nick

Figure 3 — Crescent test piece die
 iTeh STANDARD PREVIEW
 (standards.iteh.ai)

ISO 34-1:2015
<https://standards.iteh.ai/catalog/standards/sist/a2b8314d-13fd-46cb-aad6-44293c0246a2/iso-34-1-2015>

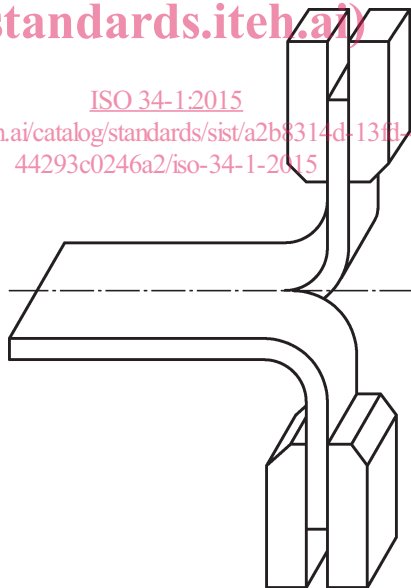

Figure 4 — Positioning of trouser test piece in testing machine

6 Calibration

The test apparatus shall be calibrated in accordance with the schedule given in [Annex B](#).

7 Test piece

7.1 Test pieces shall be cut from rubber sheet of uniform thickness. Preferably, the sheet shall have a thickness of $2,0 \text{ mm} \pm 0,2 \text{ mm}$; however, it is recognized that, when sheets are prepared from finished products, this thickness cannot always be achieved.

Sheets may be moulded or prepared from products by cutting or buffing.

The requirements of ISO 23529 shall apply to the time interval between forming or preparation of the sheet and cutting of test pieces. During this interval, the sheets shall be protected from light as completely as possible.

7.2 The sheets shall be conditioned at standard laboratory temperature (see ISO 23529) for at least 3 h before test pieces are cut from them.

Each test piece shall be cut from the sheet by punching with a die, shaped as shown in [Figure 1](#), [Figure 2](#) or [Figure 3](#), using a single stroke of the press. The rubber shall be wetted with water or soap solution and shall be supported on a sheet of slightly yielding material (e.g. leather, rubber belting or cardboard) on a flat rigid surface.

7.3 Each test piece shall, if possible, be taken in such a way that the tear strength can be determined in two directions which are at an angle of 90° to one another. The directions in which the test piece is taken shall be indicated so that the effect of anisotropy can be assessed.

The direction of tear propagation is parallel to the length of the trouser test piece and perpendicular to the length of the angle and crescent test pieces.

7.4 Test pieces shall be cut or nicked to a depth as given in this subclause by the apparatus specified in [5.2](#).

Method A (trouser test piece) — Cut of depth $40 \text{ mm} \pm 5 \text{ mm}$ made at the centre of the width of the test piece (see [Figure 1](#)). It is important that the last 1 mm (approximately) of the cut is made with a razor blade or a sharp knife.

Method B, procedure (b) (angle test piece) — Nick of depth $1,0 \text{ mm} \pm 0,2 \text{ mm}$ at the apex of the internal angle of the test piece (see [Figure 2](#)).

Method C (crescent test piece) — Nick of depth $1,0 \text{ mm} \pm 0,2 \text{ mm}$ at the centre of the concave inner edge of the test piece (see [Figure 3](#)).

Test pieces shall be nicked or cut, measured and then tested, preferably immediately, but if not tested immediately they shall be kept at chosen standard laboratory temperature until tested. The period between nicking or cutting of the test piece and testing shall not exceed 24 h. The cut or nick shall be made after any ageing treatment has been carried out.

8 Number of test pieces

At least five test pieces per sample shall be tested and, where possible, five from each of the directions referred to in [7.3](#).

9 Temperature of test

The test is normally carried out at a standard laboratory temperature, as specified in ISO 23529. When other temperatures are required, these shall be selected from ISO 23529.

If the test is to be carried out at a temperature other than a standard laboratory temperature, the test piece shall be conditioned for a period sufficient to reach substantial temperature equilibrium at the test temperature, immediately prior to testing. This period shall be kept as short as possible in order to avoid ageing the rubber (see ISO 23529).

The same temperature shall be used throughout any one test or series of tests intended to be comparable.

10 Procedure

Measure the thickness of the test piece in the region in which tearing is expected to occur and in accordance with ISO 23529. No measurement on any one test piece shall deviate by more than 2 % from the median value of the thickness of that test piece. If groups of test pieces are being compared, the median thickness of each group shall be within 7,5 % of the grand median thickness of all the groups.

After conditioning as described in [Clause 9](#), immediately mount the test piece in the testing machine ([5.3](#)) as described in [5.4](#). Extend the test piece at a rate of separation of the grips of 500 mm/min \pm 50 mm/min for angle and crescent type test pieces and 100 mm/min \pm 10 mm/min for trouser test pieces until the test piece breaks. Record the maximum force for crescent and angle test pieces. When using trouser test pieces, make an autographic recording of the force throughout the tearing process.

11 Expression of results

The tear strength T_s , expressed in kilonewtons per metre of thickness, is given in Formula (1):

$$T_s = \frac{F}{d} \quad (1)$$

where

F is the maximum force, in newtons, when using method B or C, and the median force, in newtons, calculated in accordance with ISO 6133, when using method A;

d is the median thickness, in millimetres, of the test piece.

Determine the median and the range of the values for each direction of testing.

Express the results to the nearest kilonewton per metre.

12 Test report

The test report shall include at least the following information:

- a) sample details:
 - 1) full description of the sample and its origin,
 - 2) method of preparation of test piece from the sample, e.g. moulded or cut;
- b) test method:
 - 1) full reference to the test method used (ISO 34-1:2015),
 - 2) test procedure used,
 - 3) type of test piece used;
- c) test details:
 - 1) standard laboratory temperature,
 - 2) time and temperature of conditioning prior to test,
 - 3) temperature of test, if other than standard laboratory temperature, and the relative humidity, if necessary,