



SLOVENSKI STANDARD
SIST ISO 16656:2021

01-julij-2021

Nadomešča:
SIST ISO 16656:2005

Fluidna tehnika - Hidravlika - Kratkohodni valji z enostransko batnico s premeri 32 mm do 100 mm in za 10 MPa (100 bar) - Vgradne mere

Hydraulic fluid power -- Single rod, short-stroke cylinders with bores from 32 mm to 100 mm for use at 10 MPa (100 bar) -- Mounting dimensions

iTeh STANDARD PREVIEW
(standards.iteh.ai)

Transmissions hydrauliques -- Vérins course courte à simple tige, d'alésages 32 mm à 100 mm, pour utilisation à 10 MPa (100 bar) -- Dimensions d'interchangeabilité

<https://standards.iteh.ai/catalog/standards/sist/ca7a435a-c730-459c-963f-77e836a7ab7e/sist-iso-16656-2021>

Ta slovenski standard je istoveten z: ISO 16656:2016

ICS:

23.100.20 Hidravlični valji Cylinders

SIST ISO 16656:2021 **en**

iTeh STANDARD PREVIEW
(standards.iteh.ai)

SIST ISO 16656:2021

<https://standards.iteh.ai/catalog/standards/sist/ca7a435a-c730-459c-963f-77e836a7ab7e/sist-iso-16656-2021>

INTERNATIONAL
STANDARDISO
16656Second edition
2016-08-01

**Hydraulic fluid power — Single rod,
short-stroke cylinders with bores
from 32 mm to 100 mm for use
at 10 MPa (100 bar) — Mounting
dimensions**

*Transmissions hydrauliques — Vérins course courte à simple tige,
d'alésages 32 mm à 100 mm, pour utilisation à 10 MPa (100 bar) —
Dimensions d'interchangeabilité*

iTeh STANDARD PREVIEW
(standards.iteh.ai)

[SIST ISO 16656:2021](https://standards.iteh.ai/catalog/standards/sist/ca7a435a-c730-459c-963f-77e836a7ab7e/sist-iso-16656-2021)

<https://standards.iteh.ai/catalog/standards/sist/ca7a435a-c730-459c-963f-77e836a7ab7e/sist-iso-16656-2021>



Reference number
ISO 16656:2016(E)

© ISO 2016

iTeh STANDARD PREVIEW (standards.iteh.ai)

SIST ISO 16656:2021

<https://standards.iteh.ai/catalog/standards/sist/ca7a435a-c730-459c-963f-77e836a7ab7e/sist-iso-16656-2021>



COPYRIGHT PROTECTED DOCUMENT

© ISO 2016, Published in Switzerland

All rights reserved. Unless otherwise specified, no part of this publication may be reproduced or utilized otherwise in any form or by any means, electronic or mechanical, including photocopying, or posting on the internet or an intranet, without prior written permission. Permission can be requested from either ISO at the address below or ISO's member body in the country of the requester.

ISO copyright office
Ch. de Blandonnet 8 • CP 401
CH-1214 Vernier, Geneva, Switzerland
Tel. +41 22 749 01 11
Fax +41 22 749 09 47
copyright@iso.org
www.iso.org

Contents

	Page
Foreword	iv
Introduction	v
1 Scope	1
2 Normative references	1
3 Terms and definitions	1
4 Bore sizes	2
5 Nominal strokes	2
6 Piston rod characteristics	2
7 Dimensions	2
8 Identification statement (reference to this International Standard)	5

iTeh STANDARD PREVIEW (standards.iteh.ai)

[SIST ISO 16656:2021](https://standards.iteh.ai/catalog/standards/sist/ca7a435a-c730-459c-963f-77e836a7ab7e/sist-iso-16656-2021)

<https://standards.iteh.ai/catalog/standards/sist/ca7a435a-c730-459c-963f-77e836a7ab7e/sist-iso-16656-2021>

ISO 16656:2016(E)

Foreword

ISO (the International Organization for Standardization) is a worldwide federation of national standards bodies (ISO member bodies). The work of preparing International Standards is normally carried out through ISO technical committees. Each member body interested in a subject for which a technical committee has been established has the right to be represented on that committee. International organizations, governmental and non-governmental, in liaison with ISO, also take part in the work. ISO collaborates closely with the International Electrotechnical Commission (IEC) on all matters of electrotechnical standardization.

The procedures used to develop this document and those intended for its further maintenance are described in the ISO/IEC Directives, Part 1. In particular the different approval criteria needed for the different types of ISO documents should be noted. This document was drafted in accordance with the editorial rules of the ISO/IEC Directives, Part 2 (see www.iso.org/directives).

Attention is drawn to the possibility that some of the elements of this document may be the subject of patent rights. ISO shall not be held responsible for identifying any or all such patent rights. Details of any patent rights identified during the development of the document will be in the Introduction and/or on the ISO list of patent declarations received (see www.iso.org/patents).

Any trade name used in this document is information given for the convenience of users and does not constitute an endorsement.

For an explanation on the meaning of ISO specific terms and expressions related to conformity assessment, as well as information about ISO's adherence to the WTO principles in the Technical Barriers to Trade (TBT) see the following URL: [Foreword - Supplementary information](http://standards.iteh.ai)

The committee responsible for this document is ISO/TC 131, *Fluid power systems*, Subcommittee SC 3, *Cylinders*.

SIST ISO 16656:2021

This second edition cancels and replaces the first edition (ISO 16656:2004), of which it constitutes a minor revision.

standards.iteh.ai
77e836a7ab7e/sist-iso-16656-2021

Introduction

In hydraulic fluid power systems, power is transmitted and controlled through a liquid under pressure within an enclosed circuit.

One component of such systems is the fluid power cylinder. This is a device that converts power into linear mechanical force and motion. It consists of a movable element, i.e. a piston and piston rod, operating within a cylindrical bore.

iTeh STANDARD PREVIEW (standards.iteh.ai)

[SIST ISO 16656:2021](https://standards.iteh.ai/catalog/standards/sist/ca7a435a-c730-459c-963f-77e836a7ab7e/sist-iso-16656-2021)

<https://standards.iteh.ai/catalog/standards/sist/ca7a435a-c730-459c-963f-77e836a7ab7e/sist-iso-16656-2021>

iTeh STANDARD PREVIEW
(standards.iteh.ai)

SIST ISO 16656:2021

<https://standards.iteh.ai/catalog/standards/sist/ca7a435a-c730-459c-963f-77e836a7ab7e/sist-iso-16656-2021>

Hydraulic fluid power — Single rod, short-stroke cylinders with bores from 32 mm to 100 mm for use at 10 MPa (100 bar) — Mounting dimensions

1 Scope

This International Standard establishes mounting dimensions for single rod short-stroke cylinders with bores from 32 mm to 100 mm for use at 10 MPa (100 bar) with or without magnetic functions, as required for interchangeability of these commonly used hydraulic cylinders.

NOTE 1 This International Standard is intended to provide basic guidelines while allowing manufacturers of hydraulic equipment flexibility in the design of cylinders and not restricting technical development.

NOTE 2 The dimensions of these cylinders are most likely to require a minimum of space for mounting.

NOTE 3 1 bar = 0,1 MPa = 10⁵ Pa; 1 MPa = 1 N/mm².

2 Normative references

The following documents, in whole or in part, are normatively referenced in this document and are indispensable for its application. For dated references, only the edition cited applies. For undated references, the latest edition of the referenced document (including any amendments) applies.

ISO 273, *Fasteners — Clearance holes for bolts and screws*

ISO 965-3, *ISO general purpose metric screw threads — Tolerances — Part 3: Deviations for constructional screw threads*

ISO 1179-1, *Connections for general use and fluid power — Ports and stud ends with ISO 228-1 threads with elastomeric or metal-to-metal sealing — Part 1: Threaded ports*

ISO 3320, *Fluid power systems and components — Cylinder bores and piston rod diameters and area ratios — Metric series*

ISO 4393, *Fluid power systems and components — Cylinders — Basic series of piston strokes*

ISO 4395, *Fluid power systems and components — Cylinder piston rod end types and dimensions*

ISO 5598, *Fluid power systems and components — Vocabulary*

ISO 6099, *Fluid power systems and components — Cylinders — Identification code for mounting dimensions and mounting types*

ISO 6149-1, *Connections for hydraulic fluid power and general use — Ports and stud ends with ISO 261 metric threads and O-ring sealing — Part 1: Ports with truncated housing for O-ring seal*

3 Terms and definitions

For the purposes of this document, the terms and definitions given in ISO 5598 and the following apply.

3.1

mounting

method by which a component, piping or system is fastened

Note 1 to entry: Definition which will be included in the next revision of ISO 5598.

ISO 16656:2016(E)

4 Bore sizes

This International Standard provides for the following bore sizes, in millimetres, in accordance with ISO 3320:

32 – 40 – 50 – 63 – 80 – 100

5 Nominal strokes

Nominal strokes in accordance with ISO 4393 shall be selected from those given in [Table 1](#).

Table 1 — Nominal strokes and tolerance

Dimensions in millimetres

Nominal strokes	Tolerance
5, 10, 16, 20, 25, 32, 40, 50	+1 0

6 Piston rod characteristics

This International Standard covers piston rods that have a shouldered male thread end and female thread end (see [Figures 1](#) and [2](#)).

iTeh STANDARD PREVIEW
(standards.iteh.ai)

7 Dimensions

Mounting dimensions for cylinders manufactured in accordance with this International Standard shall be selected from [Figures 1](#) and [2](#) and [Table 2](#).

[SIST ISO 16656:2021](https://standards.iteh.ai/catalog/standards/sist/ca7a435a-c730-459c-963f-77e836a7ab7e/sist-iso-16656-2021)

Identification codes for mounting dimensions and mounting types are in accordance with ISO 6099.

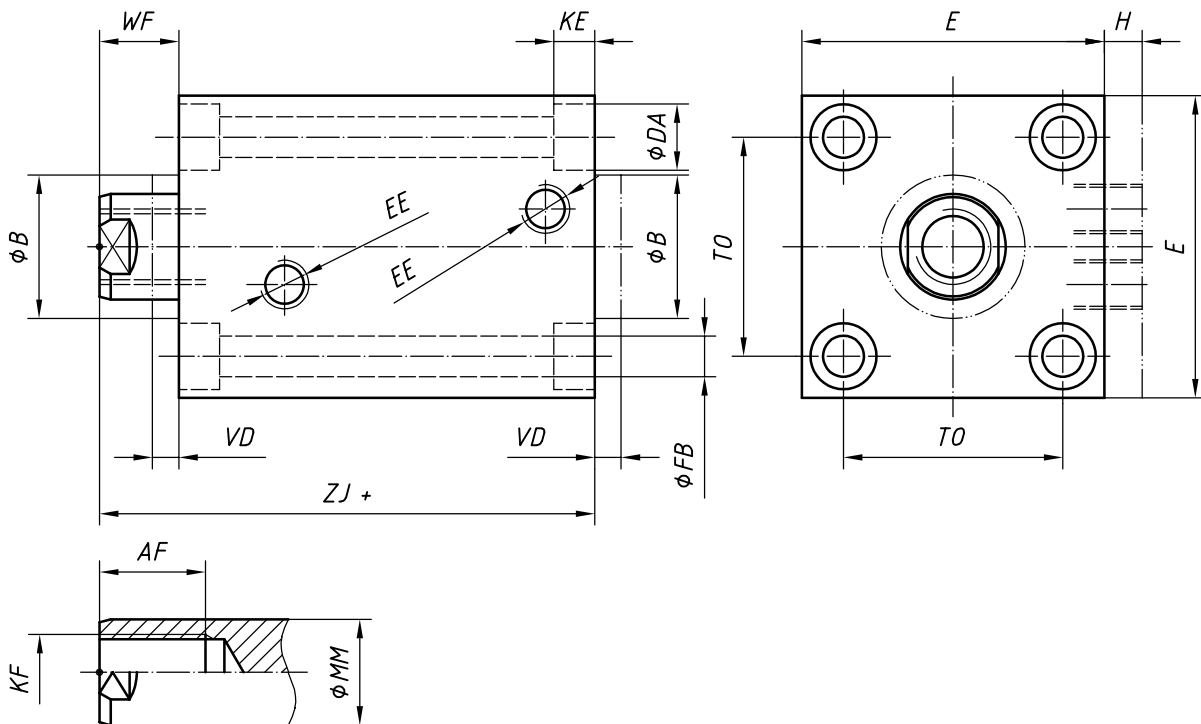

NOTE Pilot extension is optional. The dimensions B and VD should be used if pilot extensions are needed.

Figure 1 — Body, through bolt hole mounting (MB1) — Female threaded rod