



**Designation: E604–83(Reapproved 2002) Designation: E 604 – 83 (Reapproved 2008)**

## Standard Test Method for Dynamic Tear Testing of Metallic Materials<sup>1</sup>

This standard is issued under the fixed designation E 604; the number immediately following the designation indicates the year of original adoption or, in the case of revision, the year of last revision. A number in parentheses indicates the year of last reapproval. A superscript epsilon ( $\epsilon$ ) indicates an editorial change since the last revision or reapproval.

*This standard has been approved for use by agencies of the Department of Defense.*

### 1. Scope

1.1 This test method covers the dynamic tear (DT) test using specimens that are  $\frac{3}{16}$  in. to  $\frac{5}{8}$  in. (5 mm to 16 mm) inclusive in thickness.

1.2 This test method is applicable to materials with a minimum thickness of  $\frac{3}{16}$  in. (5 mm).

1.3 The pressed-knife procedure described for sharpening the notch tip generally limits this test method to materials with a hardness level less than 36 HRC.

NOTE 1—The designation 36 HRC is a Rockwell hardness number of 36 on Rockwell C scale as defined in Test Methods E 18.

1.4 The values stated in inch-pound units are to be regarded as standard. The values given in parentheses are mathematical conversions to SI units that are provided for information only and are not considered standard.

1.5 This standard does not purport to address all of the safety concerns, if any, associated with its use. It is the responsibility of the user of this standard to establish appropriate safety and health practices and determine the applicability of regulatory limitations prior to use.

### 2. Referenced Documents

2.1 *ASTM Standards:*<sup>2</sup>

B 221 Specification for Aluminum-Alloy Extruded Bars, Rods, Wire, Profiles, and Tubes

E 18 Test Methods for Rockwell Hardness and Rockwell Superficial Hardness of Metallic Materials

E 399 Test Method for Linear-Elastic Plane-Strain Fracture Toughness  $K_{Ic}$  of Metallic Materials

### 3. Terminology

3.1 *Description of Terms Specific to this Standard*

3.2 *Dynamic Tear (DT) Energy*—the total energy required to fracture DT specimens tested in accordance with the provisions of this test method.

NOTE 2—With pendulum-type machines, the DT energy is the difference between the initial and the final potential energies of the pendulum or pendulums.

NOTE 3—With drop-weight machines, the DT energy is the difference between the initial potential energy of the hammer and the final energy of the hammer as determined by a calibrated energy measurement system.

3.3 *Percent Shear Fracture Appearance*—Percent shear fracture appearance is the percent of the net section that fractured in a shear mode. Net section can be either the net section area before fracture or the area of the projected plane of the fracture surface.

### 4. Summary of Test Method

4.1 The DT test involves a single-edge notched beam that is impact loaded in three-point bending, and the total energy loss during separation is recorded.

4.2 The DT specimens are fractured with pendulum or drop-weight machines.

<sup>1</sup> This test method is under the jurisdiction of ASTM Committee E28 on Fracture/Mechanical Testing and is the direct responsibility of Subcommittee E28.07 on Impact Testing.

Current edition approved ~~March 25, 1983~~ Sept. 1, 2008. Published ~~July 1983~~ January 2009. Originally published as a proposed test method in November 1975. Last previous edition approved in 2002 as E 604 –83(2002).

<sup>2</sup> Annual Book of ASTM Standards, Vol 02.02.

<sup>2</sup> For referenced ASTM standards, visit the ASTM website, [www.astm.org](http://www.astm.org), or contact ASTM Customer Service at [service@astm.org](mailto:service@astm.org). For *Annual Book of ASTM Standards* volume information, refer to the standard's Document Summary page on the ASTM website.

## 5. Significance and Use

5.1 The DT energy value is a measure of resistance to rapid progressive fracturing. In a number of applications, the enhanced resistance that may develop during about one plate thickness of crack extension from a sharp notch is of major interest. In the test method, a sufficiently long fracture path is provided so that the results serve as a measure of this property.

5.2 Fracture surfaces of nonaustenitic steels tested in their temperature transition region have areas that appear bright and areas that appear dull. The bright, faceted appearing areas are termed “cleavage” fracture, and the dull appearing areas are termed “shear” fracture after their respective mode of fracture on a micro scale.

5.3 This test method can serve the following purposes:

5.3.1 In research and development, to evaluate the effects of metallurgical variables such as composition, processing, or heat treatment, or of fabricating operations such as forming and welding on the dynamic tear fracture resistance of new or existing materials.

5.3.2 In service evaluation, to establish the suitability of a material for a specific application only where a correlation between DT energy and service performance has been established.<sup>3</sup>

5.3.3 For information, specifications of acceptance, and manufacturing quality control when a minimum DT energy is requested. Detailed discussion of the basis for determining such minimum values in a particular case is beyond the scope of this test method.

## 6. Apparatus

6.1 *General Requirements*—The testing machine shall be either a pendulum type or a drop-weight type of capacity more than sufficient to break the specimen in one blow. DT energy values above 80 % of the initial potential energy of the blow are invalid. The capacity needed to conduct DT tests on most steels is 2000 ft-lbf (2700 J) for  $\frac{3}{8}$ -in. (16-mm) and 500 ft-lbf (700 J) for  $\frac{3}{16}$ -in. (5-mm) thick specimens. The capacity needed to conduct DT tests on the cast irons and aluminum alloys is less than 20 % of the values given above for most steels.

6.1.1 *Velocity Limitations*—Tests may be made at velocities that range from 13 to 28 ft/s (4.0 to 8.5 m/s). Velocity shall be stated as the velocity between the striker and the specimen at impact. This range in velocities corresponds to that of hammers dropped from heights of 32 in. to 12 ft (0.8 to 3.7 m).

6.1.2 The impact machine shall have a calibrated scale, charts, or direct reading-indicator of initial and final energy values, or the difference between the initial and final energy values. The scale, chart, or direct-reading indicator shall be divided so that DT energy values can be estimated within the following increments:

DT Energy Value	Maximum Increment
<40 ft-lbf (54 J)	2 ft-lbf (3 J)
40–600 ft-lbf (54–800 J)	5 % of DT energy
>600 ft-lbf (800 J)	30 ft-lbf (40 J)

6.1.2.1 The error in the DT energy value due to an error in the weight of the pendulum or the dropping weight, or due to an error in drop height, shall not exceed 1 %. Windage and friction may be compensated for by increasing the height of the drop, in which case the height may exceed the nominal value by not over 2.0 %.

6.1.3 The specimen anvil and the striker tip shall be of steel hardened to a minimum hardness value of 48 HRC and shall conform to the dimensions presented in Fig. 1. Clearance between the sides of the hammer and anvil shall not be less than 2.0 in. (51 mm), and the center line of the striker edge shall advance in the plane that is within 0.032 in. (0.80 mm) of the midpoint between the supporting edges of the specimen anvils. The striker edge shall be perpendicular to the longitudinal axis of the specimen within 0.01 rad. When in contact with the specimen, the striker edge shall be parallel within 0.005 rad to the face of a square test specimen held against the anvil. Specimen supports for pendulum machines shall be square with anvil faces within 0.0025 rad. Specimen supports shall be coplanar within 0.005 in. (0.125 mm) and parallel within 0.002 rad.

6.2 The design of the pendulum impact machines shall position the center of percussion at the center of strike within 1 % of the distance from the center of rotation to the center of the strike. When hanging free, the pendulums shall hang so that the striking edge is less than 0.20 in. (5.0 mm) from the edge position of the specimen.

6.2.1 The location of the center of percussion may be determined as follows: Using a stop watch or some other suitable timer to within 0.2 s, swing the pendulum through a total angle not greater than 15°, and record the time for 100 complete cycles (to and fro). Determine the center of percussion as follows:

$$l = 0.815\rho^2, \text{ to determine } l \text{ in feet} \quad (1)$$

$$l = 0.2485\rho^2, \text{ to determine } l \text{ in metres}$$

where:

$l$  = distance from the axis to the center of percussion, ft (or m), and

$\rho$  = time of a complete cycle (to and fro) of the pendulum, s.

6.2.2 For double-pendulum machines, the center of percussion of each pendulum shall be determined separately.

<sup>3</sup>Annual Book of ASTM Standards, Vol 03.01.

<sup>3</sup>Pellini, W. S., “Analytical Design Procedures for Metals of Elastic-Plastic and Plastic Fracture Properties,” *Welding Research Council Bulletin 186*, August 1973.

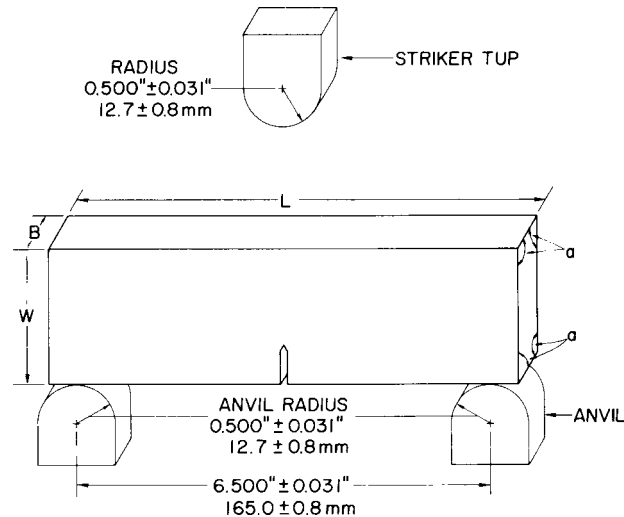

Dimensions and Tolerance for Specimen Blank

Parameter	Units	Dimension	Tolerance
Length, <i>L</i>	in.	7.125	±0.125
	mm	181	±3
Width, <i>W</i>	in.	1.60	±0.10
	mm	41	±2
Thickness, <i>B</i>	in.	0.625	±0.035
	mm	16	±1
Angularity, $\alpha$	deg	90	±1

NOTE 1—See 9.1 for specimens less than 5/8-in. (16 mm) thick.

FIG. 1 Dynamic Tear Test Specimen, Anvil Supports, and Striker

## 7. Safety Hazards

7.1 A safety screen shall surround the anvil to restrict the flight of broken specimens.

7.2 Precautions shall be taken to protect personnel from swinging pendulums, dropping weights, flying broken specimens, and hazards associated with specimen warming and cooling media.

## 8. Sampling

8.1 Notation of the orientation of base metal specimens shall be in accordance with that recommended in Test Method E 399.

8.2 If the thickness of the product is greater than 5/8 in. (16 mm), then a 5/8-in. (16-mm) thick specimen shall be the standard specimen.

## 9. Test Specimens

9.1 *Size of Specimens*—The specimen blank shall be *B* by 1.60 by 7.125 in. (*B* by 40.6 by 181.0 mm) where *B* can be from 3/16 to 5/8 in. (5 to 16 mm). The tolerances for these dimensions are presented in Fig. 1.

9.2 *Notch Detail*—The notch is machined to provide a fracture path in test material of 1.125 in. (28.5 mm); the small extension required for notch sharpening is considered a portion of the nominal net section. Details of the notch are shown in Fig. 2, and the notch dimensions shall conform to the values given therein.

### 9.3 Procedure for Preparing Notch:

9.3.1 *Rough Machining*—Machine a notch to the dimensions shown in Fig. 2. The angular apex portion and particularly the final cut on the root radius can be machined with a precisely ground saw, cutter, electric discharge machine, or any other machining process that will ensure a final root radius less than 0.005 in. (0.13 mm). These machining operations are normally performed simultaneously for a group of specimens.

9.3.2 *Pressing Notch Tip*—Pressing the sharp tip of the notch to the dimensions prescribed in Fig. 2 is performed on individual specimens. The impression is made with a blade of high-speed tool steel (60 HRC min), which has been ground to the dimensions presented in Fig. 3, and subsequently honed to remove any burrs or rough edges. Any loading device with sufficient capacity to press the knife to the prescribed depth may be used. The force required to accomplish the pressing is related to the hardness and the thickness of the specimen. The force required can be approximated by either of the following formulas:

$$\text{force (lbf)} = 47 \times \text{ultimate tensile strength (ksi)} \times B \text{ (in.)}$$

$$\text{force (N)} = 2.9 \times \text{ultimate tensile strength (MPa)} \times B \text{ (mm)}$$

MACHINING DIMENSIONS

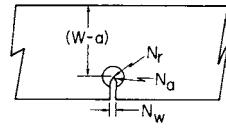

PRESSED TIP DETAILS

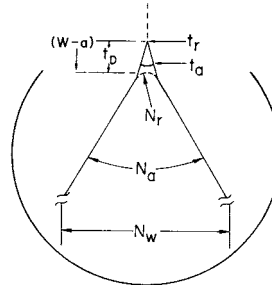

Dimensions and Tolerances for Notch Tip

Parameter	Units	Dimension	Tolerance
Net width, $(W - a)$	in.	1.125	$\pm 0.020$
	mm	28.6	$\pm 0.5$
Machined notch width, $N_w$	in.	0.0625	$\pm 0.005$
	mm	1.59	$\pm 0.13$
Machined notch root angle, $N_a$	deg	60	$\pm 2$
Machined notch root radius, $N_r$	in.	0.005	max
Pressed tip depth, $t_D$	mm	0.13	max
	in.	0.010	$\pm 0.005$
Pressed tip angle, $t_a$	mm	0.25	$\pm 0.13$
	deg	40	$\pm 5$
Pressed tip root radius, $t_r$	in.	0.001	max
	mm	0.025	max

FIG. 2 Details of the Notch in a Dynamic Tear Specimen

NOTCH SHARPENING KNIFE EDGE BLADE

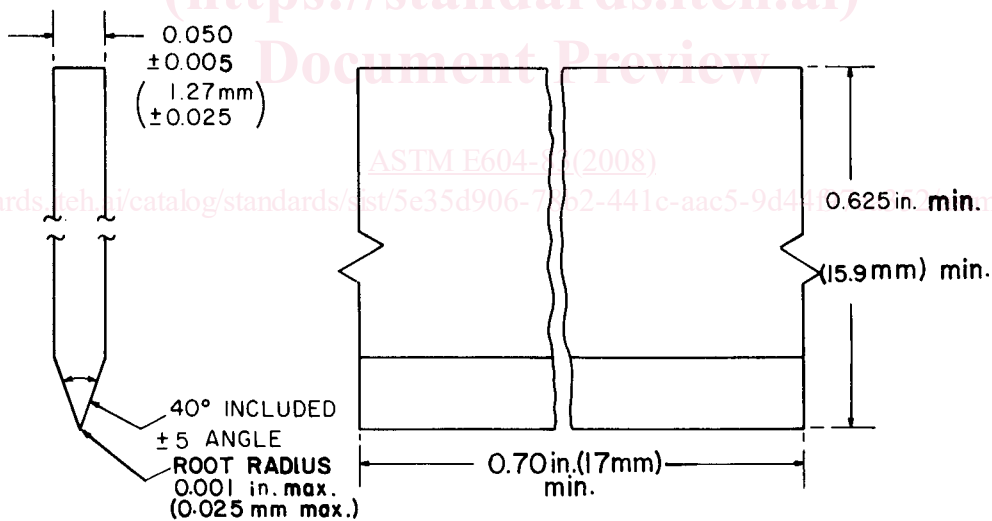

MATERIAL: TOOL STEEL (60 Rc)

FIG. 3 Knife for Sharpening Tip of Notch in Dynamic Tear Specimen

where  $B$  = thickness of the specimen.

NOTE 4—Suggested practices for measuring the pressed tip and for pressing the notch tip are given in the Appendixes.

10. Calibration of Apparatus

10.1 *Single-Pendulum Machine*—Support the pendulum horizontally ( $90 \pm 1^\circ$  from the rest position) at a point most convenient to react with a weighing device such as a platform scale, balance, or load cell, and determine the weight within 0.4 %. Take care to minimize friction at the bearing support and the weighing support. Measure the length of the moment arm (that is, the horizontal distance between the center of rotation and a vertical line that passes through the point of support) within 0.1 %. The potential energy at any angular position can be calculated from the following formula:

$$\text{Energy} = \text{weight} \times \text{moment arm} (1 - \cos \beta)$$

where  $\beta$  = the angle displaced when the pendulum is rotated from the position of rest when hanging free. An alternative procedure may be used if the distance between the center of rotation and the center of gravity is known within 0.1 %. The weight is then determined within 0.4 %, with the pendulum supported horizontally at a point in line with the center of gravity. The potential energy at any position is equal to the weight times the elevation of the center of gravity from the rest position.

10.1.1 The friction and windage loss of energy in the machine shall not exceed 2.0 % of the initial energy. The friction and windage loss is the difference between the potential energy of the pendulum from the starting position and the potential energy of the pendulum after it completes its swing without a specimen. Compensate the friction and windage loss so that zero energy is indicated when the pendulum is released without a specimen being present.

10.1.2 *Impact Velocity*—Determine the impact velocity,  $v$ , of the machine, neglecting friction as follows:

$$v = (2gh)^{1/2}$$

where:

- $g$  = acceleration of gravity,  $\text{ft/s}^2$  (or  $\text{m/s}^2$ ),
- $h$  = initial elevation of the striking edge, ft (or m), and
- $v$  = striking velocity, ft/s (or m/s).

10.2 *Double-Pendulum Machine*—The procedure for calibrating the hammer pendulum and the anvil pendulum shall be in accordance with the procedure in 10.1 for a single-pendulum machine. Calibrate the anvil pendulum without a specimen in place.

10.2.1 Determine and compensate the friction and windage loss of energy in accordance with the procedure described in 10.1.1.

10.3 *Vertical Drop-Weight Apparatus*— The dimensions of the apparatus shall be such that the falling hammer travels a minimum vertical distance of 2 in. (51 mm) after contacting the specimen before measurement is made of the final energy and 2.75 in. (70 mm) before an arresting device is activated, as shown in Fig. 4.

10.3.1 Calibration of an aluminum block system is required for each lot of blocks machined from a single bar. Segregate and mark for identification purposes blocks that have been prepared from each bar. The initial cross-sectional area of blocks from one lot shall not vary more than 0.2 %. Determine the average height of the blocks before and after test and record with an error not to exceed 0.0005 in. (0.013 mm). Develop a chart of absorbed energy versus deformation of blocks by conducting duplicate tests without a specimen at height increments not to exceed 1 ft (305 mm) through the calibrated range. Average the deformation values for the two blocks from each test; the average values for each height position shall agree within 0.003 in. (0.075 mm). Calculate the absorbed energy as the weight of the hammer times the height from the top surface of the aluminum blocks to the surface of the hammer that strikes the aluminum blocks. Construct a graph of absorbed energy versus the deformation of the aluminum blocks

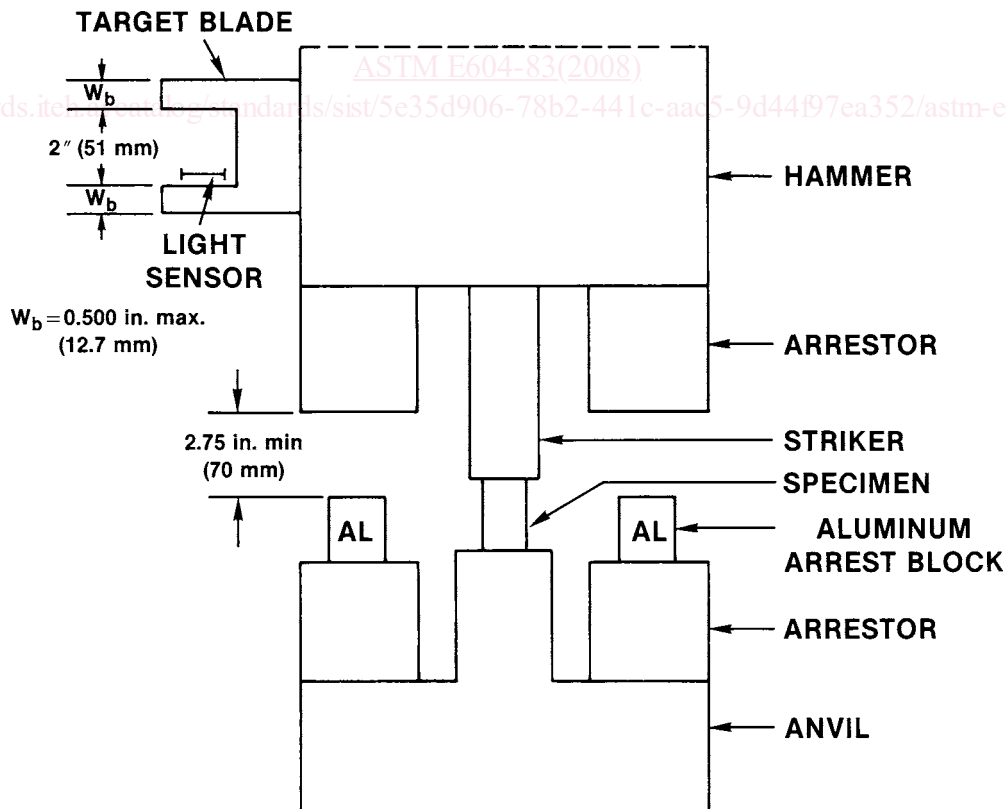

FIG. 4 Striker, Anvil, Aluminum Block Arrestors and Light Beam Velocity Sensor in a Vertical Drop-Weight Dynamic Tear Test Machine

as a smooth curve through the data points in the calibrated range. The dimensions of the aluminum blocks shall be such that the stiffness of a single block at any point in the calibrated range shall be as follows:

DT Energy Value	Stiffness per Block
50 ft-lbf (74 J) and under	1 ft-lbf/0.001 in. (54 J/mm)
greater than 50 ft-lbf (74 J)	2.5 ft-lbf/0.001 in. (136 J/mm)

This level of sensitivity permits the use of two aluminum blocks having an initial height of 1.5 in. (40 mm) and an initial diameter of 0.5 in. (13 mm) when less than 1000 ft lbf (1400 J) are absorbed by the two blocks. The material can be Specification B 221 alloy 1060, 1100, or 6061 in the O temper condition or after annealing at 775°F (413°C) and furnace cooling. Testing of DT specimens shall be conducted with the aluminum blocks at the same temperature used for calibration within 10°F (5.6°C).

10.3.2 The friction and windage loss shall not decrease the velocity of the strike by more than 1 % of the striking velocity as calculated in accordance with 10.1.2. Compensation for friction and windage loss can be made by adjusting the calibration curve of absorbed energy versus block deflection or by increasing the height of the drop to achieve the frictionless velocity as calculated in accordance with 10.1.2.

10.3.3 *Calibration of light-beam sensor velocity measurement device*—Dynamic tear energy can be obtained from measurements of hammer velocity before the strike and after the specimen has broken. The velocity is determined from a measurement of the time required for a target blade of known width to interrupt a narrow beam of light. The indicated or calculated velocity of the hammer over the calibrated range of the machine shall be equal to the velocity calculated in accordance with 10.1.2 within 1 %.

## 11. Procedure

11.1 In the temperature range from –100 to +212°F (–75 to 100°C), employ the procedure described in 11.1.1 and 11.1.2.

11.1.1 Completely immerse the specimens in a bath of suitable liquid at a temperature with  $\pm 2^\circ\text{F}$  ( $\pm 1^\circ\text{C}$ ) of the desired test temperature for a minimum of 15 min prior to testing. Separate the specimens by a distance at least equal to the thickness of the specimen. Support specimens placed horizontally in the bath on a screen or perforated platform at least 1 in. (25 mm) from the bottom. Make provision for circulation of the bath to assure uniform bath temperature.

NOTE 5—Alternatively, other methods of heating and cooling may be used, provided they produce equivalent time at temperature of the specimens.

11.1.2 Remove the specimens from the bath and break as described herein within a time period of 10 s. If the specimens are held out of the bath longer than 10 s, return them unbroken to the bath for a minimum of 10 min. Do not handle the specimens in the vicinity of the notch by devices whose temperature is appreciably different from the test temperature.

11.2 For temperatures outside of the range specified in 11.1, maintain the specimen temperature at the time of impact within  $\pm 2^\circ\text{F}$  ( $\pm 1^\circ\text{C}$ ) of the desired test temperature.

11.3 Place the specimen against the anvil supports so that the centerline of the striker is aligned within  $\pm 0.03$  in. ( $\pm 0.8$  mm) of the apex of the notch.

11.4 If any specimen jams in the machine, disregard the result and check the machine thoroughly for damage or maladjustments which would affect its calibration.

11.5 When requested, a fracture surface can be rated for “percent shear” by visually or instrumentally determining the relative amount of shear fracture present. The method used to determine percent shear should be agreed upon by the user and the producer. One method for determining percent shear fracture is in Appendix X3.

## 12. Report

12.1 A report shall include the material identification, test temperature, thickness of the specimen, and DT energy. When requested, the report shall also include, for base materials, the specimen orientation in the product, thickness of the product, heat number, and percent shear.

## 13. Precision and Bias

13.1 The precision and bias of the measurement obtained with this test method depend upon the material and the temperature of the test.<sup>4</sup>

# APPENDIXES

## (Nonmandatory Information)

### X1. MEASURING THE DEPTH OF THE PRESSED NOTCH TIP

#### X1.1 Introduction

X1.1.1 The depth of the pressed notch tip in a dynamic tear specimen is the reduction in the net width dimension that results

<sup>4</sup> See Pellini, W. S., “Analytical Design Procedures for Metals of Elastic-Plastic and Plastic Fracture Properties,” *Welding Research Council Bulletin 186*, August 1973.

<sup>4</sup> Supporting data have been filed at ASTM International Headquarters and may be obtained by requesting Research Report RR: E24-1000 and RR:E24-1007.