

SLOVENSKI STANDARD

SIST EN 4614:2021

01-december-2021

Nadomešča:

SIST EN 4614:2009

Aeronavtika - Kroglasti drsni ležaj iz korozijsko odpornega jekla s samomazalno oblogo, široki tip - Mere in nosilnosti - Palčne mere

Aerospace series - Spherical plain bearing in corrosion resisting steel with self-lubricating liner, wide series - Dimensions and loads - Inch series

Luft- und Raumfahrt - Gelenklager aus korrosionsbeständigem Stahl mit selbstschmierender Beschichtung, breite Reihe - Maße und Belastungen - Inch Reihe

Série aérospatiale - Rotules lisses résistant à la corrosion à garniture autolubrifiante, série large - Dimensions et charges - Series en inches

<https://standards.iteh.ai/catalog/standards/sist/36971d09-46ff-477e-930a-952ead4116c/sist-en-4614-2021>

Ta slovenski standard je istoveten z: EN 4614:2021

ICS:

49.035

Sestavni deli za letalsko in vesoljsko gradnjo

Components for aerospace construction

SIST EN 4614:2021

en,fr,de

iTeh STANDARD PREVIEW
(standards.iteh.ai)

SIST EN 4614:2021

<https://standards.iteh.ai/catalog/standards/sist/3b971d09-46ff-477e-930a-952eadf4116c/sist-en-4614-2021>

EUROPEAN STANDARD

EN 4614

NORME EUROPÉENNE

EUROPÄISCHE NORM

October 2021

ICS 49.035

Supersedes EN 4614:2009

English Version

Aerospace series - Spherical plain bearing in corrosion resisting steel with self-lubricating liner, wide series - Dimensions and loads - Inch series

Série aérospatiale - Rotule lisse, en acier résistant à la
corrosion, à garniture autolubrifiante, série large -
Dimensions et charges - Série en inches

Luft- und Raumfahrt - Gelenklager aus
korrosionsbeständigem Stahl mit selbstschmierender
Beschichtung, breite Reihe - Maße und Belastungen -
Inch Reihe

This European Standard was approved by CEN on 12 July 2020.

CEN members are bound to comply with the CEN/CENELEC Internal Regulations which stipulate the conditions for giving this European Standard the status of a national standard without any alteration. Up-to-date lists and bibliographical references concerning such national standards may be obtained on application to the CEN-CENELEC Management Centre or to any CEN member.

This European Standard exists in three official versions (English, French, German). A version in any other language made by translation under the responsibility of a CEN member into its own language and notified to the CEN-CENELEC Management Centre has the same status as the official versions.

CEN members are the national standards bodies of Austria, Belgium, Bulgaria, Croatia, Cyprus, Czech Republic, Denmark, Estonia, Finland, France, Germany, Greece, Hungary, Iceland, Ireland, Italy, Latvia, Lithuania, Luxembourg, Malta, Netherlands, Norway, Poland, Portugal, Republic of North Macedonia, Romania, Serbia, Slovakia, Slovenia, Spain, Sweden, Switzerland, Turkey and United Kingdom.



EUROPEAN COMMITTEE FOR STANDARDIZATION
COMITÉ EUROPÉEN DE NORMALISATION
EUROPÄISCHES KOMITEE FÜR NORMUNG

CEN-CENELEC Management Centre: Rue de la Science 23, B-1040 Brussels

Contents	Page
European foreword	3
1 Scope	4
2 Normative references	4
3 Terms, definitions and symbols	4
4 Requirements	5
4.1 Configuration, dimensions, tolerances and mass	5
4.2 Surface roughness	5
4.3 Material	5
4.4 Surface treatment	5
4.5 Loads and starting torque values	5
5 Designation	12
6 Marking	12
7 Technical specification	12
8 Quality management systems	13
Bibliography	14

iTech STANDARD PREVIEW
(standards.iteh.ai)

[SIST EN 4614:2021](https://standards.iteh.ai/catalog/standards/sist/3b971d09-46ff-477e-930a-952eadf4116c/sist-en-4614-2021)

<https://standards.iteh.ai/catalog/standards/sist/3b971d09-46ff-477e-930a-952eadf4116c/sist-en-4614-2021>

European foreword

This document (EN 4614:2021) has been prepared by the Aerospace and Defence Industries Association of Europe — Standardization (ASD-STAN).

After enquiries and votes carried out in accordance with the rules of this Association, this Standard has received the approval of the National Associations and the Official Services of the member countries of ASD-STAN, prior to its presentation to CEN.

This European Standard shall be given the status of a national standard, either by publication of an identical text or by endorsement, at the latest by April 2022, and conflicting national standards shall be withdrawn at the latest by April 2022.

Attention is drawn to the possibility that some of the elements of this document may be the subject of patent rights. CEN shall not be held responsible for identifying any or all such patent rights.

This document supersedes EN 4614:2009.

According to the CEN CENELEC Internal Regulations, the national standards organizations of the following countries are bound to implement this European Standard: Austria, Belgium, Bulgaria, Croatia, Cyprus, Czech Republic, Denmark, Estonia, Finland, France, Germany, Greece, Hungary, Iceland, Ireland, Italy, Latvia, Lithuania, Luxembourg, Malta, Netherlands, Norway, Poland, Portugal, Republic of North Macedonia, Romania, Serbia, Slovakia, Slovenia, Spain, Sweden, Switzerland, Turkey and the United Kingdom.

Any feedback and questions on this document should be directed to the users' national standards body. A complete listing of these bodies can be found on the CEN website.

<https://standards.iteh.ai/catalog/standards/sist/35971d09-401f-477e-930a-952eadf4116c/sist-en-4614-2021>

EN 4614:2021 (E)**1 Scope**

This document specifies the characteristics of a bearing, spherical plain in corrosion resisting steel with self-lubricating liner, wide series for aerospace applications.

These bearings are not intended for use of moving parts especially for control mechanism and operating system. They shall be used in the temperature range -55 °C to 163 °C .

2 Normative references

The following documents are referred to in the text in such a way that some or all of their content constitutes requirements of this document. For dated references, only the edition cited applies. For undated references, the latest edition of the referenced document (including any amendments) applies.

EN 2030, *Aerospace series — Steel X105CrMo17 (1.3544) — Hardened and tempered — Bars — $D_e \leq 150\text{ mm}$*

EN 2133, *Aerospace series — Cadmium plating of steels with specified tensile strength $\leq 1\,450\text{ MPa}$, copper, copper alloys and nickel alloys*

EN 2424, *Aerospace series — Marking of aerospace products*

EN 2755, *Aerospace series — Bearing, spherical plain in corrosion resisting steel with self-lubricating liner — Elevated load at ambient temperature — Technical specification*

EN 3161, *Aerospace series — Steel FE-PM3801 (X5CrNiCu17-4) — Air melted, solution treated and precipitation treated, bar a or $D \leq 200\text{ mm}$ — $R_m \geq 930\text{ MPa}$*

ISO 1132-1, *Rolling bearings — Tolerances — Part 1: Terms and definitions*
<https://standards.iteh.ai/catalog/standards/sist/3b971d09-46ff-477e-930a-952eadf4116c/sist-en-4614-2021>

ISO 8075, *Aerospace — Surface treatment of hardenable stainless steel parts*

TR 4475, *Bearings and mechanical transmissions for airframe applications — Vocabulary*¹

3 Terms, definitions and symbols

For the purposes of this document, the terms and definitions given in TR 4475 apply.

ISO and IEC maintain terminological databases for use in standardization at the following addresses:

- ISO Online browsing platform: available at <https://www.iso.org/obp>
- IEC Electropedia: available at <https://www.electropedia.org/>

Symbols of limit deviations are in accordance with definitions of ISO 1132-1.

α = maximum angle of tilt of the inner ring with respect to the outer ring, with the spherical raceway of the outer ring being completely in contact with the inner ring (see Figure 1 and Figure 2);

C_a = permissible static axial load;

C_s = permissible static radial load;

¹ Published as ASD STAN Technical Report at the date of publication of this standard by AeroSpace and Defence Industries Association of Europe – Standardization (ASD STAN) (www.asd-stan.org).

C_{25} = permissible dynamic radial load by 25 000 cycles;

Δd_{mp} = single plane mean bore diameter deviation;

ΔD_{mp} = single plane mean outside diameter deviation;

Δd_s = deviation of a single bore diameter;

ΔD_s = deviation of a single outside diameter.

4 Requirements

4.1 Configuration, dimensions, tolerances and mass

According to Figure 1, Figure 2 and Table 1. Dimensions and tolerances are expressed in millimetres (inches).

Values after passivating and/or cadmium plating.

4.2 Surface roughness

In accordance with Figure 1 and Figure 2. Values in micrometres (micro inches), apply prior to surface treatment.

4.3 Material

Inner ring: according to EN 2030, hardness $55 \leq \text{HRC} < 62$;

Outer ring: according to EN 3161, hardness $28 \leq \text{HRC} \leq 38$ before swaging;

Liner: self-lubricating liner according to EN 2755.

4.4 Surface treatment

Code T: Surface treatment according to ISO 8075 for inner ring before swaging.

Code P:

Without swaging groove code S: Surface treatment according to ISO 8075 for inner ring before swaging.

Cadmium plating of outer ring: $5 \mu\text{m}$ to $8 \mu\text{m}$ ($0.2 \mu\text{in}$ to $0.3 \mu\text{in}$) according to EN 2133 (cylindrical surface area and chamfers and both end surfaces at manufacturer's option), followed by chromating.

With swaging groove code R: Surface treatment according to ISO 8075 for inner ring before swaging.

Cadmium plating of outer ring: $5 \mu\text{m}$ to $8 \mu\text{m}$ ($0.2 \mu\text{in}$ to $0.3 \mu\text{in}$) according to EN 2133 (cylindrical surface area, broken angles and radii, respectively, as well as both end surfaces up to the swaging grooves), followed by chromating.

4.5 Loads and starting torque values

According to Table 2 and Table 3.

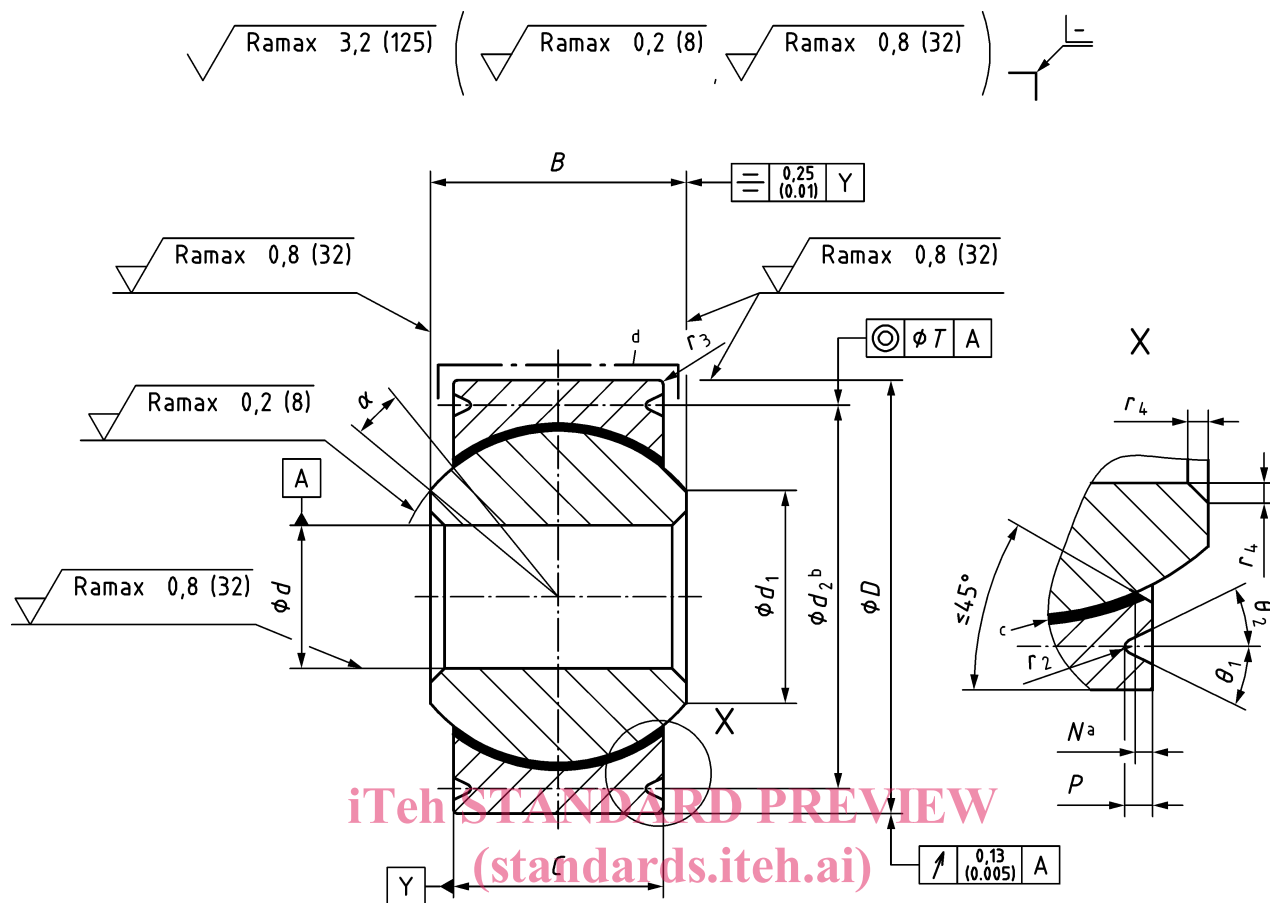

Key

- a set back
- b swaging groove
- c TFE liner
- d cadmium plated

SIST EN 4614:2021
<https://standards.itech.ai/catalog/standards/sist/3b971d09-46ff-477e-930a-952eadf4116c/sist-en-4614-2021>

Figure 1 — Code R — with swaging grooves

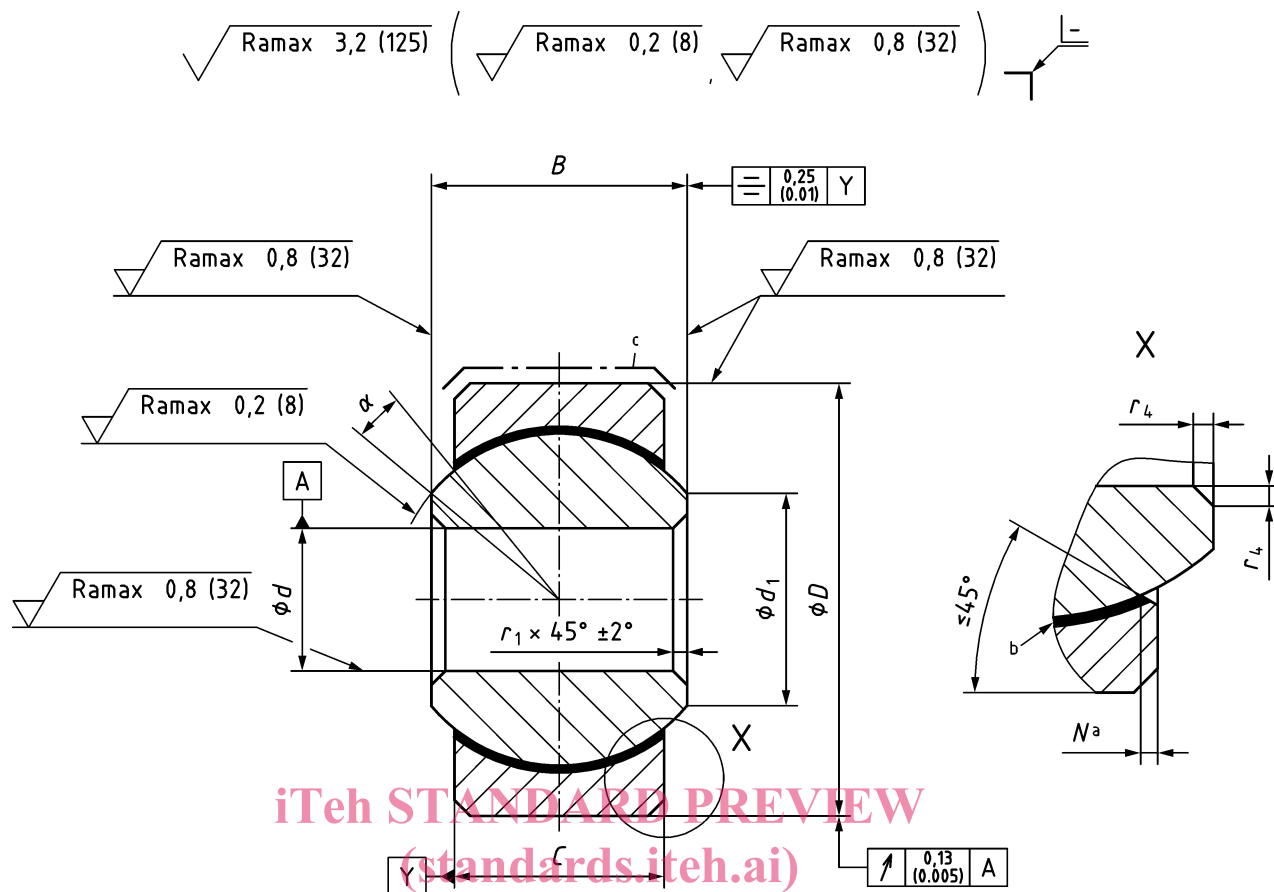

iTeh STANDARD PREVIEW
(standards.iteh.ai)

Key

- a set back
- b TFE liner
- c cadmium plated

SIST EN 4614:2021

<https://standards.iteh.ai/catalog/standards/sist/3b971d09-46ff-477e-930a-952eadf4116c/sist-en-4614-2021>

Figure 2 — Code S — without swaging grooves

Table 1 — Dimensions, tolerances and mass (1 of 2)

Dia- meter code ^a	Diameter		Limit deviation				<i>B</i>	<i>C</i>	<i>d</i> ₁	<i>d</i> ₂	<i>P</i>
	<i>d</i> mm (inches)	<i>D</i> mm (inches)	Δ_{dmp}	Δ_{ds}	Δ_{Dmp}	Δ_{Ds}	$\begin{matrix} 0 \\ -0,05 \\ \\ 0 \\ -0,002 \end{matrix}$	$\begin{matrix} \pm 0,13 \\ \\ (\pm 0,005) \end{matrix}$	min.	$\begin{matrix} 0 \\ -0,20 \\ \\ 0 \\ -0,008 \end{matrix}$	$\begin{matrix} 0 \\ -0,254 \\ \\ 0 \\ -0,010 \end{matrix}$
03	4,826 (0.190 0)	15,875						8,31	7,62	14,30	
04	6,350 (0.250 0)	(0.625 0)			$\begin{matrix} 0 \\ -0,008 \\ \\ 0 \\ -0,000 3 \end{matrix}$		11,10 (0.437)	(0.327)	(0.300)	(0.563)	0,635 (0.025 0)
05	7,937 (0.312 5)	17,462 (0.687 5)						8,05 (0.317)	9,14 (0.360)	15,87 (0.625)	
06	9,525 (0.375 0)	20,638 (0.812 5)					12,70 (0.500)	10,31 (0.406)	11,84 (0.466)	18,08 (0.712)	
07	11,113	23,812 (0.937 5)					14,28 (0.562)	11,23 (0.442)	13,64 (0.537)	21,26 (0.837)	
07A	(0.437 5)	23,017 (0.906 2)	$\begin{matrix} 0 \\ -0,013 \\ \\ 0 \\ -0,000 5 \end{matrix}$	$\begin{matrix} 0 \\ -0,009 \\ \\ 0 \\ -0,000 5 \end{matrix}$	$\begin{matrix} 0 \\ -0,013 \\ \\ 0 \\ -0,000 5 \end{matrix}$					20,52 (0.808)	0,889 (0.035 0)
08	12,700 (0.500 0)	25,400 (1.000 0)			$\begin{matrix} 0 \\ -0,004 \\ \\ 0 \\ -0,000 4 \end{matrix}$		15,88 (0.625)	12,83 (0.505)	15,42 (0.607)	22,86 (0.900)	
09	14,288 (0.562 5)	28,575 (1.125 0)	$\begin{matrix} 0 \\ -0,013 \\ \\ 0 \\ -0,000 5 \end{matrix}$				17,45 (0.687)	13,61 (0.536)	18,31 (0.721)	26,03 (1.025)	
10	15,875 (0.625 0)	30,163 (1.187 5)	$\begin{matrix} 0 \\ -0,000 5 \end{matrix}$				19,05 (0.750)	14,40 (0.567)	18,97 (0.747)	27,60 (1.087)	
12	19,050 (0.750 0)	34,925 (1.375 0)			$\begin{matrix} 0 \\ -0,011 \\ \\ 0 \\ -0,000 4 \end{matrix}$		22,23 (0.875)	16,00 (0.630)	21,46 (0.845)	31,78 (1.251)	
14	22,225 (0.875 0)	41,275 (1.625 0)						19,18 (0.755)	25,27 (0.995)	38,12 (1.501)	
16	25,400 (1.000 0)	53,975 (2.125 0)					34,93 (1.375)	25,53 (1.005)	32,23 (1.269)	50,82 (2.001)	
20	31,750 (1.250 0)	60,325 (2.375 0)					38,10 (1.500)	28,70 (1.130)	37,15 (1.463)	57,17 (2.251)	1,397 (0.055 0)
24	38,100 (1.500 0)	68,262 (2.687 5)	$\begin{matrix} +0,003 \\ -0,015 \\ \\ +0,000 1 \\ -0,000 6 \end{matrix}$	$\begin{matrix} 0 \\ -0,013 \\ \\ 0 \\ -0,000 5 \end{matrix}$	$\begin{matrix} +0,003 \\ -0,015 \\ \\ +0,000 1 \\ -0,000 6 \end{matrix}$		42,85 (1.687)	31,06 (1.223)	45,50 (1.791)	65,08 (2.562)	
28	44,450 (1.750 0)	76,200 (3.000 0)					46,02 (1.812)	33,45 (1.317)	49,90 (1.965)	73,05 (2.876)	
32	50,800 (2.000 0)	82,550 (3.250 0)					49,19 (1.937)	35,05 (1.380)	56,10 (2.209)	79,35 (3.124)	