

# SLOVENSKI STANDARD

## SIST EN 2880:2018

01-november-2018

---

**Aeronavtika - Zakovne matice, samozaporne, odporne proti gorivu, tesnjene, premične, dvostranske, z izvrtino za valjaste vijake, iz legiranega jekla, kadmiraane, mazane z MoS<sub>2</sub> - Klasifikacija: 900 MPa (pri okoljski temperaturi)/120 °C**

Aerospace series - Nuts, anchor, self-locking, fuel resistant, sealing, floating, two lug, with counterbore, in alloy steel, cadmium plated, MoS<sub>2</sub> lubricated - Classification: 900 MPa (at ambient temperature) / 120 °C

Luft- und Raumfahrt - Anniemuttern, selbstsichernd, druckdicht, kraftstoffbeständig, beweglich, beiderseitiger Flansch, mit zylindrischer Aussenkung, aus legiertem Stahl, verkadmet, MoS<sub>2</sub>-geschmiert - Klasse: 900 MPa (bei Raumtemperatur) / 120 °C

**iTeh STANDARD PREVIEW**

(standards.iteh.ai)

SIST EN 2880:2018

<https://standards.iteh.ai/catalog/standards/sist/f67a8572-7ef6-44e3-9863-4477c1000000/sist-en-2880-2018>

Série aérospatiale - Écrous à river, à freinage interne, étanches au carburant, flottants, double patte, avec chambrage, en acier allié, cadmiés, lubrifiés MoS<sub>2</sub> - Classification: 900 MPa (à température ambiante) / 120 °C

**Ta slovenski standard je istoveten z: EN 2880:2018**

---

**ICS:**

49.030.30 Matice

Nuts

**SIST EN 2880:2018**

**en,fr,de**

**iTeh STANDARD PREVIEW**  
**(standards.iteh.ai)**

SIST EN 2880:2018

<https://standards.iteh.ai/catalog/standards/sist/f67a8572-7ef6-44e3-9863-d437ce0f0cc1/sist-en-2880-2018>

EUROPEAN STANDARD

EN 2880

NORME EUROPÉENNE

EUROPÄISCHE NORM

September 2018

ICS 49.030.30

Supersedes

English Version

**Aerospace series - Nuts, anchor, self-locking, fuel resistant, sealing, floating, two lug, with counterbore, in alloy steel, cadmium plated, MoS2 lubricated - Classification: 900 MPa (at ambient temperature) / 120 °C**

Série aérospatiale - Écrous à river, à freinage interne, étanches au carburant, flottants, double patte, avec chambrage, en acier allié, cadmiés, lubrifiés MoS2 - Classification: 900 MPa (à température ambiante) / 120 °C

Luft- und Raumfahrt - Anniemuttern, selbstsichernd, druckdicht, kraftstoffbeständig, beweglich, beiderseitiger Flansch, mit zylindrischer Aussenkung, aus legiertem Stahl, verkadmet, MoS2-geschmiert - Klasse: 900 MPa (bei Raumtemperatur) / 120 °C

This European Standard was approved by CEN on 11 June 2018.

CEN members are bound to comply with the CEN/CENELEC Internal Regulations which stipulate the conditions for giving this European Standard the status of a national standard without any alteration. Up-to-date lists and bibliographical references concerning such national standards may be obtained on application to the CEN-CENELEC Management Centre or to any CEN member.

This European Standard exists in three official versions (English, French, German). A version in any other language made by translation under the responsibility of a CEN member into its own language and notified to the CEN-CENELEC Management Centre has the same status as the official versions.

CEN members are the national standards bodies of Austria, Belgium, Bulgaria, Croatia, Cyprus, Czech Republic, Denmark, Estonia, Finland, Former Yugoslav Republic of Macedonia, France, Germany, Greece, Hungary, Iceland, Ireland, Italy, Latvia, Lithuania, Luxembourg, Malta, Netherlands, Norway, Poland, Portugal, Romania, Serbia, Slovakia, Slovenia, Spain, Sweden, Switzerland, Turkey and United Kingdom.



EUROPEAN COMMITTEE FOR STANDARDIZATION  
COMITÉ EUROPÉEN DE NORMALISATION  
EUROPÄISCHES KOMITEE FÜR NORMUNG

**CEN-CENELEC Management Centre: Rue de la Science 23, B-1040 Brussels**

## Contents

	Page
European foreword.....	3
1 Scope.....	4
2 Normative references.....	4
3 Required characteristics .....	5
4 Designation.....	8
5 Marking.....	8
6 Technical specification.....	8

## iTeh STANDARD PREVIEW (standards.iteh.ai)

[SIST EN 2880:2018](https://standards.iteh.ai/catalog/standards/sist/f67a8572-7ef6-44e3-9863-d437ce0f0cc1/sist-en-2880-2018)

<https://standards.iteh.ai/catalog/standards/sist/f67a8572-7ef6-44e3-9863-d437ce0f0cc1/sist-en-2880-2018>

## European foreword

This document (EN 2880:2018) has been prepared by the Aerospace and Defence Industries Association of Europe - Standardization (ASD-STAN).

After enquiries and votes carried out in accordance with the rules of this Association, this Standard has received the approval of the National Associations and the Official Services of the member countries of ASD, prior to its presentation to CEN.

This European Standard shall be given the status of a national standard, either by publication of an identical text or by endorsement, at the latest by March 2019, and conflicting national standards shall be withdrawn at the latest by March 2019.

Attention is drawn to the possibility that some of the elements of this document may be the subject of patent rights. CEN shall not be held responsible for identifying any or all such patent rights.

This document supersedes EN 2880:1998.

According to the CEN-CENELEC Internal Regulations, the national standards organizations of the following countries are bound to implement this European Standard: Austria, Belgium, Bulgaria, Croatia, Cyprus, Czech Republic, Denmark, Estonia, Finland, Former Yugoslav Republic of Macedonia, France, Germany, Greece, Hungary, Iceland, Ireland, Italy, Latvia, Lithuania, Luxembourg, Malta, Netherlands, Norway, Poland, Portugal, Romania, Serbia, Slovakia, Slovenia, Spain, Sweden, Switzerland, Turkey and the United Kingdom.

[SIST EN 2880:2018](https://standards.iteh.ai/catalog/standards/sist/f67a8572-7ef6-44e3-9863-d437ce0f0cc1/sist-en-2880-2018)

<https://standards.iteh.ai/catalog/standards/sist/f67a8572-7ef6-44e3-9863-d437ce0f0cc1/sist-en-2880-2018>

**EN 2880:2018 (E)****1 Scope**

This European standard specifies the characteristics of self-locking, fuel resistant, sealing, floating, two lug anchor nuts, with counterbore, in alloy steel, cadmium plated, MoS<sub>2</sub> lubricated.

Classification: 900 MPa<sup>1)</sup>/120 °C<sup>2)</sup>.

**2 Normative references**

The following documents are referred to in the text in such a way that some or all of their content constitutes requirements of this document. For dated references, only the edition cited applies. For undated references, the latest edition of the referenced document (including any amendments) applies.

EN 2133, *Aerospace series — Cadmium plating of steels with specified tensile strength  $\leq 1\,450$  MPa, copper, copper alloys and nickel alloys*<sup>3)</sup>

EN 2424, *Aerospace series — Marking of aerospace products*

EN 2491, *Aerospace series — Molybdenum disulphide dry lubricants — Coating methods*

EN 9100, *Quality Management Systems — Requirements for Aviation, Space and Defence Organizations*

EN 9133, *Aerospace series — Quality Management Systems — Qualification Procedure for Aerospace Standard Products*

ISO 5855-2, *Aerospace — MJ threads - Part 2: Limit dimensions for bolts and nuts*

ISO 5858, *Aerospace — Nuts, self-locking, with maximum operating temperature less than or equal to 425 °C — Procurement specification*

ISO 8788, *Aerospace — Nuts, metric — Tolerances of form and position*

ISO 8940, *Aerospace — Nuts, anchor, self-locking, sealing, floating, two-lug, with counterbore, with MJ threads, classifications: 900 MPa (at ambient temperature)/120 °C, 900 MPa (at ambient temperature)/175 °C and 900 MPa (at ambient temperature)/235 °C — Dimensions*

MIL-R-6855E, *Rubber, Synthetic, Sheets, Strips, Molded or Extruded Shapes, General Specification for*<sup>4)</sup>

TR 3791, *Aerospace series — Materials for self-locking nuts, threaded inserts and screw thread inserts of temperature classes  $\leq 425$  °C*<sup>5)</sup>

---

1) Corresponds to the minimum tensile stress which the nut is able to withstand at ambient temperature without breaking or cracking when tested with a bolt of a higher strength class.

2) Maximum temperature that the nut is able to withstand, without permanent alteration to its original characteristics, after ambient temperature has been restored. The maximum temperature is conditioned by the sealing material.

3) Published as ASD-STAN Standard at the date of publication of this European standard ([www.asd-stan.org](http://www.asd-stan.org)).

4) Published by: Department of Defense (DoD), the Pentagon, Washington, D.C. 20301, USA.

5) Published as ASD-STAN Technical Report at the date of publication of this European standard ([www.asd-stan.org](http://www.asd-stan.org)).

### 3 Required characteristics

#### 3.1 Configuration – Dimensions – Masses

See Figure 1 and Table 1.

Dimensions and tolerances are: in conformity with ISO 8940, expressed in millimetres and apply after cadmium plating but before MoS<sub>2</sub> lubrication.

Details of form not stated are at the manufacturer's option.

#### 3.2 Tolerances of form and position

ISO 8788.

#### 3.3 Materials

Cage, seal retainer and nut element: TR 3791.

Sealing ring: rubber, fuel resistant per MIL-R-6855, class 1, grade 60 or equivalent.

#### 3.4 Surface treatments

Cage and seal retainer: EN 2133, 5 µm min. on all surfaces which can be contacted by a 20 mm diameter ball. On all other surfaces, a continuous deposit shall be present.

Nut element:

- EN 2133, 5 µm min. on all surfaces which can be contacted by a 20 mm diameter ball. On all other surfaces, a continuous deposit shall be present.
- EN 2491, thickness not specified, mandatory on threads, optional on other surfaces.

## EN 2880:2018 (E)

$$6,3 \sqrt{\left[ \frac{3,2}{\sqrt{\quad}} \right]} \quad 1)$$

Remove sharp edges 0,1 to 0,4.

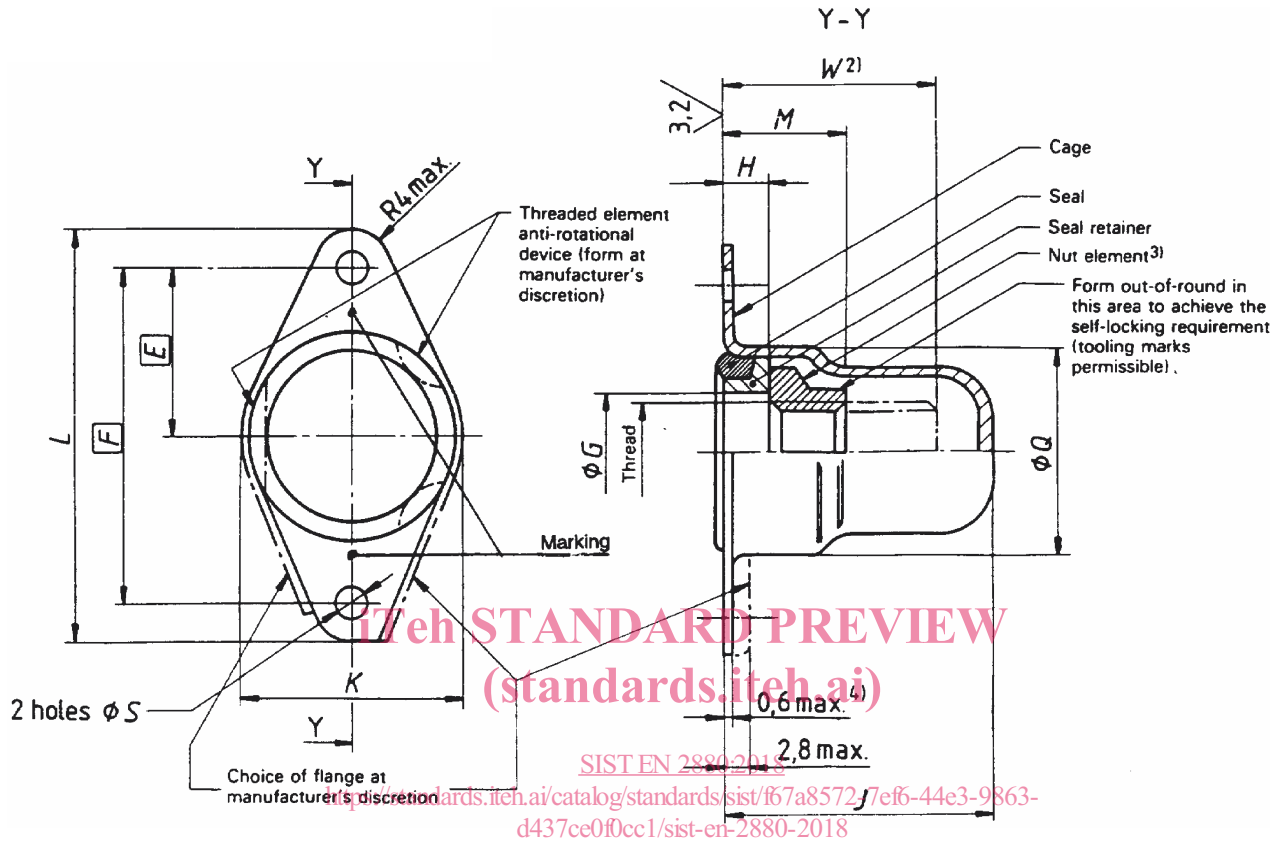

## Key

- 1) These values in micrometres apply before surface treatment. They do not apply to threads, punched holes or sheared edges the surface texture of which will be as achieved by usual manufacturing methods.
- 2) maximum bolt thread intrusion
- 3) minimum radial float of nut element: 0,5
- 4) lug thickness at the rivet location

Figure 1



Table 1

Diameter code	Thread <sup>a</sup>	<i>E</i>	<i>F</i>	<i>G</i> min.	<i>H</i> min	<i>J</i> max.	<i>K</i> max.	<i>L</i> max.	<i>M</i> max.	<i>O</i> max.	<i>S</i> +0,2 0	<i>W</i> max.	Mass <sup>b</sup>
050	MJ5×0,8 – 4H6H	9,5	19	6	3,4	16,2	14,4	24,6	7,9	12,5	2,5	14,4	4,3
060	MJ6×1 – 4H5H	11	22	7	4,1	19,2	17	29	9,5	16		17,4	7
080	MJ8×1 – 4H5H	13	26	9		4,1	20,3	19,4	32,5	11,3	18,5	3	18,5

<sup>a</sup> In accordance with ISO 5855-2. In the self-locking zone the tolerances apply before forming out-of-round.

<sup>b</sup> Approximate values (kg/1 000 pieces), given for information purposes only.

**iTeh STANDARD PREVIEW**  
(standards.iteh.ai)

SIST EN 2880:2018

<https://standards.iteh.ai/catalog/standards/sist/f67a8572-7ef6-44e3-9863-d437ce0f0cc1/sist-en-2880-2018>