

# DRAFT INTERNATIONAL STANDARD

## ISO/DIS 10512

ISO/TC 2/SC 12

Secretariat: DIN

Voting begins on:  
2016-03-31

Voting terminates on:  
2016-06-29

---

---

### Prevailing torque hexagon regular nuts (with non-metallic insert), with fine pitch thread — Product grades A and B

*Écrous hexagonaux normaux autofreinés (à anneau non métallique), à pas fin — Grades A et B*

ICS: 21.060.20

## iTeh STANDARD PREVIEW (standards.iteh.ai)

[ISO/DIS 10512](https://standards.iteh.ai/catalog/standards/sist/c8fb2d6b-94dd-476e-ad44-88110893a150/iso-dis-10512)

<https://standards.iteh.ai/catalog/standards/sist/c8fb2d6b-94dd-476e-ad44-88110893a150/iso-dis-10512>

THIS DOCUMENT IS A DRAFT CIRCULATED FOR COMMENT AND APPROVAL. IT IS THEREFORE SUBJECT TO CHANGE AND MAY NOT BE REFERRED TO AS AN INTERNATIONAL STANDARD UNTIL PUBLISHED AS SUCH.

IN ADDITION TO THEIR EVALUATION AS BEING ACCEPTABLE FOR INDUSTRIAL, TECHNOLOGICAL, COMMERCIAL AND USER PURPOSES, DRAFT INTERNATIONAL STANDARDS MAY ON OCCASION HAVE TO BE CONSIDERED IN THE LIGHT OF THEIR POTENTIAL TO BECOME STANDARDS TO WHICH REFERENCE MAY BE MADE IN NATIONAL REGULATIONS.

RECIPIENTS OF THIS DRAFT ARE INVITED TO SUBMIT, WITH THEIR COMMENTS, NOTIFICATION OF ANY RELEVANT PATENT RIGHTS OF WHICH THEY ARE AWARE AND TO PROVIDE SUPPORTING DOCUMENTATION.

#### ISO/CEN PARALLEL PROCESSING

This draft has been developed within the International Organization for Standardization (ISO), and processed under the **ISO lead** mode of collaboration as defined in the Vienna Agreement.

This draft is hereby submitted to the ISO member bodies and to the CEN member bodies for a parallel three month enquiry.

To expedite distribution, this document is circulated as received from the committee secretariat. ISO Central Secretariat work of editing and text composition will be undertaken at publication stage.



Reference number  
ISO/DIS 10512:2016(E)

© ISO 2016

**iTeh STANDARD PREVIEW**  
**(standards.iteh.ai)**

ISO/DIS 10512

<https://standards.iteh.ai/catalog/standards/sist/c8fb2d6b-94dd-476e-ad44-88110893a150/iso-dis-10512>



**COPYRIGHT PROTECTED DOCUMENT**

© ISO 2016, Published in Switzerland

All rights reserved. Unless otherwise specified, no part of this publication may be reproduced or utilized otherwise in any form or by any means, electronic or mechanical, including photocopying, or posting on the internet or an intranet, without prior written permission. Permission can be requested from either ISO at the address below or ISO's member body in the country of the requester.

ISO copyright office  
Ch. de Blandonnet 8 • CP 401  
CH-1214 Vernier, Geneva, Switzerland  
Tel. +41 22 749 01 11  
Fax +41 22 749 09 47  
copyright@iso.org  
www.iso.org

## Foreword

ISO (the International Organization for Standardization) is a worldwide federation of national standards bodies (ISO member bodies). The work of preparing International Standards is normally carried out through ISO technical committees. Each member body interested in a subject for which a technical committee has been established has the right to be represented on that committee. International organizations, governmental and non-governmental, in liaison with ISO, also take part in the work. ISO collaborates closely with the International Electrotechnical Commission (IEC) on all matters of electrotechnical standardization.

The procedures used to develop this document and those intended for its further maintenance are described in the ISO/IEC Directives, Part 1. In particular the different approval criteria needed for the different types of ISO documents should be noted. This document was drafted in accordance with the editorial rules of the ISO/IEC Directives, Part 2 (see [www.iso.org/directives](http://www.iso.org/directives)).

Attention is drawn to the possibility that some of the elements of this document may be the subject of patent rights. ISO shall not be held responsible for identifying any or all such patent rights. Details of any patent rights identified during the development of the document will be in the Introduction and/or on the ISO list of patent declarations received (see [www.iso.org/patents](http://www.iso.org/patents)).

Any trade name used in this document is information given for the convenience of users and does not constitute an endorsement.

For an explanation on the meaning of ISO specific terms and expressions related to conformity assessment, as well as information about ISO's adherence to the WTO principles in the Technical Barriers to Trade (TBT) see the following URL: Foreword - Supplementary information

The committee responsible for this document is ISO/TC 2, *Fasteners*, Subcommittee SC 12, *Fasteners with metric internal thread*.

This third edition cancels and replaces the second edition (ISO 10512:2012).

This standard differs from ISO 10512:2012 as follows:

- the Scope has been updated;
- threads M10x1,25 and M20x2 have been moved to the preferred threads table;
- dimension of thread M36 × 2 has been corrected to M36 × 3;
- the preferred and the non-preferred threads are given in two separate tables, and the threads M18×1,5, M22×1,5, M27×2, M33×2 and M39×3 have been added;
- for steel nuts, quenching and tempering have been specified in accordance with ISO 898-2 as mandatory or optional;
- the reference to ISO/TR 16224 for nut design has been added;
- stainless steel nuts have been added;
- "prevailing torque with non-metallic insert" has been replaced by the symbol "PTNM" in the designation.

# Prevailing torque hexagon regular nuts (with non-metallic insert), with fine pitch thread — Product grades A and B

## 1 Scope

This International Standard specifies the characteristics of prevailing torque hexagon regular nuts (with non-metallic insert) with fine pitch thread, with nominal diameters from 8 mm through 39 mm, with product grade A for nominal diameters  $D \leq 16$  mm and product grade B for nominal diameters  $D > 16$  mm.

NOTE The dimensions of the nuts correspond to those given in ISO 8673 plus prevailing torque feature.

## 2 Normative references

The following documents, in whole or in part, are normatively referenced in this document and are indispensable for its application. For dated references, only the edition cited applies. For undated references, the latest edition of the referenced document (including any amendments) applies.

ISO 225, *Fasteners — Bolts, screws, studs and nuts — Symbols and descriptions of dimensions*

ISO 262, *ISO general purpose metric screw threads — Selected sizes for screws, bolts and nuts* ISO 724, *ISO general-purpose metric screw threads — Basic dimensions*

ISO 724, *ISO general-purpose metric screw threads — Basic dimensions*

ISO 898-2, *Mechanical properties of fasteners made of carbon steel and alloy steel — Part 2: Nuts with specified property classes — Coarse thread and fine pitch thread*

ISO 965-2, *ISO general purpose metric screw threads — Tolerances — Part 2: Limits of sizes for general purpose external and internal screw threads — Medium quality*

ISO 2320, *Prevailing torque steel nuts — Functional properties*

ISO 3269, *Fasteners — Acceptance inspection*

ISO 3506-2, *Mechanical properties of corrosion-resistant stainless steel fasteners — Part 2: Nuts*

ISO 4042, *Fasteners — Electroplated coatings*

ISO 4759-1, *Tolerances for fasteners — Part 1: Bolts, screws, studs and nuts — Product grades A, B and C*

ISO 6157-2, *Fasteners — Surface discontinuities — Part 2: Nuts*

ISO 8992, *Fasteners — General requirements for bolts, screws, studs and nuts*

ISO 10683, *Fasteners — Non-electrolytically applied zinc flake coatings*

ISO 16048, *Passivation of corrosion-resistant stainless-steel fasteners*

### 3 Dimensions

See Figure 1 and Tables 1 and 2.

Symbols and descriptions of dimensions are specified in ISO 225.

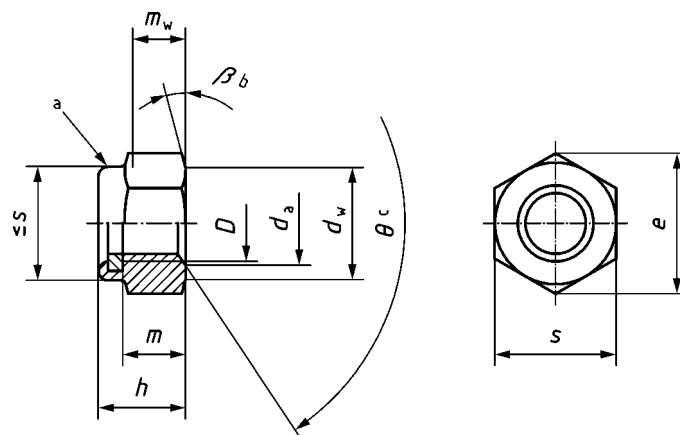

- a Prevailing torque element, shape at the discretion of the manufacturer.
- b  $\beta = 15^\circ$  to  $30^\circ$ .
- c  $\theta = 90^\circ$  to  $120^\circ$ .

**iTeh STANDARD PREVIEW**  
([standards.iteh.ai](https://standards.iteh.ai))

**Table 1 — Preferred threads**

<https://standards.iteh.ai/catalog/standards/sist/c8fb2d6b-94dd-476e-ad44-88110893a150/iso-dis-10512> Dimensions in millimetres

Thread, ( $D \times P^a$ )	M8×1	M10×1,25	M12×1,5	M16×1,5	M20×2	M24×2	M30×2	M36×3	
$d_a$	max.	8,75	10,80	13,00	17,30	21,60	25,90	32,40	38,90
	min.	8,00	10,00	12,00	16,00	20,00	24,00	30,00	36,00
$d_w$	min.	11,63	14,63	16,63	22,49	27,70	33,25	42,75	51,11
$e$	min.	14,38	17,77	20,03	26,75	32,95	39,55	50,85	60,79
$h$	max.	9,50	11,90	14,90	19,10	22,80	27,10	32,60	38,90
	min.	8,92	11,20	14,20	17,80	20,70	25,00	30,10	36,40
$m$	min.	6,44	8,04	10,37	14,10	16,90	20,20	24,30	29,40
$m_w$	min.	5,15	6,43	8,30	11,28	13,52	16,16	19,44	23,52
$s$	nom. = max.	13,00	16,00	18,00	24,00	30,00	36,00	46,00	55,00
	min.	12,73	15,73	17,73	23,67	29,16	35,00	45,00	53,80
<sup>a</sup> $P$ is the pitch of the thread.									

Table 2 — Non-preferred threads

Dimensions in millimetres

Thread, ( $D \times P^a$ )	M10×1	M12×1,25	M14×1,5	M18×2	M18×1,5	M20×1,5	M22×2	M22×1,5	M27×2	M33×2	M39×3	
$d_a$	max.	10,80	13,00	15,10	19,50	19,50	21,60	23,70	23,70	29,10	35,60	42,10
	min.	10,00	12,00	14,00	18,00	18,00	20,00	22,00	22,00	27,00	33,00	39,00
$d_w$	min.	14,63	16,63	19,64	24,85	24,85	27,70	31,35	31,35	38,00	46,55	55,86
$e$	min.	17,77	20,03	23,36	29,56	29,56	32,95	37,29	37,29	45,20	55,37	66,44
$h$	max.	11,90	14,90	17,00	21,00	21,00	22,80	25,00	25,00	29,00	35,80	42,00
	min.	11,20	14,20	15,90	19,70	19,70	20,70	22,90	22,90	27,80	33,30	39,50
$m$	min.	8,04	10,37	12,10	15,10	15,10	16,90	18,10	18,10	22,50	27,40	31,80
$m_w$	min.	6,43	8,30	9,68	12,08	12,08	13,52	14,48	14,48	18,00	21,92	25,44
$s$	nom. = max.	16,00	18,00	21,00	27,00	27,00	30,00	34,00	34,00	41,00	50,00	60,00
	min.	15,73	17,73	20,67	26,16	26,16	29,16	33,00	33,00	40,00	49,00	58,80
<sup>a</sup> $P$ is the pitch of the thread.												

## iTeh STANDARD PREVIEW (standards.iteh.ai)

ISO/DIS 10512

<https://standards.iteh.ai/catalog/standards/sist/c8fb2d6b-94dd-476e-ad44-88110893a150/iso-dis-10512>

## 4 Requirements and reference International Standards

See Table 3.

**Table 3 — Requirements and reference International Standards**

Material	Nut body	Steel		Stainless steel	
	Insert	e.g. polyamide			
<b>General requirements</b>	International Standard	ISO 8992			
<b>Thread</b>	Tolerance class	6H <sup>a</sup>			
	International Standards	ISO 262, ISO 724, ISO 965-2			
<b>Mechanical properties</b>	Property class	8 mm ≤ D ≤ 16 mm	6 <sup>b</sup> , 8 <sup>c</sup> , 10 <sup>c</sup>	8 mm ≤ D ≤ 24 mm	A2-70, A4-70, A4-80
		16 mm < D ≤ 39 mm	6 <sup>c</sup> , 8 <sup>c</sup> , 10 <sup>c</sup>	24 mm < D ≤ 39 mm	A2-50, A2-70, A4-70, A4-80
		D < 5 mm and D > 39 mm	Mechanical properties as agreed <sup>d</sup>	D < 5 mm and D > 39 mm	Mechanical properties as agreed
	International Standard	ISO 898-2	ISO 3506-2		
<b>Functional properties</b>	International Standard	ISO 2320	As agreed		
<b>Tolerance</b>	Product grade	D ≤ 16 mm: A D > 16 mm: B			
	International Standard	ISO 4759-1			
<b>Finish — Coating</b>	As processed Requirements for electroplating are specified in ISO 4042. Requirements for non-electrolytically applied zinc flake coatings are specified in ISO 10683. Additional requirements or other finishes or coatings shall be agreed between the supplier and the purchaser.			Clean and bright A method for passivation is specified in ISO 16048.	
<b>Surface integrity</b>	Limits for surface discontinuities are specified in ISO 6157-2.			—	
<b>Acceptability</b>	Acceptance inspection is specified in ISO 3269.				
<sup>a</sup> Other tolerance classes may be specified prior to coating, depending on the type of coating to be applied. For coated nuts, see relevant coating standards, e.g. ISO 4042 and ISO 10683. <sup>b</sup> May be quenched and tempered at the manufacturer's discretion, in accordance with ISO 898-2. <sup>c</sup> Shall be quenched and tempered in accordance with ISO 898-2. <sup>d</sup> See ISO/TR 16224 for information.					

## 5 Designation

EXAMPLE A Prevailing Torque (PT) hexagon regular nut with Non-Metallic insert (NM), with nominal diameter 12 mm, with fine pitch 1,5 mm and property class 8 is designated as follows:

**PTNM hexagon regular nut ISO 10512 - M12 × 1,5 - 8**

## Bibliography

ISO 8673, *Hexagon regular nuts (style 1) with metric fine pitch thread — Product grades A and B*

ISO/TR 16224, *Technical aspects of nut design*

**iTeh STANDARD PREVIEW**  
**(standards.iteh.ai)**

[ISO/DIS 10512](https://standards.iteh.ai/catalog/standards/sist/c8fb2d6b-94dd-476e-ad44-88110893a150/iso-dis-10512)

<https://standards.iteh.ai/catalog/standards/sist/c8fb2d6b-94dd-476e-ad44-88110893a150/iso-dis-10512>