

DRAFT INTERNATIONAL STANDARD

ISO/DIS 10511

ISO/TC 2/SC 12

Secretariat: DIN

Voting begins on:
2016-03-31

Voting terminates on:
2016-06-29

Prevailing torque hexagon thin nuts (with non-metallic insert) — Product grades A and B

Écrous hexagonaux bas autofreinés (à anneau non métallique) — Grades A et B

ICS: 21.060.20

iTeh STANDARD PREVIEW (standards.iteh.ai)

[ISO/DIS 10511](https://standards.iteh.ai/catalog/standards/sist/05d5996a-17d2-4fb0-904e-7b533b1dda15/iso-dis-10511)

<https://standards.iteh.ai/catalog/standards/sist/05d5996a-17d2-4fb0-904e-7b533b1dda15/iso-dis-10511>

THIS DOCUMENT IS A DRAFT CIRCULATED FOR COMMENT AND APPROVAL. IT IS THEREFORE SUBJECT TO CHANGE AND MAY NOT BE REFERRED TO AS AN INTERNATIONAL STANDARD UNTIL PUBLISHED AS SUCH.

IN ADDITION TO THEIR EVALUATION AS BEING ACCEPTABLE FOR INDUSTRIAL, TECHNOLOGICAL, COMMERCIAL AND USER PURPOSES, DRAFT INTERNATIONAL STANDARDS MAY ON OCCASION HAVE TO BE CONSIDERED IN THE LIGHT OF THEIR POTENTIAL TO BECOME STANDARDS TO WHICH REFERENCE MAY BE MADE IN NATIONAL REGULATIONS.

RECIPIENTS OF THIS DRAFT ARE INVITED TO SUBMIT, WITH THEIR COMMENTS, NOTIFICATION OF ANY RELEVANT PATENT RIGHTS OF WHICH THEY ARE AWARE AND TO PROVIDE SUPPORTING DOCUMENTATION.

ISO/CEN PARALLEL PROCESSING

This draft has been developed within the International Organization for Standardization (ISO), and processed under the **ISO lead** mode of collaboration as defined in the Vienna Agreement.

This draft is hereby submitted to the ISO member bodies and to the CEN member bodies for a parallel three month enquiry.

To expedite distribution, this document is circulated as received from the committee secretariat. ISO Central Secretariat work of editing and text composition will be undertaken at publication stage.



Reference number
ISO/DIS 10511:2016(E)

© ISO 2016

iTeh STANDARD PREVIEW
(standards.iteh.ai)

ISO/DIS 10511

<https://standards.iteh.ai/catalog/standards/sist/05d5996a-17d2-4fb0-904e-7b533b1dda15/iso-dis-10511>



COPYRIGHT PROTECTED DOCUMENT

© ISO 2016, Published in Switzerland

All rights reserved. Unless otherwise specified, no part of this publication may be reproduced or utilized otherwise in any form or by any means, electronic or mechanical, including photocopying, or posting on the internet or an intranet, without prior written permission. Permission can be requested from either ISO at the address below or ISO's member body in the country of the requester.

ISO copyright office
Ch. de Blandonnet 8 • CP 401
CH-1214 Vernier, Geneva, Switzerland
Tel. +41 22 749 01 11
Fax +41 22 749 09 47
copyright@iso.org
www.iso.org

Foreword

ISO (the International Organization for Standardization) is a worldwide federation of national standards bodies (ISO member bodies). The work of preparing International Standards is normally carried out through ISO technical committees. Each member body interested in a subject for which a technical committee has been established has the right to be represented on that committee. International organizations, governmental and non-governmental, in liaison with ISO, also take part in the work. ISO collaborates closely with the International Electrotechnical Commission (IEC) on all matters of electrotechnical standardization.

The procedures used to develop this document and those intended for its further maintenance are described in the ISO/IEC Directives, Part 1. In particular the different approval criteria needed for the different types of ISO documents should be noted. This document was drafted in accordance with the editorial rules of the ISO/IEC Directives, Part 2 (see www.iso.org/directives).

Attention is drawn to the possibility that some of the elements of this document may be the subject of patent rights. ISO shall not be held responsible for identifying any or all such patent rights. Details of any patent rights identified during the development of the document will be in the Introduction and/or on the ISO list of patent declarations received (see www.iso.org/patents).

Any trade name used in this document is information given for the convenience of users and does not constitute an endorsement.

For an explanation on the meaning of ISO specific terms and expressions related to conformity assessment, as well as information about ISO's adherence to the WTO principles in the Technical Barriers to Trade (TBT) see the following URL: Foreword - Supplementary information

The committee responsible for this document is ISO/TC 2, *Fasteners*, Subcommittee SC 12, *Fasteners with metric internal thread*.

This fourth edition cancels and replaces the third edition (ISO 10511:2012).

This standard differs from ISO 10511:2012 as follows:

- the Scope has been updated;
- a warning and a sentence have been added in the scope for the use of thin nuts;
- the chamfer angle has been improved from 90° to 120° to 110° to 120°;
- the preferred and the non-preferred threads are presented in two separate tables, and the threads M3,5, M7, M18, M22, M27, M33 and M39 have been added as non-preferred threads;
- $d_{w, \min}$ have been specified with two decimal place;
- for steel nuts, quenching and tempering is specified in accordance with ISO 898-2 as mandatory or optional;
- the reference to ISO/TR 16224 for nut design has been added;
- stainless-steel nuts have been added;
- "prevailing torque with non-metallic insert" has been replaced by the symbol "PTNM" in the designation.

Prevailing torque hexagon thin nuts (with non-metallic insert) — Product grades A and B

1 Scope

This International Standard specifies the characteristics of prevailing torque hexagon thin nuts (with non-metallic insert) with coarse pitch thread from nominal diameters M3 through M39, with product grade A for nominal diameters \leq M16 and product grade B for nominal diameters $>$ M16.

NOTE The dimensions of the nuts correspond to those given in ISO 4035 plus prevailing torque feature.

Thin nuts used as jam nuts shall be assembled together with a regular nut or a high nut.

WARNING Thin nuts (style 0) have a reduced loadability compared to regular nuts or high nuts, and are not designed to provide resistance to thread stripping (see ISO 898-2).

2 Normative references

The following documents, in whole or in part, are normatively referenced in this document and are indispensable for its application. For dated references, only the edition cited applies. For undated references, the latest edition of the referenced document (including any amendments) applies.

ISO 225, *Fasteners — Bolts, screws, studs and nuts — Symbols and descriptions of dimensions*

ISO 262, *ISO general purpose metric screw threads — Selected sizes for screws, bolts and nuts*

ISO 724, *ISO general-purpose metric screw threads — Basic dimensions*

ISO 898-2, *Mechanical properties of fasteners made of carbon steel and alloy steel — Part 2: Nuts with specified property classes — Coarse thread and fine pitch thread*

ISO 965-2, *ISO general purpose metric screw threads — Tolerances — Part 2: Limits of sizes for general purpose external and internal screw threads — Medium quality*

ISO 2320, *Prevailing torque type steel nuts — Mechanical and performance properties*

ISO 3269, *Fasteners — Acceptance inspection*

ISO 3506-2, *Mechanical properties of corrosion-resistant stainless steel fasteners — Part 2: Nuts*

ISO 4042, *Fasteners — Electroplated coatings*

ISO 4759-1, *Tolerances for fasteners — Part 1: Bolts, screws, studs and nuts — Product grades A, B and C*

ISO 6157-2, *Fasteners — Surface discontinuities — Part 2: Nuts*

ISO 8992, *Fasteners — General requirements for bolts, screws, studs and nuts*

ISO 10683, *Fasteners — Non-electrolytically applied zinc flake coatings*

ISO 16048, *Passivation of corrosion-resistant stainless-steel fasteners*

3 Dimensions

See Figure 1 and Tables 1 and 2.

Symbols and descriptions of dimensions are specified in ISO 225.

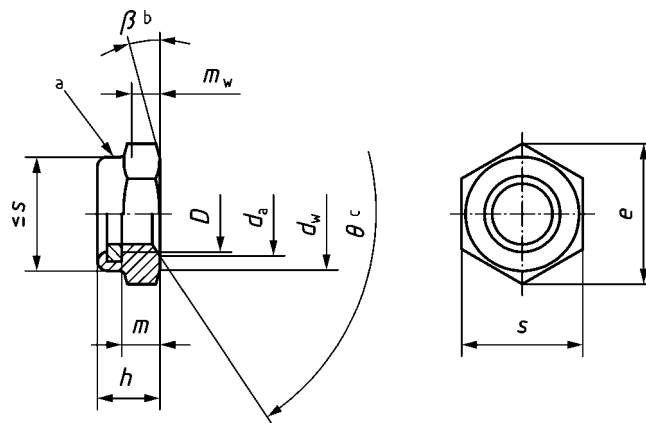

- a Prevailing torque element, shape at the discretion of the manufacturer.
- b $\beta = 15^\circ$ to 30° .
- c $\theta = 110^\circ$ to 120° .

Figure 1 — Dimensions
(standards.iteh.ai)

Table 1 — Preferred threads

ISO/DIS 10511

Dimensions in millimetres

Thread <i>D</i>	M3	M4	M5	M6	M8	M10	M12	M16	M20	M24	M30	M36	
<i>p</i> ^a	0,5	0,7	0,8	1	1,25	1,5	1,75	2	2,5	3	3,5	4	
<i>d_a</i>	max.	3,45	4,60	5,75	6,75	8,75	10,80	13,00	17,30	21,60	25,90	32,40	38,90
	min.	3,00	4,00	5,00	6,00	8,00	10,00	12,00	16,00	20,00	24,00	30,00	36,00
<i>d_w</i>	min.	4,57	5,88	6,88	8,88	11,63	14,63	16,63	22,49	27,70	33,25	42,75	51,11
<i>e</i>	min.	6,01	7,66	8,79	11,05	14,38	17,77	20,03	26,75	32,95	39,55	50,85	60,79
<i>h</i>	max.	3,90	5,00	5,00	6,00	6,76	8,56	10,23	12,42	14,90	17,80	22,20	25,50
	min.	3,42	4,52	4,52	5,52	6,18	7,98	9,53	11,32	13,10	16,00	20,10	23,40
<i>m</i>	min.	1,55	1,95	2,45	2,90	3,70	4,70	5,70	7,42	9,10	10,90	13,90	16,90
<i>m_w</i>	min.	1,24	1,56	1,96	2,32	2,96	3,76	4,56	5,94	7,28	8,72	11,12	13,52
<i>s</i>	max.	5,50	7,00	8,00	10,00	13,00	16,00	18,00	24,00	30,00	36,00	46,00	55,00
	min.	5,32	6,78	7,78	9,78	12,73	15,73	17,73	23,67	29,16	35,00	45,00	53,80
^a <i>P</i> is the pitch of the thread.													

Table 2 — Non-preferred threads

Dimensions in millimetres

Thread <i>D</i>		M3,5	M7	M14	M18	M22	M27	M33	M39
p^a		0,6	1	2	2,5	2,5	3	3,5	4
d_a	max.	4,00	7,75	15,10	19,50	23,70	29,10	35,60	42,10
	min.	3,50	7,00	14,00	18,00	22,00	27,00	33,00	39,00
d_w	min.	5,07	9,53	19,64	24,85	31,35	38,00	46,55	55,86
e	min.	6,58	12,01	23,36	29,56	37,29	45,20	55,37	66,44
h	max.	4,45	6,46	11,32	13,70	16,35	20,00	23,90	27,60
	min.	4,00	5,88	10,22	12,30	14,70	18,00	21,50	24,80
m	min.	1,75	3,34	6,42	8,42	9,90	12,40	15,40	18,20
m_w	min.	1,40	2,70	5,10	6,70	7,90	9,90	12,30	14,60
s	nom. = max.	6,00	11,00	21,00	27,00	34,00	41,00	50,00	60,00
	min.	5,82	10,63	20,67	26,16	33,00	40,00	49,00	58,80
^a P is the pitch of the thread.									

iTeh STANDARD PREVIEW
(standards.iteh.ai)

ISO/DIS 10511

<https://standards.iteh.ai/catalog/standards/sist/05d5996a-17d2-4fb0-904e-7b533b1dda15/iso-dis-10511>

4 Requirements and reference International Standards

See Table 3.

Table 3 — Requirements and reference International Standards

Material	Nut body	Steel	Stainless steel		
		Insert	e.g. polyamide		
General requirements	International Standard	ISO 8992			
Thread	Tolerance class	6H ^a			
	International Standards	ISO 262, ISO 724, ISO 965-2			
Mechanical properties	Property class	M5 < D ≤ M39	04 ^b , 05 ^c	M5 ≤ D ≤ M24	A2-035, A4-035, A4-040
				M24 < D ≤ M39	A2-025, A2-035, A4-035, A4-040
		D < M5 and D > M39	Mechanical properties as agreed ^d	D < M5 and D > M39	Mechanical properties as agreed
	International Standard	ISO 898-2	ISO 3506-2		
Functional properties	International Standard	ISO 2320	As agreed		
Tolerance	Product grade	D ≤ M16: A			
		D > M16: B			
	International Standard	ISO 4759-1			
Finish — Coating	As processed		Clean and bright		
	Requirements for electroplating are specified in ISO 4042. Requirements for non-electrolytically applied zinc flake coatings are specified in ISO 10683.		A method for passivation is specified in ISO 16048.		
Additional requirements or other finishes or coatings shall be agreed between the supplier and the purchaser.					
Surface integrity	Limits for surface discontinuities are specified in ISO 6157-2.		—		
Acceptability	Acceptance inspection is specified in ISO 3269.				
^a Other tolerance classes may be specified prior to coating, depending on the type of coating to be applied. For coated nuts, see relevant coating standards, e.g. ISO 4042 and ISO 10683. ^b May be quenched and tempered at the manufacturer's discretion, in accordance with ISO 898-2. ^c Shall be quenched and tempered in accordance with ISO 898-2. ^d See ISO/TR 16224 for information.					

5 Designation

EXAMPLE A Prevailing Torque (PT) hexagon thin nut, with Non-Metallic insert (NM), nominal diameter M12 and property class 04 is designated as follows:

PTNM hexagon thin nut ISO 10511 - M12 - 04

Bibliography

ISO 4035, *Hexagon thin nuts chamfered (style 0) — Product grades A and B*

ISO/TR 16224, *Technical aspects of nut design*

iTeh STANDARD PREVIEW
(standards.iteh.ai)

[ISO/DIS 10511](https://standards.iteh.ai/catalog/standards/sist/05d5996a-17d2-4fb0-904e-7b533b1dda15/iso-dis-10511)

<https://standards.iteh.ai/catalog/standards/sist/05d5996a-17d2-4fb0-904e-7b533b1dda15/iso-dis-10511>