



SLOVENSKI STANDARD
SIST ISO 1922:1996

01-januar-1996

Penjeni polimerni materiali - Trde pene - Določevanje strižne trdnosti

Cellular plastics -- Determination of shear strength of rigid materials

Plastiques alvéolaires -- Détermination de la résistance au cisaillement des matériaux rigides

(standards.iteh.ai)

Ta slovenski standard je istoveten z: ISO 1922:1981

<https://standards.iteh.ai/catalog/standards/sist/4af83981-710c-45ae-b0fb-e30053a7ef8/sist-iso-1922-1996>

ICS:

83.100

Penjeni polimeri

Cellular materials

SIST ISO 1922:1996

en

iTeh STANDARD PREVIEW
(standards.iteh.ai)

[SIST ISO 1922:1996](#)

<https://standards.iteh.ai/catalog/standards/sist/4af83981-710c-45ae-b0fb-e30053a7eff8/sist-iso-1922-1996>

International Standard



1922

INTERNATIONAL ORGANIZATION FOR STANDARDIZATION • МЕЖДУНАРОДНАЯ ОРГАНИЗАЦИЯ ПО СТАНДАРТИЗАЦИИ • ORGANISATION INTERNATIONALE DE NORMALISATION

Cellular plastics — Determination of shear strength of rigid materials

Plastiques alvéolaires — Détermination de la résistance au cisaillement des matériaux rigides

Second edition — 1981-11-01

Itch STANDARD PREVIEW
(standards.itech.ai)

[SIST ISO 1922:1996](https://standards.itech.ai/catalog/standards/sist/4af83981-710c-45ae-b0fb-e30053a7eff8/sist-iso-1922-1996)

<https://standards.itech.ai/catalog/standards/sist/4af83981-710c-45ae-b0fb-e30053a7eff8/sist-iso-1922-1996>

UDC 678-405.8 : 678.01 : 539.415

Ref. No. ISO 1922-1981 (E)

Descriptors : cellular materials, plastics, cellular plastics, tests, shear tests, shear strength, shear stress, test specimens, test results.

Foreword

ISO (the International Organization for Standardization) is a worldwide federation of national standards institutes (ISO member bodies). The work of developing International Standards is carried out through ISO technical committees. Every member body interested in a subject for which a technical committee has been set up has the right to be represented on that committee. International organizations, governmental and non-governmental, in liaison with ISO, also take part in the work.

Draft International Standards adopted by the technical committees are circulated to the member bodies for approval before their acceptance as International Standards by the ISO Council.

International Standard ISO 1922 was developed by Technical Committee ISO/TC 61, *Plastics*, and was circulated to the member bodies in April 1979.

It has been approved by the member bodies of the following countries:

Australia	Germany, F.R.	South Africa, Rep. of
Belgium	Hungary	Spain
Bulgaria	Israel	Sweden
Canada	Italy	Switzerland
China	Japan	Turkey
Cuba	Korea, Rep. of	United Kingdom
Czechoslovakia	Netherlands	USA
Egypt, Arab Rep. of	Poland	USSR
Finland	Romania	

The member bodies of the following countries expressed disapproval of the document on technical grounds:

France
India

This second edition cancels and replaces the first edition (i.e. ISO 1922-1972).

Cellular plastics — Determination of shear strength of rigid materials

1 Scope and field of application

This International Standard specifies a method of determining the shear strength of rigid cellular plastics. It also provides for the optional determination of shear modulus.

2 References

ISO 291, *Plastics — Standard atmospheres for conditioning and testing*.

ISO 1923, *Rigid cellular plastics — Determination of linear dimensions*.

3 Principle

Application of a shear stress to a test specimen of defined shape by means of metal supports bonded to the specimen.

4 Apparatus

4.1 Testing machine

The testing machine (see the figure) shall be such that:

- a test specimen having the form and dimensions specified in clause 5 is held vertically between two fixing devices each comprising a metal support, one of these devices being fixed and the other movable, and the stress being transmitted along the longitudinal axis of the test specimen;
- the movable grip can be moved away from the fixed grip at a constant rate of $1 \pm 0,5$ mm per minute in a direction parallel to the longitudinal axis of the test specimen;
- the force exerted on the test specimen can be known with a maximum error of 1 %, and the distance between the grips can be known with a maximum error of 0,01 mm, by means of recording devices.

4.2 Metal supports

These are metal supports, consisting of flat, rectangular-sectioned, mild steel plates, machined on one side, with a thickness of 16 ± 1 mm, and having the dimensions shown in the figure.

They shall be attached to the grips by the method shown in the figure.

The thickness of the adaptors that connect the metal supports to the testing machine grips shall be equal to the thickness of the test specimen.

4.3 Adhesive

The adhesive used to fix the metal supports to the test specimen shall be such that the shear strength and modulus of the adhesive film are significantly greater than that of the cellular material under test, so as to ensure ultimate failure in the cellular rather than at the adhesive interface. The adhesive shall also be compatible with the material under test. Details of a suitable adhesive and the method of application are given in the annex.

5 Test specimens

5.1 The test specimens shall be right parallelepipeds of the following dimensions:

- length: $250 \pm 0,5$ mm;
- width: $50 \pm 0,1$ mm;
- thickness: $25 \pm 0,5$ mm.

The distance between two parallel surfaces shall not vary by more than 1 %.

The dimensions shall be measured by the method specified in ISO 1923.

ISO 1922-1981 (E)

5.2 Test specimens shall be prepared without moulding skins. Their surfaces shall be machined without modifying the original structure.

The two machined surfaces of the metal supports shall be bonded to the larger surfaces of the dust-free test specimens so that the edges of the two metal supports are parallel to each other, as shown in the figure.

6 Number of test specimens

A set of five specimens shall be tested. When testing materials suspected of being anisotropic, sets of test specimens shall be prepared having major axes parallel with and normal to the suspected directions of anisotropy.

Test specimens that fail at the adhesive interface before failure of the cellular material shall be rejected and a greater number of test specimens shall be used so that the number of significant results is not less than five.

7 Conditioning and test temperature

Test specimens shall be conditioned immediately before testing for a period of not less than 16 h at a temperature of 23 ± 2 °C and at 50 ± 5 % relative humidity, in accordance with ISO 291.

The test shall be conducted at a temperature of 23 ± 2 °C.

8 Procedure

Attach the test specimen to the grips of the testing machine and apply a force by separating the movable grip from the fixed grip at a rate of $1 \pm 0,5$ mm per minute, with a variation not greater than 10 % during the test.

Record the force-deflection diagram.

NOTE — The following procedure is suggested to correct for the force imposed on the sample by the metal supports and attachments.

Before attaching the test assembly to the machine attachments the testing machine shall be adjusted to null force.

If the force measuring device is in the upper position, correct for the force imposed by one metal support and attachments by subtracting their predetermined weight from the recorded force.

If the force measuring device is in the lower position, correct for the force imposed by one metal support and attachments by adding their predetermined weight to the recorded force.

9 Calculation and expression of results

9.1 Shear strength

The shear strength, q , of the specimen, expressed in kilopascals, is given by the formula

$$\frac{1\,000 \times F_m}{l \times b}$$

where

l is the initial length, in millimetres, of the test specimen;

b is the initial width, in millimetres, of the test specimen;

F_m is the maximum force, in newtons, applied to the test specimen.

9.2 Shear modulus

If desired, calculate the shear modulus, G , of the specimen, in kilopascals, using the formula

$$\frac{1\,000 \times \delta \times \theta}{l \times b}$$

where

δ is the thickness, in millimetres, of the test specimen;

θ is the slope of the linear portion of the force-deflection diagram, expressed in newtons per millimetre;

l is the initial length, in millimetres, of the test specimen;

b is the initial width, in millimetres, of the test specimen.

10 Test report

The test report shall include the following particulars:

- reference to this International Standard;
- complete identification of the material tested;
- where applicable, the direction of application of the force with respect to any anisotropy;
- the individual shear strength test results and the average shear strength for each direction of test;
- if calculated, the individual shear modulus values and the average shear modulus values for each direction of test;
- the mode of failure;
- any deviation from the method specified, any operational details not specified in this International Standard, and any circumstances liable to have had an influence upon the results.

Annex

Choice of adhesives for preparation of test specimens

Experience has indicated that the conformity of thickness and to a lesser extent the amount of adhesive used, are critical. Sufficient time for the adhesive to cure shall be allowed, the test specimens being undisturbed during that period. The curing period may constitute part or the whole of the conditioning period.

It has been found that satisfactory results for most materials can be obtained using an epoxy-based adhesive applied to a uniform thickness.

It has been found that satisfactory results for some materials can be obtained by:

- a) using a low-viscosity unsaturated-polyester adhesive which may be applied by means of a small brush (for example a 25 mm paint brush);
- b) coating the surfaces to be bonded with the adhesive (the use of 5 g of adhesive for each surface is suggested);
- c) ensuring that the adhesive is applied within 15 min of mixing at 23 ± 2 °C;
- d) allowing at least 16 h for the adhesive to cure.

iTeh STANDARD PREVIEW
(standards.iteh.ai)

[SIST ISO 1922:1996](https://standards.iteh.ai/catalog/standards/sist/4af83981-710c-45ae-b0fb-e30053a7eff8/sist-iso-1922-1996)

<https://standards.iteh.ai/catalog/standards/sist/4af83981-710c-45ae-b0fb-e30053a7eff8/sist-iso-1922-1996>

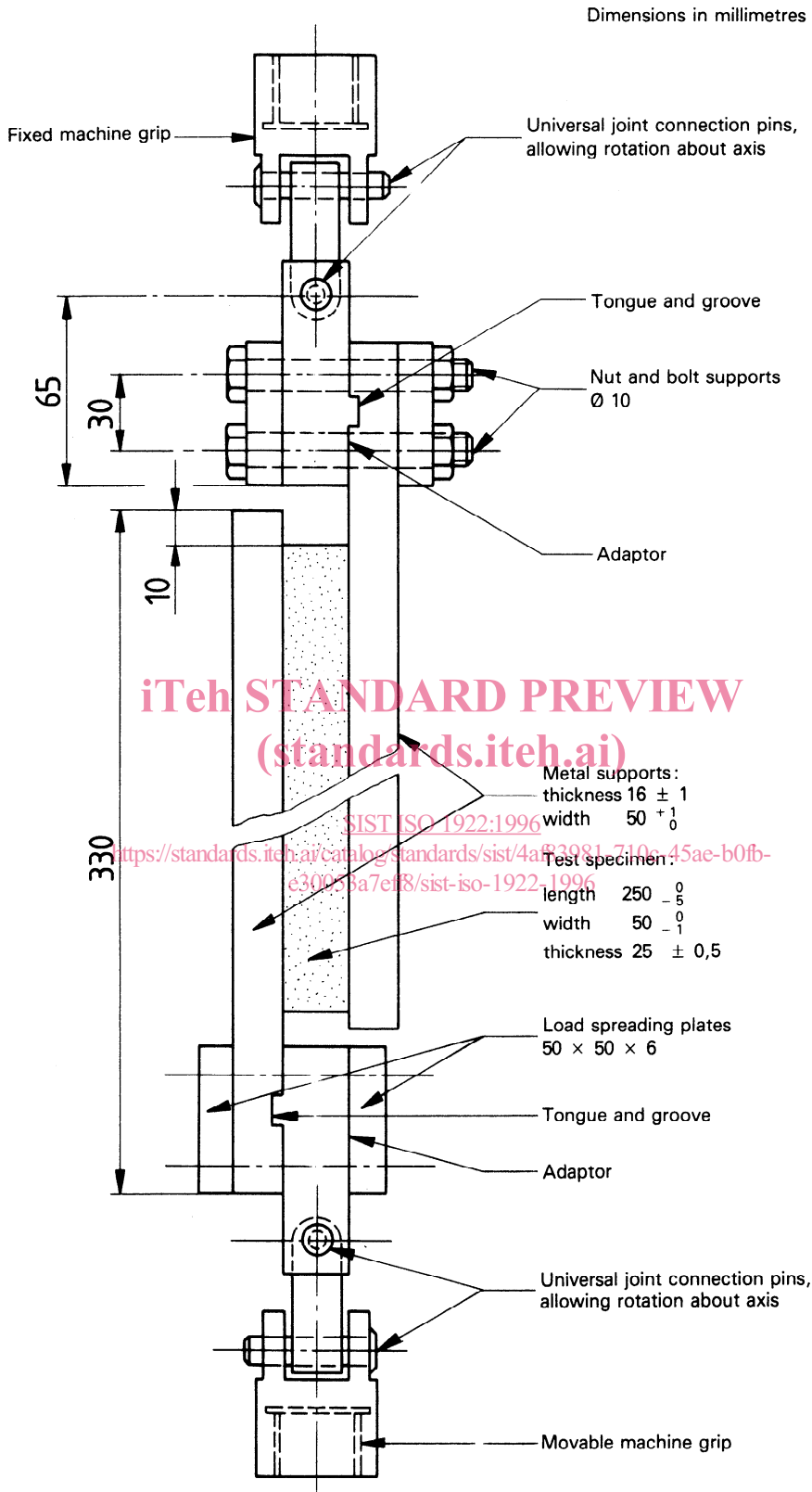

Figure — Test assembly