



Designation: ~~C1306-05a~~ Designation: C 1306 – 08

Standard Test Method for Hydrostatic Pressure Resistance of a Liquid-Applied Waterproofing Membrane¹

This standard is issued under the fixed designation C 1306; the number immediately following the designation indicates the year of original adoption or, in the case of revision, the year of last revision. A number in parentheses indicates the year of last reapproval. A superscript epsilon (ϵ) indicates an editorial change since the last revision or reapproval.

1. Scope

1.1 This test method describes a laboratory procedure for determining the resistance of a waterproofing membrane to hydrostatic pressure.

~~1.2 The values stated in SI units are to be regarded as the standard. The inch-pound units given in parentheses are for information only.~~

~~1.3 The committee with jurisdiction over this standard is not aware of any comparable standards published by other organizations.~~

~~1.4~~

1.2 The committee with jurisdiction over this standard is not aware of any comparable standards published by other organizations.

1.3 There are no ISO standards similar or equivalent to this ASTM standard.

1.4 The values stated in SI units are to be regarded as standard. The values given in parentheses are mathematical conversions to inch-pound units that are provided for information only and are not considered standard.

1.5 This standard does not purport to address all of the safety concerns, if any, associated with its use. It is the responsibility of the user of this standard to establish appropriate safety and health practices and determine the applicability of regulatory limitations prior to use.

~~1.5 There are no ISO standards similar or equivalent to this ASTM standard.~~

2. Referenced Documents

2.1 ~~ASTM Standards:~~

~~C 33 Specification for Concrete Aggregates~~

~~C 150 Specification for Portland Cement~~ ASTM Standards:²

C 717 Terminology of Building Seals and Sealants Terminology of Building Seals and Sealants

C 1375 Guide for Substrates Used in Testing Building Seals and Sealants b-88a2-745830c756c4/astm-c1306-08

3. Terminology

3.1 ~~Definitions~~—Refer to Terminology C 717 for definitions of technical terms used in this test ~~standard~~ method.

4. Summary of Test Method

4.1 This test method is conducted in two stages. In the first stage, the test membrane is subjected to hydrostatic pressure that is increased steadily over an 8 h period until the specimen fails or the maximum pressure is achieved. In the second part of the test, three more specimens are subjected to hydrostatic pressure that is increased slowly from 50 % of the failure value to failure in 2.5 psi increments every two to three days.

5. Significance and Use

5.1 This test method is used as a screening tool to determine the hydrostatic pressure to which a liquid-applied waterproofing membrane may be subjected without failing when stretched over a crack in the substrate. This test method discriminates between a membrane that is very resistant to hydrostatic pressure and one that is not. Because of the variability inherent in this test method,

¹ This test method is under the jurisdiction of ASTM Committee D08 on Roofing and Waterproofing and is the direct responsibility of Subcommittee D08.22 on Waterproofing and Dampproofing Systems.

Current edition approved Sept. 1, 2005. Published October 2005. Originally approved in 1995. Last previous edition approved in 2005 as C 1306-05.

Current edition approved Dec. 15, 2008. Published January 2009. Originally approved in 1995. Last previous edition approved in 2005 as C 1306-05a.

² For referenced ASTM standards, visit the ASTM website, www.astm.org, or contact ASTM Customer Service at service@astm.org. For *Annual Book of ASTM Standards* volume information, refer to the standard's Document Summary page on the ASTM website.

it is not recommended that this test method be used to set a numerical standard for hydrostatic pressure resistance. No prediction of durability at lower hydrostatic pressures can be made when using the results of this test method.

6. Comparison to Other Standards

6.1 The committee with jurisdiction over this standard is not aware of any comparable standards published by other organizations.

7. Apparatus and Materials

- 7.1 *Test Apparatus*, made of Schedule 80 PVC pipe pieces and constructed as shown in Fig. 1.
- 7.2 *Masking Tape*.
- 7.3 *TFE-Fluorocarbon or Polyethylene Spacers*, three, 51 by 19 by 3 mm (2 by 0.75 by 0.125 in.).
- 7.4 *Circulating Hot-Air Oven*.
- 7.5 *Portland Cement*, high early strength, conforming to Specification C150, Type III.
- 7.6 *Fine Aggregate*, conforming to Specification C33.
- 7.7 *Source of Regulated Compressed Air*, capable of at least 45 psig.
- 7.8 *Molds*, eight, 102 by 50 by 13 mm (4 by 2 by 0.5 in.) inside dimensions, for casting mortar blocks.
- 7.9
- 7.6 *Epoxy Cement*, with gap filling capability, or non-sag construction mastic.
- 7.10
- 7.7 *Sealing Gaskets*, eight, 102 mm (4 in.) outside diameter by 57 mm (2.25 in.) inside diameter by 6 mm (0.25 in.) thick made of very soft rubber.³
- 7.11
- 7.8 *Vernier Calipers*.

³ Adco SP 505 and Ashland Plioseal T408 rubber sealing tapes have been found suitable for this purpose.
³ The sole sources of supply of the materials (ADCO SP 505 and Ashland Plioseal T408 rubber sealing tapes) known to the committee at this time is ADCO Products, 100 Tri State International, Suite 135, Lincolnshire, IL 60069 and Ashland Inc., 50 E. RiverCenter Blvd., P.O. Box 391, Covington, KY 41012-0391. If you are aware of alternative suppliers, please provide this information to ASTM International Headquarters. Your comments will receive careful consideration at a meeting of the responsible technical committee, which you may attend.

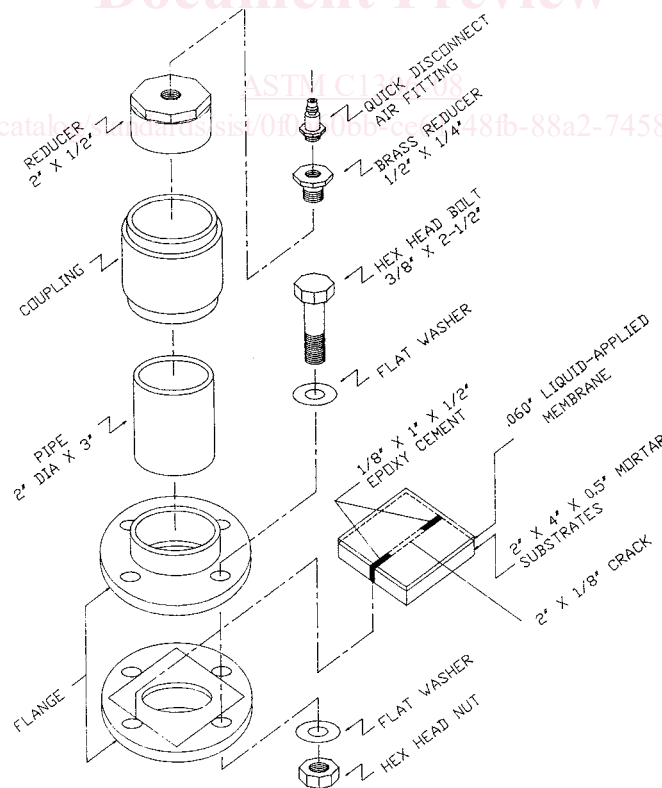

NOTE 1—All parts made of schedule 80 PVC.

FIG. 1 Testing Apparatus